

FLSTDmSCHE

Software for the management of chiller screw

Code: FLSTDmSCHE

CAREL



ENG User manual

**LEGGI E CONSERVA
QUESTE ISTRUZIONI**
**READ AND SAVE
THESE INSTRUCTIONS**

**NO POWER
& SIGNAL
CABLES
TOGETHER**
READ CAREFULLY IN THE TEXT!

High Efficiency Solutions

IMPORTANT



CAREL bases the development of its products on decades of experience in HVAC/R, on the continuous investments in technological innovations to products, procedures and strict quality processes with in-circuit and functional testing on 100% of its products, and on the most innovative production technology available on the market. CAREL and its subsidiaries nonetheless cannot guarantee that all the aspects of the product and the software included with the product respond to the requirements of the final application, despite the product being developed according to start-of-the-art techniques. The customer (manufacturer, developer or installer of the final equipment) accepts all liability and risk relating to the configuration of the product in order to reach the expected results in relation to the specific final installation and/or equipment.

CAREL may, based on specific agreements, acts as a consultant for the positive commissioning of the final unit/application, however in no case does it accept liability for the correct operation of the final equipment/system.

The CAREL product is a state-of-the-art product, whose operation is specified in the technical documentation supplied with the product or can be downloaded, even prior to purchase, from the website www.CAREL.com.

Each CAREL product, in relation to its advanced level of technology, requires setup/configuration/programming/commissioning to be able to operate in the best possible way for the specific application. The failure to complete such operations, which are required/indicated in the user manual, may cause the final product to malfunction; CAREL accepts no liability in such cases.

Only qualified personnel may install or carry out technical service on the product.

The customer must only use the product in the manner described in the documentation relating to the product.

In addition to observing any further warnings described in this manual, the following warnings must be heeded for all CAREL products:

- Prevent the electronic circuits from getting wet. Rain, humidity and all types of liquids or condensate contain corrosive minerals that may damage the electronic circuits. In any case, the product should be used or stored in environments that comply with the temperature and humidity limits specified in the manual.
- Do not install the device in particularly hot environments. Too high temperatures may reduce the life of electronic devices, damage them and deform or melt the plastic parts. In any case, the product should be used or stored in environments that comply with the temperature and humidity limits specified in the manual.
- Do not attempt to open the device in any way other than described in the manual.
- Do not drop, hit or shake the device, as the internal circuits and mechanisms may be irreparably damaged.
- Do not use corrosive chemicals, solvents or aggressive detergents to clean the device.
- Do not use the product for applications other than those specified in the technical manual.

All of the above suggestions likewise apply to the controllers, serial boards, programming keys or any other accessory in the CAREL product portfolio.

CAREL adopts a policy of continual development. Consequently, CAREL reserves the right to make changes and improvements to any product described in this document without prior warning.

The technical specifications shown in the manual may be changed without prior warning.

The liability of CAREL in relation to its products is specified in the CAREL general contract conditions, available on the website www.CAREL.com and/or by specific agreements with customers;

specifically, to the extent where allowed by applicable legislation, in no case will CAREL, its employees or subsidiaries be liable for any lost earnings or sales, losses of data and information, costs of replacement goods or services, damage to things or people, downtime or any direct, indirect, incidental, actual, punitive, exemplary, special or consequential damage of any kind whatsoever, whether contractual, extra-contractual or due to negligence, or any other liabilities deriving from the installation, use or impossibility to use the product, even if CAREL or its subsidiaries are warned of the possibility of such damage.



INFORMATION FOR USERS ON THE CORRECT HANDLING OF WASTE ELECTRICAL AND ELECTRONIC EQUIPMENT (WEEE)

In reference to European Union directive 2002/96/EC issued on 27 January 2003 and the related national legislation, please note that:

- WEEE cannot be disposed of as municipal waste and such waste must be collected and disposed of separately;
- the public or private waste collection systems defined by local legislation must be used. In addition, the equipment can be returned to the distributor at the end of its working life when buying new equipment;
- the equipment may contain hazardous substances: the improper use or incorrect disposal of such may have negative effects on human health and on the environment;
- the symbol (crossed-out wheeled bin) shown on the product or on the packaging and on the instruction sheet indicates that the equipment has been introduced onto the market after 13 August 2005 and that it must be disposed of separately;
- in the event of illegal disposal of electrical and electronic waste, the penalties are specified by local waste disposal legislation.

Warranty of the materials: 2 years (from the date of production, excluding consumables).

Approval: the quality and safety of CAREL INDUSTRIES Hqs products are guaranteed by the ISO 9001 certified design and production system.



WARNING: separate as much as possible the probe and digital input signal cables from the cables carrying inductive loads and power cables to avoid possible electromagnetic disturbance. Never run power cables (including the electrical panel wiring) and signal cables in the same conduits.



The product must be installed with the earthconnected, using the special yellow-green terminal on the terminal block. Do not use the neutral for the earth connection.

ICON LEGEND:



NOTE: to focus attention on topics of great importance; in particular on the practical use of the various operations of the product.



ATTENTION: to bring critical issues to the attention of those using the product.



TUTORIAL: to lead the user along using some simple configuration examples of the most common settings.

INDEX

1.	NOTES	6
1.1	FLSTdMScHE release notes	6
2.	INTRODUCTION	7
2.1	Main features	7
2.2	Field connections	8
2.3	Components and accessories	9
3.	HARDWARE installation	10
3.1	I/O configuration	10
3.2	Unit diagrams	19
3.3	Probes installation	20
4.	START UP	21
4.1	SmartKey	21
4.2	pCO Manager	21
4.3	USB Pendrive	21
4.4	Setting the controller's address	22
4.5	Setting the address using a terminal	22
5.	USER INTERFACE	23
5.1	Terminal pGD1	23
5.2	Display	23
5.3	User Menu	23
5.4	MENU DESCRIPTION	25
5.5	Quick configuration	25
6.	FUNCTIONS	26
6.1	Temperature control	26
6.2	Evaporator pumps	26
6.3	Antifreeze control	27
6.4	Compressor rotation	29
6.5	Pump-Down	30
6.6	Compressor management	31
6.7	Eco control and liquid injection	36
6.8	Compressor protections	36
6.9	Compressor alarm prevention	37
6.10	Compressor alarms management	38
6.11	EVD EVO device	38
6.12	Condenser pump	39
6.13	Condenser fans	39
6.14	Free-Cooling	41
6.15	Defrost	41
6.16	4-way valve control	43
6.17	Test functions	43
7.	PARAMETERS TABLE	44
7.1	Info	44
7.2	On-Off	58
7.3	Set	59
7.4	Plant	60
7.5	ExV	61
7.6	Condenser	63
7.7	Compressor	66
7.8	HW-SW	72
7.9	Log-Out	73
8.	SUPERVISOR TABLE	74
8.1	Analog variables	74
8.2	Integer variables	77
8.3	Digital variables	83
9.	ALARMS	90
9.1	Alarms interface	90
9.2	Alarms table	90

1. NOTES

1.1 FLSTDmSCHE release notes

SW version	Manual version	Description
1.0.57 03-02-2013	1.0 24-01-2013	First official release (2 circuits)
1.1.13 14-04-2014	1.1 15-04-2014	Pre-release 4 circuits version
1.1.22 30-05-2014	1.2 30-05-2014	Pre-release 4 circuits version
1.3.0 01-08-2014	1.3 01-08-2014	Pre-release 4 circuits version
1.3.2 08-10-2014	1.4 08-10-2014	Pre-release 4 circuits version
1.3.3 12-11-2014	1.5 12-11-2014	Pre-release 4 circuits version

2. INTRODUCTION

2.1 Main features

FLSTDmSCHE is the CAREL solution for managing chillers and heat pumps with screw compressors.

Usability and display - Easy access to the machine configuration and management parameters with the menu system organised by device (available in the pGD1 terminal). There are three password levels to allow three different access modes to the parameters (read only for assistance, edit for servicing, total access for the manufacturer). The main screen gives quick access to the user functions without a password (information on the status of the machine components, On-Off and machine operating mode, set points) using the UP-DOWN and ENTER keys.

List of functions:

Main features	Up to four compressors with step, stepless
	Up to two compressors with inverter (0-10V or Modbus control ⁽¹⁾)
	Air/Water (A/W) heat pump or chiller
	Water/Water (W/W) heat pump or chiller
	Free-cooling option
	One compressor per circuit
	Single evaporator per machine
Hardware	One separated air condenser per circuit (AW) / Single water circuit per machine (W/W)
	1 pCO5+ Medium (ExtraLarge also) per unit with one compressor
	1 pCO5+ ExtraLarge per unit with two compressors
	1 pCO5+ ExtraLarge and, 1 pCO5+ Medium (ExtraLarge also) per unit with three compressors
	2 pCO5+ ExtraLarge per unit with four compressors
User interface	pGD1
Languages	EN-IT-ES
Unit of measure	Temperature: International (°C) and Imperial (°F)
	Pressure: International (barg) and Imperial (psig)
	Settable data format: dd/mm/yy, mm/dd/yy, yy.mm.dd
Control	PID on startup
	PID during operation
Compressor rotation	FIFO
	LIFO
	Timed
Compressor management	Bitzer compressor data preset
	Hanbell compressor data preset
	RefComp compressor data preset
	Frascold compressor data preset
	Custom Compressor to set all compressor parameters
	ECONomizer circuit valve option
	Liquid injection valve option
EVD EVO driver	EVD EVO Management via FB2 with CAREL protocol
	One EVD per circuit
Scheduling	ON-OFF can be selected for every half hour of the day
Evaporator pump	1-2 pumps
	Timed rotation or by pump alarm condition
Water cooled	1-2 pumps
	Timed rotation or by pump alarm condition
Air cooled	Independent ventilation per circuit or common air circuit
	Fan speed modulation on condensing temperature
	Fan output On-Off for inverter command or dedicated fan
	Optimized startup to short compressor warm-up time
	Up to 3 fan output On-Off per circuit (option available with pCO5+ XL only, without Free-cooling, without compressor inverter control)
Defrost	Simultaneous
	Separate
	Independent
Prevention	Prevention of compressor working limits for condensing and evaporating temperatures
	Evaporator anti-freeze prevention
Alarms	Automatic and manual management
	Log from application
	Log from BIOS
Supervisor protocol	Carel
	Modbus
	LonWorks
	Bacnet ready

⁽¹⁾ The speed setpoint is controlled by modbus, the others safety commands (start, emergency stop, reset alarms) must be connected to the controller pCO5+ by dedicated I/O.

2.2 Field connections

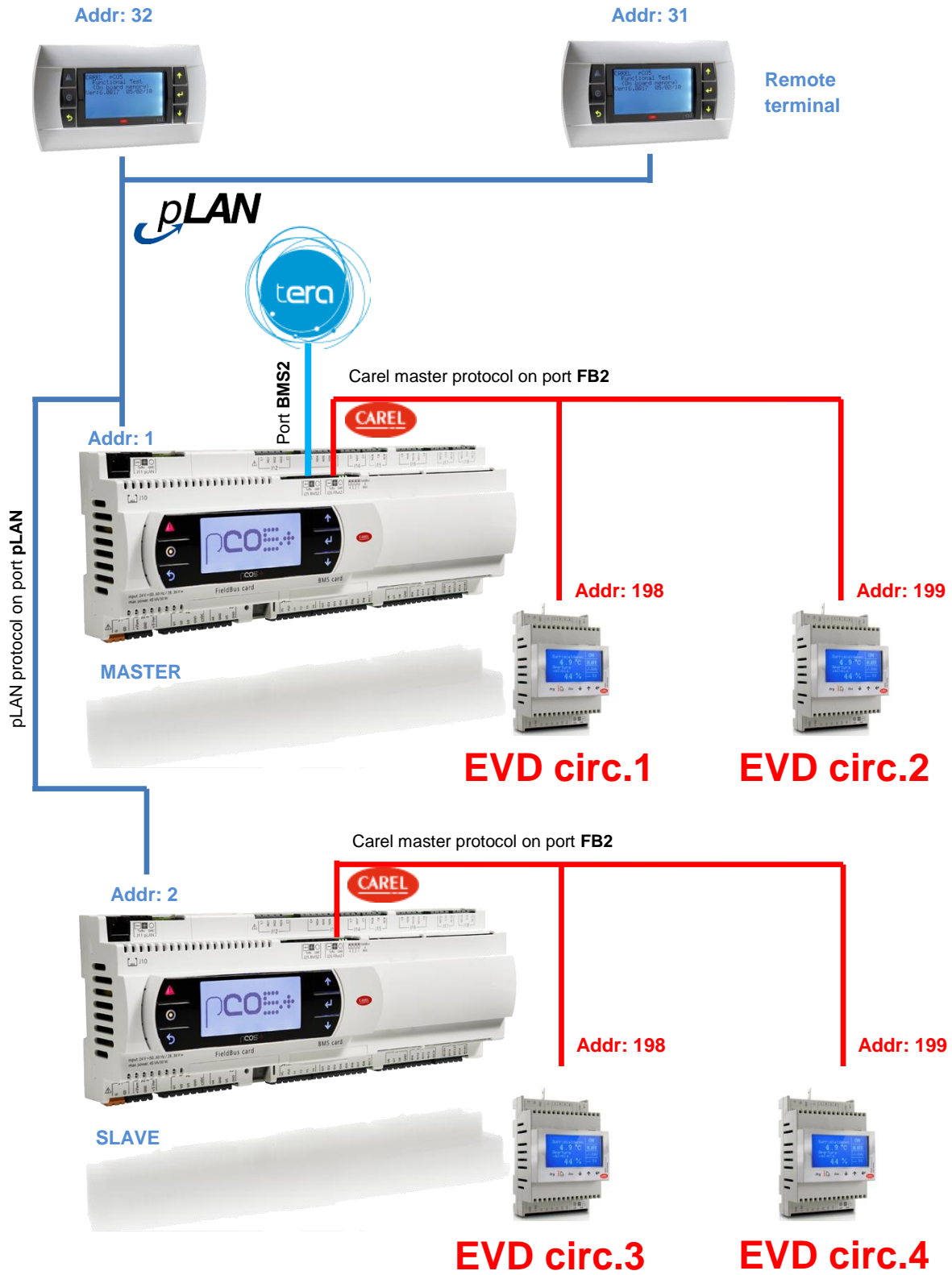

2.3 Components and accessories

FLSTDmSCHE is optimized for pCO5+. The SW can manage up to two screw compressors per board (up to 4 compressors on two boards). Depending on the configuration and type of compressors a different model pCO5+ is necessary.

2.3.1 Table of pCO5+ codes

	Unit type	pCO5+ code	Notes
1	1 screw compressor Step/inverter control	P+500B*A000M0 P+500B*A010M0 P+500B*A050M0	External driver Built-in Carel driver Built-in univ. driver
2	1 screw Bitzer Step control	P+500B*A100M0 P+500B*A110M0 P+500B*A150M0	External driver Built-in Carel driver Built-in univ. driver
3	1 screw compressor Stepless control	P+500B*A200M0 P+500B*A210M0 P+500B*A250M0	External driver Built-in Carel driver Built-in univ. driver
4	2 screw comps. Step/inverter control	P+500B*A000Z0	External driver only
5	2 screw Bitzer Step control	P+500B*A200Z0	External driver only
6	2 screw comps. Stepless control	P+500B*A400Z0	External driver only

Note: not all codes are active, please check the availability before placing the order.

2.3.2 pGDE terminal (optional)

The pGDE graphic display allows the complete management of the user interface through icons and the management of international fonts.

2.3.3 Driver Valve EVD EVO

Every circuit must have a singular type EVD EVO valve driver connected. This choice allows for valve driver redundancy.

The drivers are both connected to the FieldBus2 (FB2) port, native to the pCO5+ controller.

Driver Type	EVD EVO Code
EVD EVO single, CAREL valves	EVD0000E50
EVD EVO single, Universal	EVD0000E20

2.3.4 Temperature sensors

Type	Range	Code
10 kΩ±1%@25 °C, IP67	-50...105/50°C (air/fluid)	NTC*HP*
10 kΩ±1%@25°C (Fast), IP67	-50...105°C (fast)	NTC*WF*
50 kΩ±1%@25 °C, IP55	0...150°C	NTC*HT*

2.3.5 Pressure sensors

Type	Range	Code
0-5V HP R134a	0...34,5bar	SPKT0033R* SPKT0031S*
0-5V LP R134a	-1..9,3bar ¹⁾	SPKT0013R* SPKT0011S*
4-20mA HP R134a	0...30,0bar	SPKT0031C*
4-20mA LP R134a	-0,5..7,0bar ¹⁾	SPKT0021C*



1) In heat pumps reversible cycle it is preferable to use low pressure sensors with wider range, as follows:

Type	Range	Code
0-5V LP R134a	0..17,3bar	SPKT0043R* SPKT0041S*
4-20mA LP R134a	0..18,2bar	SPKT0041C*

2.3.6 FB1 connection cards (inverter compressor)

The inverters are connected to the FieldBus1 (FB1) port of the pCO5+ controller. The Field Bus card is not native in the controller.

FIELD BUS Card	Code
Field Bus RS485 Serial Card	PCO100FD10

2.3.7 BMS connection cards (optional)

The pCO5+ controller has a built in BMS2 port that allows direct interfacing with an RS485 network with maximum baud rate of 19200. Another BMS card can be installed to allow double supervision. The list of cards is below.

BMS Card	Code
BMS RS485 Card	PCOS004850
Ethernet card	PCO1000WBO
BCAnet MS/TP 485 card	PCO1000BA0
Konnex card	PCOS00KXB0
LON	PCO10000F0

2.3.8 EVD UltraCap (optional)

The Ultracap EVD0000UC0 module is an optional device that completes the EVD EVO product with an external backup module for valve closure in the event of a power failure.

The module ensures temporary power to the EVD EVO in the event of a power failure, for enough time to immediately close the electronic valves connected to it. Using the module lets you to avoid the installing of the solenoid valve on the liquid line or the backup battery kit.

The module uses backup Ultracap capacitors (EDLC=Electric Double Layer Capacitor) whose charging is managed independently by the module itself. The Ultracap capacitor ensures longer component life compared to a lead battery module. The estimated life of the Ultracap module is 10 years. Also, since it does not use lead batteries, no special precautions are required in terms of safety and pollution.

3. HARDWARE INSTALLATION

3.1 I/O configuration

Analogue inputs	Master	Slave	Type
U1	Water inlet temperature		NTC
U2	Water outlet temperature		NTC
U3	External temperature (for Air/Water unit) Condenser water temperature (for Water/Water unit)		NTC
U5	Compressor 1 current	Compressor 1 current	0-5V 4-20mA 0-20mA
U6	Compressor 2 current	Compressor 2 current	0-5V 4-20mA 0-20mA

Analogue inputs	Master	Analogue inputs	Slave	Type
EVD 1 – S1	Compressor 1 evaporating pressure	EVD 3 – S1	Compressor 3 evaporating pressure	0-5V 4-20mA 4-20mA remote 4-20mA external
EVD 1 – S2	Compressor 1 suction temperature	EVD 3 – S2	Compressor 3 suction temperature	NTC NTC HT NTC SPKP**T0 0-10V
EVD 1 – S3	Compressor 1 condensing pressure	EVD 3 – S3	Compressor 3 condensing pressure	0-5V 4-20mA 4-20mA remote 4-20mA external
EVD 1 – S4	Compressor 1 discharge temperature	EVD 3 – S4	Compressor 3 discharge temperature	NTC NTC HT NTC SPKP**T0
EVD 2 – S1	Compressor 2 evaporating pressure	EVD 4 – S1	Compressor 4 evaporating pressure	0-5V 4-20mA 4-20mA remote 4-20mA external
EVD 2 – S2	Compressor 2 suction temperature	EVD 4 – S2	Compressor 4 suction temperature	NTC NTC HT NTC SPKP**T0 0-10V
EVD 2 – S3	Compressor 2 condensing pressure	EVD 4 – S3	Compressor 4 condensing pressure	0-5V 4-20mA 4-20mA remote 4-20mA external
EVD 2 – S4	Compressor 2 discharge temperature	EVD 4 – S4	Compressor 4 discharge temperature	NTC NTC HT NTC SPKP**T0

Digital inputs	Master	Slave
ID1	Remote locking alarm	
ID2	Remote Summer/Winter change	
ID3	Remote ON-OFF	
ID4	Evaporator flow switch	
ID5	Condenser flow switch	
ID6	Compressor 1 low pressure switch	Compressor 3 low pressure switch
ID7	Compressor 1 oil level	Compressor 3 oil level
ID8	Fan/condenser pump 1 overload	Fan 3 overload
ID9	Compressor 2 low pressure switch	Compressor 4 low pressure switch
ID10	Compressor 2 oil level	Compressor 4 oil level
ID11	Fan/condenser pump 2 overload	Fan 4 overload
ID12	Evaporator pump 1 overload	
U4	Evaporator pump 2 overload	
ID13	Compressor 1 inverter status (Stop/Run) ⁽²⁾	Compressor 3 inverter status (Stop/Run) ⁽²⁾
ID14	Compressor 2 inverter status (Stop/Run) ⁽²⁾	Compressor 4 inverter status (Stop/Run) ⁽²⁾

Digital inputs	Master	Digital inputs	Slave
EVD 1 – DI1	Compressor 1 high pressure switch	EVD 3 – DI1	Compressor 3 high pressure switch
EVD 1 – DI2	Compressor 1 overload/ Inverter 1 alarm ^(1,2)	EVD 3 – DI2	Compressor 3 overload/ Inverter 3 alarm ^(1,2)
EVD 2 – DI1	Compressor 2 high pressure switch	EVD 4 – DI1	Compressor 4 high pressure switch
EVD 2 – DI2	Compressor 2 overload/ Inverter 2 alarm ^(1,2)	EVD 4 – DI2	Compressor 4 overload/ Inverter 4 alarm ^(1,2)

⁽¹⁾ With inverter compressor, the inverter alarm output must be connected to the EVD driver digital input.

⁽²⁾ Some compressor inverters require external relays between inverter digital outputs and controller digital inputs. Check inverter manual.

 **Attention:** Structure of the software in class A: the thermal protection safeties for overload and high pressure must act directly on the compressor actuator and are thus wired in series with the command for coil of the compressor contactor.

Analogue outputs	Master	Slave	Type	CAREL code
Y1	Condensation circuit 1 fan	Condensation circuit 3 fan	0-10V	FCS3*0
Y2	Condensation circuit 2 fan	Condensation circuit 4 fan	0-10V	FCS3*0
Y3	Inverter request compressor 1 ⁽¹⁾		0-10V	
Y4	Inverter request compressor 2 ⁽¹⁾		0-10V	
U7	Freecooling valve		ON-OFF	CONVONOFF
U8	Evaporator pump 2		ON-OFF	CONVONOFF

⁽¹⁾ If the the inverter is controlled in ModBus, these connections are not needed.

3.1.1 Digital outputs: single circuit version - step compressor (pCO5+ Medium – see table 2.3.1 page 9, types 1-2)

Digital outputs	Description	Bitzer	Hanbell	RefComp	Frascold	Type
NO1	Compressor 1 - Delta relay ⁽²⁾ / Part Winding A relay	-	-	-	-	
NO2	Compressor 1 - Star relay ⁽²⁾ / Part Winding B relay	-	-	-	-	
NO3	Compressor 1 - Solenoid valve	-	-	-	-	
NO4	Compressor 1 - Cycle inversion valve / Antifreeze heaters ⁽³⁾	-	-	-	-	
NO5	Condensation 1 (pump or fan)	-	-	-	-	
NO6	Compressor 1 – Step 1 (V3)	CR3	14	14/20	V1	
NO7	Compressor 1 - Intermittent valve (V1)	CR4				SSR ⁽¹⁾
NO8	Compressor 1 – Step 3 (V4)	CR1	16	16	V3	
NO9	Compressor 1 - Eco Valve	-	-	-	-	
NO10	Compressor 1 - Liquid injection valve	-	-	-	-	
NO11	Evaporator pump 1	-	-	-	-	
NO12	Compressor 1 – Step 2 (V2)	CR2	15	15/21	V2	
NO13	General alarm	-	-	-	-	

⁽¹⁾  **Attention. SSR 24Vdc** unsuitable to directly drive the solenoid valve of capacity control: it is necessary to replay to an external SSR suitable for the load to drive (50-70VA in-rush and 18-20VA in operation).

⁽²⁾ See paragraph 6.6.5 for details on starting up the motor in star-delta configuration.

⁽³⁾ Antifreeze heaters enabled with only chiller unit.

3.1.2 Digital outputs: single circuit version - stepless compressor (pCO5+ Medium - see table 2.3.1 page 9, type 3)

Digital outputs	Description	Bitzer		Hanbell	RefComp	Frascold	Type
		50%	25%				
Min.							
NO1	Compressor 1 - Delta relay ⁽²⁾ / Part Winding A relay	-	-	-	-	-	
NO2	Compressor 1 - Star relay ⁽²⁾ / Part Winding B relay	-	-	-	-	-	
NO3	Compressor 1 - Solenoid valve	-	-	-	-	-	
NO4	Compressor 1 - Cycle inversion valve	-	-	-	-	-	
NO5	Condensation 1 (pump or fan)	-	-	-	-	-	
NO6	Compressor 1 - Startup/shutdown valve (V3)	CR3		14	14		
NO7	Compressor 1 - Load valve (V1)	CR4	CR4	18	16	V1	SSR ⁽¹⁾
NO8	Antifreeze heater	-	-	-	-	-	
NO9	Compressor 1 - Eco Valve	-	-	-	-	-	
NO10	Compressor 1 - Liquid injection valve	-	-	-	-	-	
NO11	Evaporator pump 1	-	-	-	-	-	
NO12	Compressor 1 - Unload valve (V2)	CR2	CR3	15	15	V2	SSR ⁽¹⁾
NO13	General alarm	-	-	-	-	-	

⁽¹⁾  **Attention. SSR 24Vdc** unsuitable to directly drive the solenoid valve of capacity control: it is necessary to replay to an external SSR suitable for the load to drive (50-70VA in-rush and 18-20VA in operation).

⁽²⁾ See paragraph 6.6.5 for details on starting up the motor in star-delta configuration.

3.1.3 Digital outputs: single circuit version - inverter compressor (0-10V) (pCO5+ Medium - see table 2.3.1 page 9, type 1)

Digital outputs	Description	Bitzer	Hanbell	RefComp	Frascold	Type
NO1	Compressor 1 inverter – Start	Start			StartCW/ Enable1	
NO2	Compressor 1 inverter – Emergency shutdown	Coast			Drive On	
NO3	Compressor 1 - Solenoid valve	-			-	
NO4	Compressor 1 - Cycle inversion valve / Antifreeze heaters ⁽¹⁾	-			-	
NO5	Condensation 1 (pump or fan)	-			-	
NO6	Compressor 1 – Step 1 (V3)	-			-	
NO7	Compressor 1 – Step 2 (V2)	-			-	
NO8	Compressor 1 – Step 3 (V4)	-			-	
NO9	Compressor 1 - Eco Valve	-			-	
NO10	Compressor 1 - Liquid injection valve	-			-	
NO11	Evaporator pump 1	-			-	
NO12	Compressor 1 inverter –Alarm reset	Reset			Reset Al.	
NO13	General alarm	-			-	

⁽¹⁾ Antifreeze heaters enabled with only chiller unit.

3.1.4 Digital outputs: dual circuit version - step compressor (pCO5+ XL - see table 2.3.1 page 9, types 4-5)

Digital outputs	Description	Bitzer	Hanbell	RefComp	Frascold	Type
NO1	Compressor 1 - Delta relay ⁽²⁾ / Part Winding A relay	-	-	-	-	
NO2	Compressor 1 - Star relay ⁽²⁾ / Part Winding B relay	-	-	-	-	
NO3	Compressor 1 - Solenoid valve	-	-	-	-	
NO4	Antifreeze heater	-	-	-	-	
NO5	Compressor 1 – Step 3 (V4)	CR1	16	16	V3	
NO6	Compressor 1 – Step 2 (V2)	CR2	15	15/21	V2	
NO7	Compressor 1 – Intermittent valve (V1)	CR4				SSR ⁽¹⁾
NO8	Compressor 1 - Step 1 (V3)	CR3	14	14/20	V1	
NO9	Compressor 2 - Delta relay ⁽²⁾ / Part Winding A relay	-	-	-	-	
NO10	Compressor 2 - Star relay ⁽²⁾ / Part Winding B relay	-	-	-	-	
NO11	Compressor 2 - Solenoid valve	-	-	-	-	
NO12	Compressor 2 - Intermittent valve (V1)	CR4				SSR ⁽¹⁾
NO13	Compressor 2 – Step 1 (V3)	CR3	14	14/20	V1	
NO14	Compressor 2 – Step 2 (V2)	CR2	15	15/21	V2	
NO15	Compressor 2 – Step 3 (V4)	CR1	16	16	V3	
NO16	General alarm	-	-	-	-	
NO17	Evaporator pump 1	-	-	-	-	
NO18	Evaporator pump 2 / Condenser fan 2 circuit 1 ⁽³⁾	-	-	-	-	
NO19	Condenser pump 1 / Condenser fan 1 circuit 1	-	-	-	-	
NO20	Condenser pump 2 / Condenser fan 1 circuit 2	-	-	-	-	
NO21	Compressor 1 - Cycle inversion valve	-	-	-	-	
NO22	Compressor 1 - Eco Valve	-	-	-	-	
NO23	Compressor 1 - Liquid injection valve	-	-	-	-	
NO24	Compressor 2 - Cycle inversion valve	-	-	-	-	
NO25	Compressor 2 - Eco Valve	-	-	-	-	
NO26	Compressor 2 - Liquid injection valve	-	-	-	-	
NO27	Freecooling valve / Condenser fan 3 circuit 1 ⁽³⁾	-	-	-	-	
NO28	Condenser fan 2 circuit 2 ⁽³⁾	-	-	-	-	
NO29	Condenser fan 3 circuit 2 ⁽³⁾	-	-	-	-	

⁽¹⁾  **Attention. SSR 24Vdc** unsuitable to directly drive the solenoid valve of capacity control: it is necessary to replay to an external SSR suitable for the load to drive (50-70VA in-rush and 18-20VA in operation).

⁽²⁾ See paragraph 6.6.5 for details on starting up the motor in star-delta configuration.

⁽³⁾ Output configuration when number of fans set is 2 or 3 (not available with Free-cooling option).

3.1.5 Digital outputs: dual circuit version - stepless compressor (pCO5+ XL - see table 2.3.1 page 9, type 6)

Digital outputs	Description	Bitzer		Hanbell	RefComp	Frascold	Type
		50%	25%				
Min.							
NO1	Compressor 1 - Delta relay ⁽²⁾ / Part Winding A relay	-	-	-	-	-	
NO2	Compressor 1 - Star relay ⁽²⁾ / Part Winding B relay	-	-	-	-	-	
NO3	Compressor 1 - Solenoid valve	-	-	-	-	-	
NO4	Antifreeze heater	-	-	-	-	-	
NO5							
NO6	Compressor 1 - Startup/shutdown valve (V3)	CR3		14	14		
NO7	Compressor 1 - Load valve (V1)	CR4	CR4	18	16	V1	SSR ⁽¹⁾
NO8	Compressor 1 - Unload valve (V2)	CR2	CR3	15	15	V2	SSR ⁽¹⁾
NO9	Compressor 2 - Delta relay ⁽²⁾ / Part Winding A relay	-	-	-	-	-	
NO10	Compressor 2 - Star relay ⁽²⁾ / Part Winding B relay	-	-	-	-	-	
NO11	Compressor 2 - Solenoid valve	-	-	-	-	-	
NO12	Compressor 2 - Load valve (V1)	CR4	CR4	18	16	V1	SSR ⁽¹⁾
NO13	Compressor 2 - Unload valve (V2)	CR2	CR3	15	15	V2	SSR ⁽¹⁾
NO14	Compressor 2 - Startup/shutdown valve (V3)	CR3		14	14		
NO15							
NO16	General alarm	-	-	-	-	-	
NO17	Evaporator pump 1	-	-	-	-	-	
NO18	Evaporator pump 2 / Condenser fan 2 circuit 1 ⁽³⁾	-	-	-	-	-	
NO19	Condenser pump 1 / Condenser fan 1 circuit 1	-	-	-	-	-	
NO20	Condenser pump 2 / Condenser fan 1 circuit 2	-	-	-	-	-	
NO21	Compressor 1 - Cycle inversion valve	-	-	-	-	-	
NO22	Compressor 1 - Eco Valve	-	-	-	-	-	
NO23	Compressor 1 - Liquid injection valve	-	-	-	-	-	
NO24	Compressor 2 - Cycle inversion valve	-	-	-	-	-	
NO25	Compressor 2 - Eco Valve	-	-	-	-	-	
NO26	Compressor 2 - Liquid injection valve	-	-	-	-	-	
NO27	Freecooling valve / Condenser fan 3 circuit 1 ⁽³⁾	-	-	-	-	-	
NO28	Condenser fan 2 circuit 2 ⁽³⁾	-	-	-	-	-	
NO29	Condenser fan 3 circuit 2 ⁽³⁾	-	-	-	-	-	

(1)  **Attention. SSR 24Vdc** unsuitable to directly drive the solenoid valve of capacity control: it is necessary to replay to an external SSR suitable for the load to drive (50-70VA in-rush and 18-20VA in operation).

(2) See paragraph 6.6.5 for details on starting up the motor in star-delta configuration.

(3) Output configuration when number of fans set is 2 or 3 (not available with Free-cooling option).

3.1.6 Digital outputs: dual circuit version - inverter compressor(0-10V) (pCO5+ XL - see table 2.3.1 page 9, type 1)

Digital outputs	Description	Bitzer	Hanbell	RefComp	Frascold	Type
NO2	Compressor 1 inverter – Emergency shutdown	Coast			Drive On	
NO3	Compressor 1 - Solenoid valve	-			-	
NO4	Antifreeze heater	-			-	
NO5	Compressor 1 – Step 3 (V4)	-			-	
NO6	Compressor 1 – Step 2 (V2)	-			-	
NO7	Compressor 1 inverter –Alarm reset	Reset			Reset Al.	
NO8	Compressor 1 - Step 1 (V3)	-			-	
NO9	Compressor 2 inverter – Start	Start			StartCW/ Enable1	
NO10	Compressor 2 inverter – Emergency shutdown	Coast			Drive On	
NO11	Compressor 2 - Solenoid valve	-			-	
NO12	Compressor 2 inverter –Alarm reset	Reset			Reset Al.	
NO13	Compressor 2 – Step 1 (V3)	-			-	
NO14	Compressor 2 – Step 2 (V2)	-			-	
NO15	Compressor 2 – Step 3 (V4)	-			-	
NO16	General alarm	-			-	
NO17	Evaporator pump 1	-			-	
NO18	Evaporator pump 2	-			-	
NO19	Condenser pump 1	-			-	
NO20	Condenser pump 2	-			-	
NO21	Compressor 1 - Cycle inversion valve	-			-	
NO22	Compressor 1 - Eco Valve	-			-	
NO23	Compressor 1 - Liquid injection valve	-			-	
NO24	Compressor 2 - Cycle inversion valve	-			-	
NO25	Compressor 2 - Eco Valve	-			-	
NO26	Compressor 2 - Liquid injection valve	-			-	
NO27	Freecooling valve	-			-	
NO28						
NO29						

3.1.7 Digital outputs: 3 circuit version - step compressor

Master board (pCO5+ XL - see table 2.3.1 page 9, types 4-5)

Digital outputs	Description	Bitzer	Hanbell	RefComp	Frascold	Type
NO1	Compressor 1 - Delta relay ⁽²⁾ / Part Winding A relay	-	-	-	-	
NO2	Compressor 1 - Star relay ⁽²⁾ / Part Winding B relay	-	-	-	-	
NO3	Compressor 1 - Solenoid valve	-	-	-	-	
NO4	Antifreeze heater	-	-	-	-	
NO5	Compressor 1 – Step 3 (V4)	CR1	16	16	V3	
NO6	Compressor 1 – Step 2 (V2)	CR2	15	15/21	V2	
NO7	Compressor 1 – Intermittent valve (V1)	CR4				SSR ⁽¹⁾
NO8	Compressor 1 - Step 1 (V3)	CR3	14	14/20	V1	
NO9	Compressor 2 - Delta relay ⁽²⁾ / Part Winding A relay	-	-	-	-	
NO10	Compressor 2 - Star relay ⁽²⁾ / Part Winding B relay	-	-	-	-	
NO11	Compressor 2 - Solenoid valve	-	-	-	-	
NO12	Compressor 2 – Intermittent valve (V1)	CR4				SSR ⁽¹⁾
NO13	Compressor 2 – Step 1 (V3)	CR3	14	14/20	V1	
NO14	Compressor 2 – Step 2 (V2)	CR2	15	15/21	V2	
NO15	Compressor 2 – Step 3 (V4)	CR1	16	16	V3	
NO16	General alarm	-	-	-	-	
NO17	Evaporator pump 1	-	-	-	-	
NO18	Evaporator pump 2	-	-	-	-	
NO19	Condenser pump 1 / Condenser fan 1 circuit 1	-	-	-	-	
NO20	Condenser pump 2 / Condenser fan 1 circuit 2	-	-	-	-	
NO21	Compressor 1 - Cycle inversion valve	-	-	-	-	
NO22	Compressor 1 - Eco Valve	-	-	-	-	
NO23	Compressor 1 - Liquid injection valve	-	-	-	-	
NO24	Compressor 2 - Cycle inversion valve	-	-	-	-	
NO25	Compressor 2 - Eco Valve	-	-	-	-	
NO26	Compressor 2 - Liquid injection valve	-	-	-	-	
NO27	Freecooling valve	-	-	-	-	
NO28						
NO29						

Slave board (pCO5+ Medium - see table 2.3.1 page 9, types 1-2)

Digital outputs	Description	Bitzer	Hanbell	RefComp	Frascold	Type
NO1	Compressor 3 - Delta relay ⁽²⁾ / Part Winding A relay	-	-	-	-	
NO2	Compressor 3 - Star relay ⁽²⁾ / Part Winding B relay	-	-	-	-	
NO3	Compressor 3 - Solenoid valve	-	-	-	-	
NO4	Compressor 3 - Cycle inversion valve	-	-	-	-	
NO5	Condenser fan 1 circuit 3	-	-	-	-	
NO6	Compressor 3 – Step 1 (V3)	CR3	14	14/20	V1	
NO7	Compressor 3 - Intermittent valve (V1)	CR4				SSR ⁽¹⁾
NO8	Compressor 3 – Step 3 (V4)	CR1	16	16	V3	
NO9	Compressor 3 - Eco Valve	-	-	-	-	
NO10	Compressor 3 - Liquid injection valve	-	-	-	-	
NO11						
NO12	Compressor 3 – Step 2 (V2)	CR2	15	15/21	V2	
NO13						

(1)  **Attention. SSR 24Vdc** unsuitable to directly drive the solenoid valve of capacity control: it is necessary to replay to an external SSR suitable for the load to drive (50-70VA in-rush and 18-20VA in operation).

(2) See paragraph 6.6.5 for details on starting up the motor in star-delta configuration.

3.1.8 Digital outputs: 3 circuit version - stepless compressor

Master board (pCO5+ XL - see table 2.3.1 page 9, type 6)

Digital outputs	Description	Bitzer		Hanbell	RefComp	Frascold	Type
		50%	25%				
Min.							
NO1	Compressor 1 - Delta relay ⁽²⁾ / Part Winding A relay	-	-	-	-	-	
NO2	Compressor 1 - Star relay ⁽²⁾ / Part Winding B relay	-	-	-	-	-	
NO3	Compressor 1 - Solenoid valve	-	-	-	-	-	
NO4	Antifreeze heater	-	-	-	-	-	
NO5							
NO6	Compressor 1 - Startup/shutdown valve (V3)	CR3		14	14		
NO7	Compressor 1 - Load valve (V1)	CR4	CR4	18	16	V1	SSR ⁽¹⁾
NO8	Compressor 1 - Unload valve (V2)	CR2	CR3	15	15	V2	SSR ⁽¹⁾
NO9	Compressor 2 - Delta relay ⁽²⁾ / Part Winding A relay	-	-	-	-	-	
NO10	Compressor 2 - Star relay ⁽²⁾ / Part Winding B relay	-	-	-	-	-	
NO11	Compressor 2 - Solenoid valve	-	-	-	-	-	
NO12	Compressor 2 - Load valve (V1)	CR4	CR4	18	16	V1	SSR ⁽¹⁾
NO13	Compressor 2 - Unload valve (V2)	CR2	CR3	15	15	V2	SSR ⁽¹⁾
NO14	Compressor 2 - Startup/shutdown valve (V3)	CR3		14	14		
NO15							
NO16	General alarm	-	-	-	-	-	
NO17	Evaporator pump 1	-	-	-	-	-	
NO18	Evaporator pump 2	-	-	-	-	-	
NO19	Condenser pump 1 / Condenser fan 1 circuit 1	-	-	-	-	-	
NO20	Condenser pump 2 / Condenser fan 1 circuit 2	-	-	-	-	-	
NO21	Compressor 1 - Cycle inversion valve	-	-	-	-	-	
NO22	Compressor 1 - Eco Valve	-	-	-	-	-	
NO23	Compressor 1 - Liquid injection valve	-	-	-	-	-	
NO24	Compressor 2 - Cycle inversion valve	-	-	-	-	-	
NO25	Compressor 2 - Eco Valve	-	-	-	-	-	
NO26	Compressor 2 - Liquid injection valve	-	-	-	-	-	
NO27							
NO28							
NO29							

Slave board (pCO5+ Medium - see table 2.3.1 page 9, type 3)

Digital outputs	Description	Bitzer		Hanbell	RefComp	Frascold	Type
		50%	25%				
Min.							
NO1	Compressor 3 - Delta relay ⁽²⁾ / Part Winding A relay	-	-	-	-	-	
NO2	Compressor 3 - Star relay ⁽²⁾ / Part Winding B relay	-	-	-	-	-	
NO3	Compressor 3 - Solenoid valve	-	-	-	-	-	
NO4	Compressor 3 - Cycle inversion valve	-	-	-	-	-	
NO5	Condensation 3 (or fan)	-	-	-	-	-	
NO6	Compressor 3 - Startup/shutdown valve (V3)	CR3		14	14		
NO7	Compressor 3 - Load valve (V1)	CR4	CR4	18	16	V1	SSR ⁽¹⁾
NO8							
NO9	Compressor 3 - Eco Valve	-	-	-	-	-	
NO10	Compressor 3 - Liquid injection valve	-	-	-	-	-	
NO11							
NO12	Compressor 3 - Unload valve (V2)	CR2	CR3	15	15	V2	
NO13							

(1)  **Attention. SSR 24Vdc** unsuitable to directly drive the solenoid valve of capacity control: it is necessary to replay to an external SSR suitable for the load to drive (50-70VA in-rush and 18-20VA in operation).

(2) See paragraph 6.6.5 for details on starting up the motor in star-delta configuration.

3.1.9 Digital outputs: 3-4 circuit version - step compressor

Master board (pCO5+ XL - see table 2.3.1 page 9, types 4-5)						
Digital outputs	Description	Bitzer	Hanbell	RefComp	Frascold	Type
NO1	Compressor 1 - Delta relay ⁽²⁾ / Part Winding A relay	-	-	-	-	
NO2	Compressor 1 - Star relay ⁽²⁾ / Part Winding B relay	-	-	-	-	
NO3	Compressor 1 - Solenoid valve	-	-	-	-	
NO4	Antifreeze heater	-	-	-	-	
NO5	Compressor 1 – Step 3 (V4)	CR1	16	16	V3	
NO6	Compressor 1 – Step 2 (V2)	CR2	15	15/21	V2	
NO7	Compressor 1 – Intermittent valve (V1)	CR4				SSR ⁽¹⁾
NO8	Compressor 1 - Step 1 (V3)	CR3	14	14/20	V1	
NO9	Compressor 2 - Delta relay ⁽²⁾ / Part Winding A relay	-	-	-	-	
NO10	Compressor 2 - Star relay ⁽²⁾ / Part Winding B relay	-	-	-	-	
NO11	Compressor 2 - Solenoid valve	-	-	-	-	
NO12	Compressor 2 - Intermittent valve (V1)	CR4				SSR ⁽¹⁾
NO13	Compressor 2 – Step 1 (V3)	CR3	14	14/20	V1	
NO14	Compressor 2 – Step 2 (V2)	CR2	15	15/21	V2	
NO15	Compressor 2 – Step 3 (V4)	CR1	16	16	V3	
NO16	General alarm	-	-	-	-	
NO17	Evaporator pump 1	-	-	-	-	
NO18	Evaporator pump 2 / Condenser fan 2 circuit 1 ⁽³⁾	-	-	-	-	
NO19	Condenser pump 1 / Condenser fan 1 circuit 1	-	-	-	-	
NO20	Condenser pump 2 / Condenser fan 1 circuit 2	-	-	-	-	
NO21	Compressor 1 - Cycle inversion valve	-	-	-	-	
NO22	Compressor 1 - Eco Valve	-	-	-	-	
NO23	Compressor 1 - Liquid injection valve	-	-	-	-	
NO24	Compressor 2 - Cycle inversion valve	-	-	-	-	
NO25	Compressor 2 - Eco Valve	-	-	-	-	
NO26	Compressor 2 - Liquid injection valve	-	-	-	-	
NO27	Freecooling valve / Condenser fan 3 circuit 1 ⁽³⁾	-	-	-	-	
NO28	Condenser fan 2 circuit 2 ⁽³⁾	-	-	-	-	
NO29	Condenser fan 3 circuit 2 ⁽³⁾	-	-	-	-	

Slave board (pCO5+ XL - see table 2.3.1 page 9, types 4-5)						
Digital outputs	Description	Bitzer	Hanbell	RefComp	Frascold	Type
NO1	Compressor 3 - Delta relay ⁽²⁾ / Part Winding A relay	-	-	-	-	
NO2	Compressor 3 - Star relay ⁽²⁾ / Part Winding B relay	-	-	-	-	
NO3	Compressor 3 - Solenoid valve	-	-	-	-	
NO4						
NO5	Compressor 3 – Step 3 (V4)	CR1	16	16	V3	
NO6	Compressor 3 – Step 2 (V2)	CR2	15	15/21	V2	
NO7	Compressor 3 – Intermittent valve (V1)	CR4				SSR ⁽¹⁾
NO8	Compressor 3 - Step 1 (V3)	CR3	14	14/20	V1	
NO9	Compressor 4 - Delta relay ⁽²⁾ / Part Winding A relay	-	-	-	-	
NO10	Compressor 4 - Star relay ⁽²⁾ / Part Winding B relay	-	-	-	-	
NO11	Compressor 4 - Solenoid valve	-	-	-	-	
NO12	Compressor 4 - Intermittent valve (V1)	CR4				SSR ⁽¹⁾
NO13	Compressor 4 – Step 1 (V3)	CR3	14	14/20	V1	
NO14	Compressor 4 – Step 2 (V2)	CR2	15	15/21	V2	
NO15	Compressor 4 – Step 3 (V4)	CR1	16	16	V3	
NO16						
NO17						
NO18	Condenser fan 2 circuit 3 ⁽³⁾	-	-	-	-	
NO19	Condenser fan 1 circuit 3	-	-	-	-	
NO20	Condenser fan 1 circuit 4	-	-	-	-	
NO21	Compressor 3 - Cycle inversion valve	-	-	-	-	
NO22	Compressor 3 - Eco Valve	-	-	-	-	
NO23	Compressor 3 - Liquid injection valve	-	-	-	-	
NO24	Compressor 4 - Cycle inversion valve	-	-	-	-	
NO25	Compressor 4 - Eco Valve	-	-	-	-	
NO26	Compressor 4 - Liquid injection valve	-	-	-	-	
NO27	Condenser fan 3 circuit 3 ⁽³⁾	-	-	-	-	
NO28	Condenser fan 2 circuit 4 ⁽³⁾	-	-	-	-	
NO29	Condenser fan 3 circuit 4 ⁽³⁾	-	-	-	-	

(1)  **Attention. SSR 24Vdc** unsuitable to directly drive the solenoid valve of capacity control: it is necessary to replay to an external SSR suitable for the load to drive (50-70VA in-rush and 18-20VA in operation).

(2) See paragraph 6.6.5 for details on starting up the motor in star-delta configuration.

(3) Output configuration when number of fans set is 2 or 3 (not available with Free-cooling option).

3.1.10 Digital outputs: 3-4 circuit version - stepless compressor

Master board (pCO5+ XL - see table 2.3.1 page 9, type 6)							
Digital outputs Min.	Description	Bitzer		Hanbell	RefComp	Frascold	Type
		50%	25%				
NO1	Compressor 1 - Delta relay ⁽²⁾ / Part Winding A relay	-	-	-	-	-	
NO2	Compressor 1 - Star relay ⁽²⁾ / Part Winding B relay	-	-	-	-	-	
NO3	Compressor 1 - Solenoid valve	-	-	-	-	-	
NO4	Antifreeze heater	-	-	-	-	-	
NO5							
NO6	Compressor 1 - Startup/shutdown valve (V3)	CR3		14	14		
NO7	Compressor 1 - Load valve (V1)	CR4	CR4	18	16	V1	SSR ⁽¹⁾
NO8	Compressor 1 - Unload valve (V2)	CR2	CR3	15	15	V2	SSR ⁽¹⁾
NO9	Compressor 2 - Delta relay ⁽²⁾ / Part Winding A relay	-	-	-	-	-	
NO10	Compressor 2 - Star relay ⁽²⁾ / Part Winding B relay	-	-	-	-	-	
NO11	Compressor 2 - Solenoid valve	-	-	-	-	-	
NO12	Compressor 2 - Load valve (V1)	CR4	CR4	18	16	V1	SSR ⁽¹⁾
NO13	Compressor 2 - Unload valve (V2)	CR2	CR3	15	15	V2	SSR ⁽¹⁾
NO14	Compressor 2 - Startup/shutdown valve (V3)	CR3		14	14		
NO15							
NO16	General alarm	-	-	-	-	-	
NO17	Evaporator pump 1	-	-	-	-	-	
NO18	Evaporator pump 2 / Condenser fan 2 circuit 1 ⁽³⁾	-	-	-	-	-	
NO19	Condenser pump 1 / Condenser fan 1 circuit 1	-	-	-	-	-	
NO20	Condenser pump 2 / Condenser fan 1 circuit 2	-	-	-	-	-	
NO21	Compressor 1 - Cycle inversion valve	-	-	-	-	-	
NO22	Compressor 1 - Eco Valve	-	-	-	-	-	
NO23	Compressor 1 - Liquid injection valve	-	-	-	-	-	
NO24	Compressor 2 - Cycle inversion valve	-	-	-	-	-	
NO25	Compressor 2 - Eco Valve	-	-	-	-	-	
NO26	Compressor 2 - Liquid injection valve	-	-	-	-	-	
NO27	Freecooling valve / Condenser fan 3 circuit 1 ⁽³⁾	-	-	-	-	-	
NO28	Condenser fan 2 circuit 2 ⁽³⁾	-	-	-	-	-	
NO29	Condenser fan 3 circuit 2 ⁽³⁾	-	-	-	-	-	

Slave board (pCO5+ XL - see table 2.3.1 page 9, type 6)							
Digital outputs Min.	Description	Bitzer		Hanbell	RefComp	Frascold	Type
		50%	25%				
NO1	Compressor 3 - Delta relay ⁽²⁾ / Part Winding A relay	-	-	-	-	-	
NO2	Compressor 3 - Star relay ⁽²⁾ / Part Winding B relay	-	-	-	-	-	
NO3	Compressor 3 - Solenoid valve	-	-	-	-	-	
NO4							
NO5							
NO6	Compressor 3 - Startup/shutdown valve (V3)	CR3		14	14		
NO7	Compressor 3 - Load valve (V1)	CR4	CR4	18	16	V1	SSR ⁽¹⁾
NO8	Compressor 3 - Unload valve (V2)	CR2	CR3	15	15	V2	SSR ⁽¹⁾
NO9	Compressor 4 - Delta relay ⁽²⁾ / Part Winding A relay	-	-	-	-	-	
NO10	Compressor 4 - Star relay ⁽²⁾ / Part Winding B relay	-	-	-	-	-	
NO11	Compressor 4 - Solenoid valve	-	-	-	-	-	
NO12	Compressor 4 - Load valve (V1)	CR4	CR4	18	16	V1	SSR ⁽¹⁾
NO13	Compressor 4 - Unload valve (V2)	CR2	CR3	15	15	V2	SSR ⁽¹⁾
NO14	Compressor 4 - Startup/shutdown valve (V3)	CR3		14	14		
NO15							
NO16							
NO17							
NO18	Condenser fan 2 circuit 3 ⁽³⁾	-	-	-	-	-	
NO19	Condenser fan 1 circuit 3	-	-	-	-	-	
NO20	Condenser fan 1 circuit 4	-	-	-	-	-	
NO21	Compressor 3 - Cycle inversion valve	-	-	-	-	-	
NO22	Compressor 3 - Eco Valve	-	-	-	-	-	
NO23	Compressor 3 - Liquid injection valve	-	-	-	-	-	
NO24	Compressor 4 - Cycle inversion valve	-	-	-	-	-	
NO25	Compressor 4 - Eco Valve	-	-	-	-	-	
NO26	Compressor 4 - Liquid injection valve	-	-	-	-	-	
NO27	Condenser fan 3 circuit 3 ⁽³⁾	-	-	-	-	-	
NO28	Condenser fan 2 circuit 4 ⁽³⁾	-	-	-	-	-	
NO29	Condenser fan 3 circuit 4 ⁽³⁾	-	-	-	-	-	

(1)  **Attention. SSR 24Vdc** unsuitable to directly drive the solenoid valve of capacity control: it is necessary to replay to an external SSR suitable for the load to drive (50-70VA in-rush and 18-20VA in operation).
 (2) See paragraph 6.6.5 for details on starting up the motor in star-delta configuration.
 (3) Output configuration when number of fans set is 2 or 3 (not available with Free-cooling option).



Note: Consult the pCO5+ manual (code +0300020EN) for details on installing the pCO5+ controller hardware.

3.2 Unit diagrams

Below are some details on the installation position for the probes referred to the first circuit. We recommend installing them in the position described.

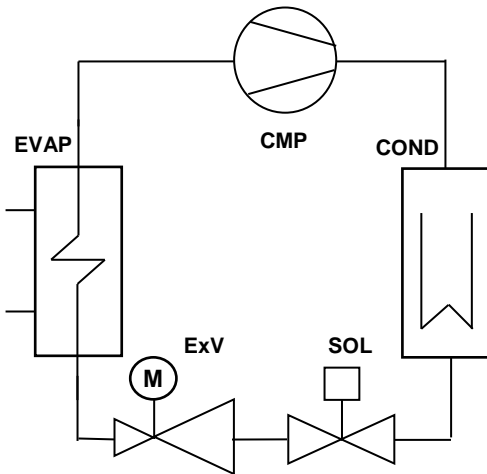

Analogue inputs		Digital inputs	
U1	Water inlet temperature	ID4	Evaporator flow switch
U2	Water outlet temperature	ID6	Circuit 1 LP switch
U3	Outdoor temperature	ID8	Condenser 1 overload
S1	Suction pressure	ID12	Evaporator 1 overload
S2	Suction temperature	ID5	Condenser flow switch
S3	Discharge pressure	EVD DI1	Circuit 1 HP switch
S4	Discharge temperature	EVD DI2	Compressor 1 overload
Devices			
CMP	Compressor		
EVP	Evaporator		
COND	Condenser		
ExV	Expansion valve		
SOL	Liquid solenoid valve		
PMP	Pump		

Compressor probe detail

Evaporator pump detail

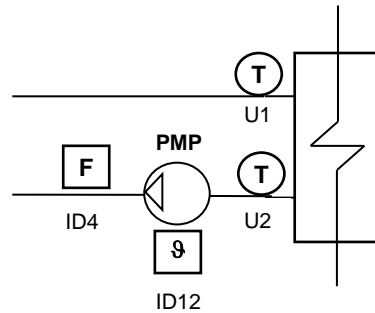
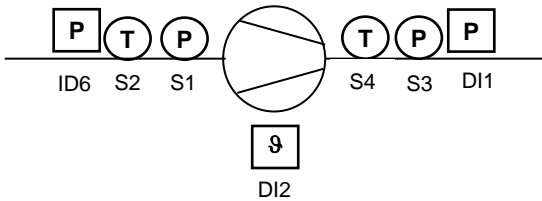

Air cooled detail

Water cooled detail

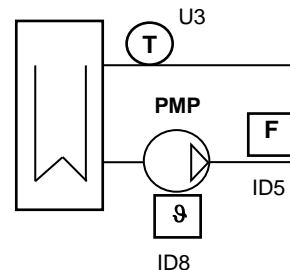
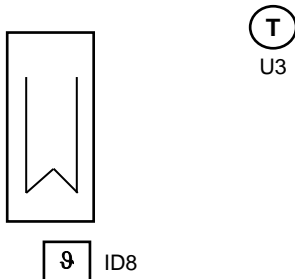

Gas side reversability detail

Water side reversability detail on water/water unit

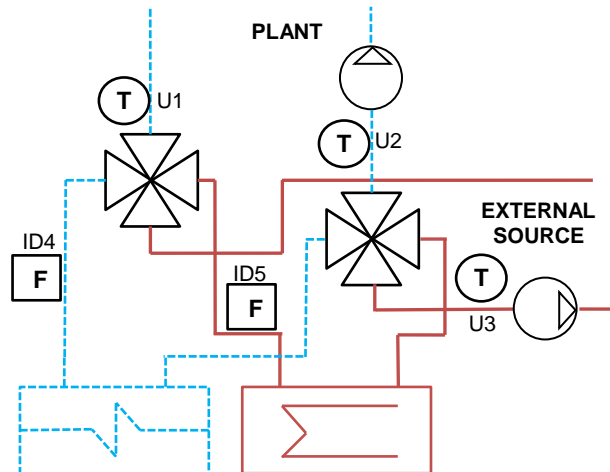
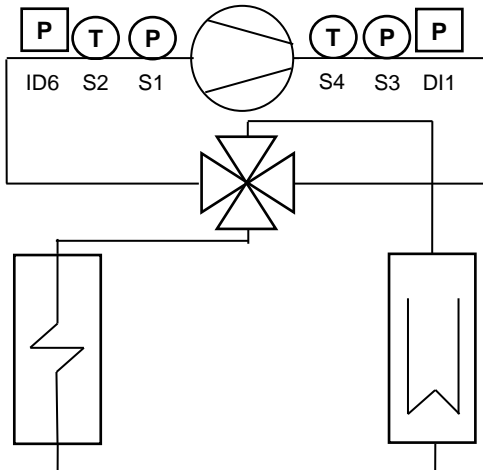

3.3 Probes installation

Some of the details regarding probe installation are described below.

3.3.1 Temperature probes

Follow the instructions below to properly install the temperature probes.

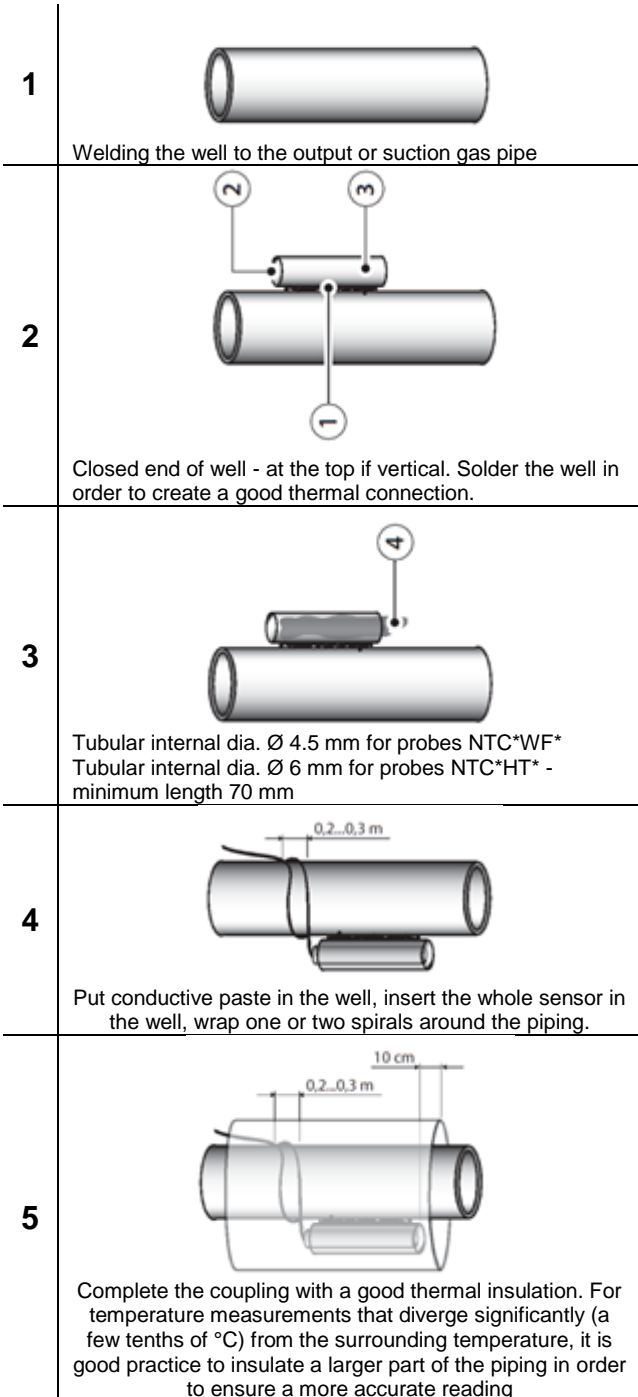

Positioning of discharge gas temperature probes

They should be installed in the upper part of the piping at 30-40 cm from the attachment of the compressor flange so they are not influenced by the thermal mass of the compressor body. Insulate the entire piping tract from the compressor up to and including the probe.

Positioning the suction temperature probe

Proper installation, as shown in the following figure, is important to ensure proper operation of the superheating control; choose a horizontal tract far from curves (at least 6-8 times the diameter) but near the evaporator output.

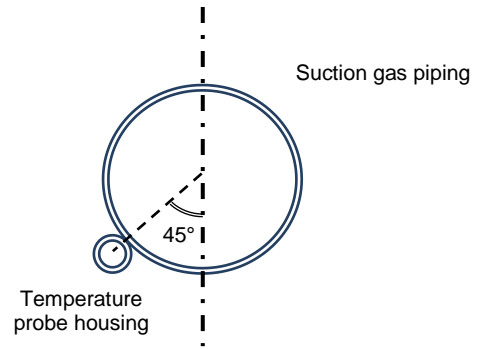

Positioning water input/output temperature probes

Use well that involve at least half of the water flow, as shown in the figure below:

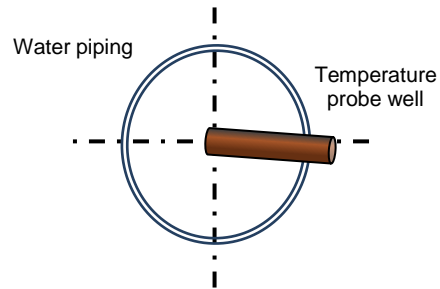

3.3.2 Pressure probes

In general, pressure probes must be installed on the upper part of the gas pipe to prevent the oil in the chiller circuit from obstructing the passage of the gas in the transducer, which is then unable to provide correct readings. It is preferable to use Schrader valves to allow easy replacement of the transducer.

Positioning evaporation pressure probes

They should be installed in the upper part of the suction pipe near the position chosen for the temperature probe.

Positioning condensation pressure probes

They should be installed in the upper part of the discharge gas pipe, far enough away from the compressor to dampen the pulsations that could provide false readings.

4. START UP

The following methods can be used to update the firmware and acquire the log files on pCO controllers:

- Smart Key programming key;
- pCO Manager, a program to install on the PC;
- an USB pendrive.

4.1 SmartKey

The PCOS00AKY0 key is an electronic device used to program and service pCO Sistema controllers. The PCOS00AKY0 key simplifies data transfer between the controllers installed and a personal computer by exploiting the high capacity flash memory for storing software applications, BIOS and variable logs. The pCO is connected directly via the telephone connector using the cable supplied, while to transfer data to a personal computer the PCOS00AKC0 USB adapter is required. The device is powered either by the USB port on the PC or by the controller, therefore no external power supply is necessary.

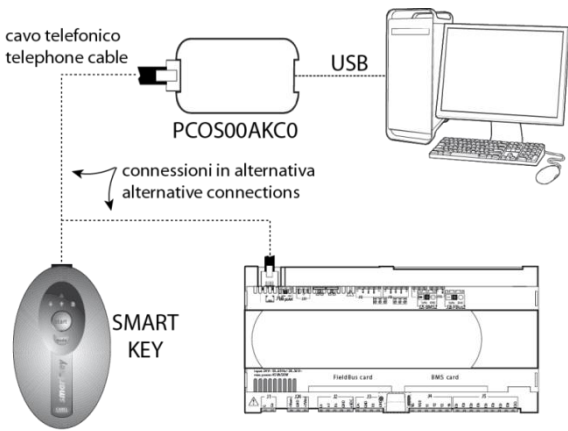

Note: for operating steps see the pCO5+ manual cod. +0300020EN par. 9.1.

4.2 pCO Manager

On all pCO Sistema controllers the resident software can be updated using a PC. For this purpose, CAREL provides the pCO Manager program and a serial converter with RS485 output to connect to the pCO. pCO Manager is part of the “1Tool” program suite; it can also be installed by itself and can be obtained free of charge at <http://ksa.carel.com>, from the section “pCO Sistema”-> “pCO_manager”. The figure below shows the connection diagram.

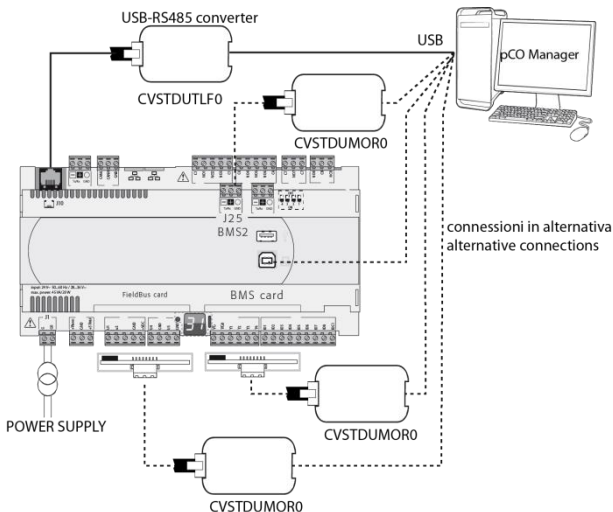

The controller can be connected directly to the PC via the RS485 serial port used for the “pLAN” connection or via the BMS or Fieldbus serial port using the optional RS485 serial card. Lastly, connection can be made using the slave USB port, if present. pCO Manager can communicate with all the programmable controllers of the pCO family. The program can also be used to update and download to the PC the BOOT, BIOS, application program, configuration and log files and also to save files to the NAND flash memory.

As a rule, CAREL advises NOT to update the BOOT; CAREL always loads the BOOT best suited for the controller’s operation during construction. Only in very special cases will CAREL ask the user to update the BOOT. The BIOS can only be updated via the pLAN serial connection. This procedure causes the controller to switch to low-level operation. In this operating mode log data cannot be downloaded to the PC. To bring the controller back to normal communications with pCO Manager, reset the pCO after successfully loading the BIOS. For further information on the operation of pCO Manager see the online help inside the program.

Note: for operating steps see the pCO5+ manual code +0300020EN par. 9.2.

4.3 USB Pendrive

Some pCO5+ models have two different USB ports (host and slave) to be used for installation and diagnostics. The host port can be used to connect USB mass storage peripherals (pendrives, portable hard disks, etc., having a maximum current consumption of 500 mA) with which to carry out various operations:

- upload to the controller files contained in the removable peripheral: (e.g. application, parameters in the buffer memory, configuration files for logs, BIOS);
- download of files from the pCO5+ to the removable peripheral: (e.g. application, parameters in the buffer memory, data logs, BIOS).

Note: the pendrive can be used to perform UPLOAD and DOWNLOAD operations only by means of a terminal, that can be built in or connected to the pLAN controller.

⚠ Attention:

- pendrive must be formatted to the FAT32 file system;
- the pendrive can be accessed up to two levels: APPL\CHILLER\PRI.BIN – but access to file \APPL\CHILLER\VER1\PRI.BIN is not allowed;
- do not use both USB ports at the same time;
- the maximum pendrive capacity supported is 32 GB.

Note: for operating steps see the pCO5+ manual code +0300020EN par. 9.3.

4.4 Setting the controller's address

The controller's pLAN address is factory-set as 1. There are two ways to set a controller's address:

- using the A button (see figure below) located on the left of the 7-segment display. It can be accessed using the tip of a screwdriver ($\varnothing < 3$ mm);
- using a terminal connected to the pLAN network.

Note: to configure the pLAN address with an external terminal, see the pCO5+ manual code +0300020EN par. 6.3.

Using the button to display the pLAN address
Briefly press the A button (no more than 5 s) to display the controller's current pLAN address. Five seconds after releasing the button the display is cleared.

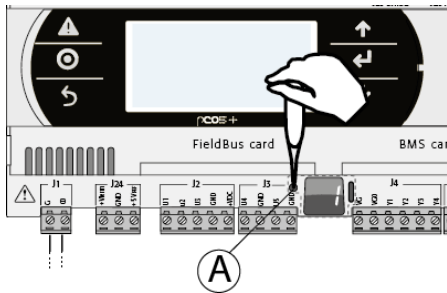

Setting the pLAN address
Procedure:

- Press button A for 5 seconds; the pLAN address starts flashing.
- Press repeatedly or hold the button until reaching the desired address (e.g. 7), then remove the screwdriver.
- Wait until the address starts flashing quickly. The address is now saved but is not yet active for the application program.
- Power off the controller.
- Power on the controller. The address is now active.

4.5 Setting the address using a terminal

After setting the controller address (see previous paragraph), in order to establish the controller-terminal connection, the terminal address must be set.

Procedure:

- Press the UP, DOWN and Enter buttons together. The screen for setting the terminal's address is displayed. Set to the desired address and press Enter to confirm.

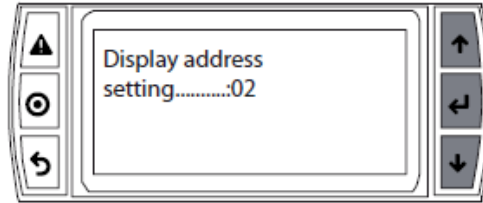

- Press the UP, DOWN and Enter buttons together. Press Enter twice and set the controller's address: 1. Press Enter to confirm.

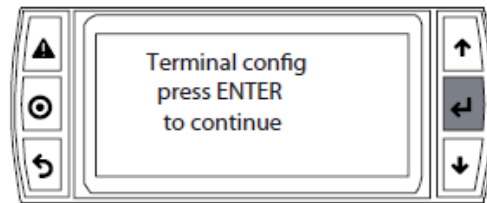
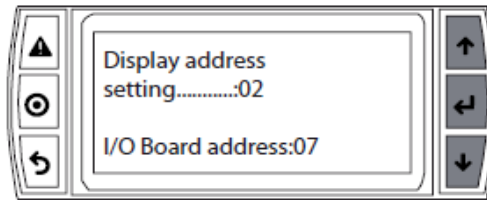

- Set terminal 1 (Trm1) with the desired private address (Priv) and confirm to exit. The connection is established after a few seconds.

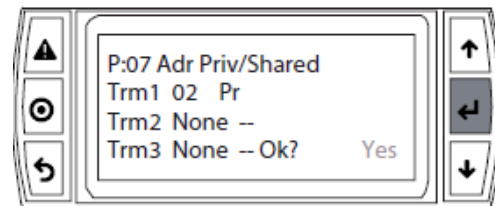

- To add a second terminal repeat the previous steps.

5. USER INTERFACE

5.1 Terminal pGD1

The FLSTDmSCHE user interface is the pGD1 terminal in the wall versions, built-in or mounted directly in the pCO5+, thus "built-in".



The terminal, which is shown in the figure above, has 6 buttons whose meanings are described below:

	- Alarm	Display the list of active alarms Manually reset alarms
	- Prg	Access the main menu
	- Esc	Return to the previous screen
	- Up	Navigate between the display screens or increase/decrease the value.
	- Down	
	- Enter	Switch from parameter display to edit Confirm value and return to the parameter list

5.2 Display

The following screen displays an example of the main screen on an active unit, highlighting the fields and icons used:

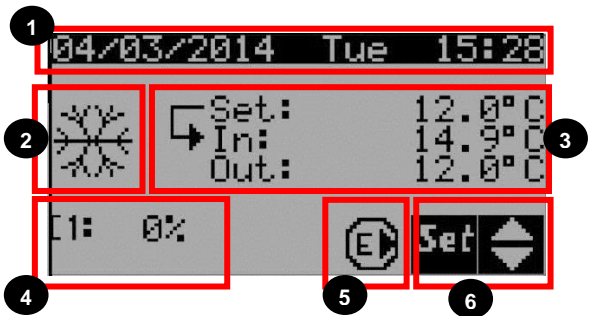

1. Date and Time
2. Current unit status:

	Summer mode (chiller)
	Winter mode (heat pump)
	Defrosting in progress (all circuits)
	Defrosting in progress (only one circuit)
	Full free cooling
	Partial free cooling

3. Control probes, setpoint and reference probe
4. Current power delivered by the compressor
5. Evaporator pump icon (with pump on)
6. Indicates access to the user menu using the UP, DOWN and ENTER keys to confirm

When the unit is off, zones 4 and 5 are hidden and the reason why the unit is off will be displayed. An example follows.

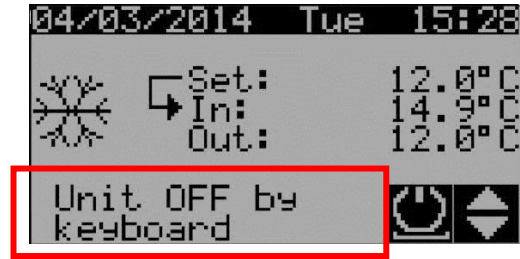

5.3 User Menu

On the main screen, the UP and DOWN buttons can be used to scroll through the functions and ENTER used to select them. No password is needed to access and edit these parameters.

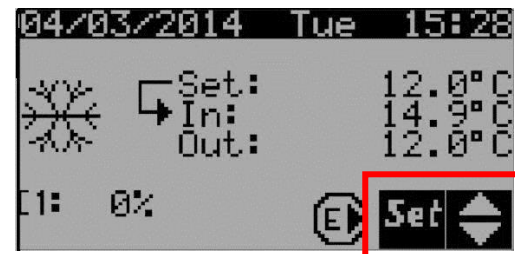

- Info ↑
- On-Off ↓
- Set ↓

5.3.1 Synoptics

The general synoptics of the unit can be shown from the user menu. The physical status of the inputs, device outputs and probes are available in a menu connected to the synoptics. If an input or output is not enabled, its screen does not appear. The individual screens of the synoptics are shown below.

Compressor synoptic

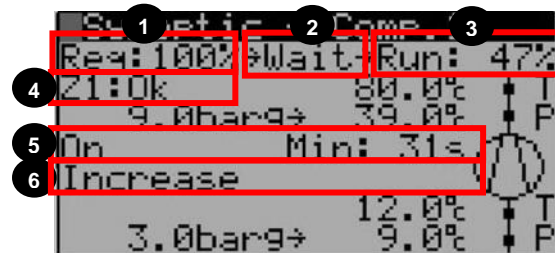

1. Compressor request for thermoregulation
2. Status of the request processed:
 - Off: compressor off
 - Get: power reached
 - Wait: power request in progress (due to the delay between steps or due to movement of the slide)
 - Man: compressor in manual
 - Rot: compressor forced off due to timed rotation
 - Defr: circuit in defrost
 - PmpD: compressor in pumpdown
 - Prev: compressor limited for prevention
 -
3. Current power delivered
4. Envelope zone:
 - Z1:Ok: zone within operating limits
 - Z2:HiDP: High compression ratio
 - Z3:HiDscgP: High condensing pressure
 - Z4:HiCurr: High motor current

- Z5:HiSuctP: High suction pressure
 - Z6:LoDP: Low differential pressure
 - Z7:LoPRat: Low compression ratio
 - Z8:LoDscgP: Low condensing pressure
 - Z9:LoSuctP: Low evaporating pressure
5. Compressor status:
 - Off and countdown minimum off time
 - On and countdown minimum on time
 - Alarm
 - Manual
 - Forced Off
 6. Compressor control phase
 - Start
 - Start 2 (only for stepless)
 - Increase (only for stepless)
 - Decrease (only for stepless)
 - Fast decrease (only for stepless)
 - Stable (only for stepless)
 - Step active (only for step)
 - Off
 - Off 2 (only for stepless)

Condensation fan synoptic

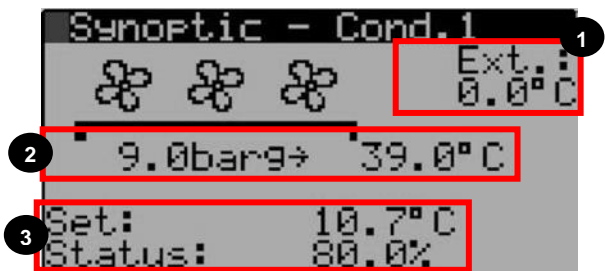

1. External temperature conditions;
2. Condensing pressure and temperature (converted) conditions
3. Control setpoints and percentage request (the percentage is shown with modulating fans only)

ExV synoptic

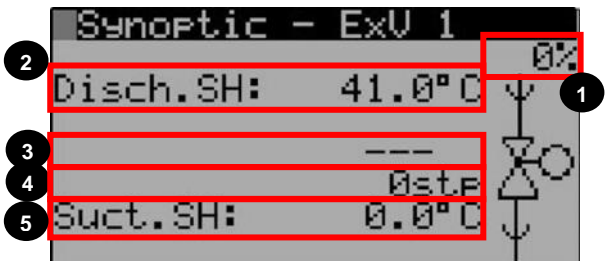

1. Valve opening percentage;
2. Discharge superheat;
3. Valve status:
 - Close: valve closed;
 - Std-by: valve in standby;
 - Pos: valve in positioning;
 - Wait: valve in activation;
 - On: valve in control;
 - Init: driver initialization.
4. Valve steps;
5. Suction superheat

Plant synoptic

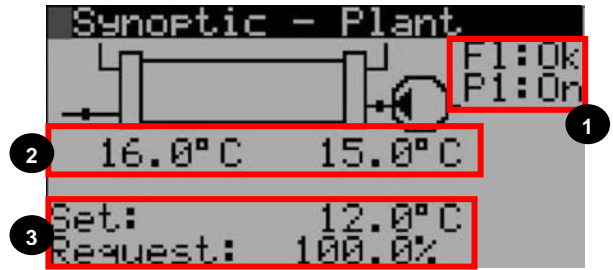

1. Pump and flow switch status
2. Input and output water temperature;
3. Control setpoints and unit percentage request

5.3.2 On-Off

The unit can be turned on and off from the user menu (using the parameter with code **Q001**) and the status can be displayed.

The On status requires the AND logic of:

- digital input (if enabled)
- keyboard from the On-Off menu
- time bands (if enabled)
- BMS (if enabled)

Before switching from On to Off, FLSTDmSCHE goes through the transitory shutting down status where the controller shuts down the compressors following the shutdown procedure and then shuts down pumps and fans.

The Off status requires the OR logic of:

- digital input (if enabled)
- keyboard from the On-Off menu
- time bands (if enabled)
- BMS (if enabled)

5.3.3 Set

In this menu the current setpoints in chiller mode (parameter code **Q002**) and heat pump mode (parameter code **Q003**) can be displayed and edited.

The user cannot set the setpoints outside of the minimum and maximum values set in the Plant menu.

If the summer/winter change by keyboard is enabled, the unit operating mode (parameter code **Q004**) can also be changed in this menu.

Following a mode change, the unit will remain off with the pump on for a period of time (code **A010**) that can be set from the Plant menu to reduce working mode temperature difference in the evaporator and make the compressor restarting less problematic. Otherwise it will have a high thermal load.

The following can also be set in this menu:

1. Clock (code **Q008, Q009**)
2. Date (code **Q005, Q006, Q007**)
3. Scheduler

The FLSTDmSCHE scheduler let the unit be set in:

- Automatic
- Off by time zone
- On by time zone

Unit operation can be set for each day and each half hour of the day. Scheduler can also be created for a day and then copied to others if they are to be reused.

5.4 MENU DESCRIPTION

Regardless of the displayed screen, pressing the programming key accesses the password entry screen which allows access to the main menu shown below.

A.		Plant	
B.		ExV	
C.		Condenser	
D.		Compressor	
			Da. Config.compressor
			Db. Ccustom compressor
			Dc. Inverter compressor
E.		HW/SW	
F.		Log-Out	

5.4.1 Password Management

The program has 3 different password levels:

1. Advanced user (maintenance): read only access to all parameters. Default password: 1234.
2. Service: read access to all parameters with the ability to edit some of them (for more information on the parameters that can be changed, see the parameters table). Default password: 1234.
3. Manufacturer: read/write access to all parameters. Default password: 1234.

As soon as the password is entered in the menu screen, the type of password can be seen, as shown in the following screen:

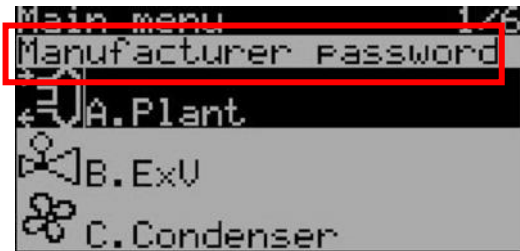

In the parameters screen, the access needed to edit the parameters is shown, always with the same codes. An example follows.

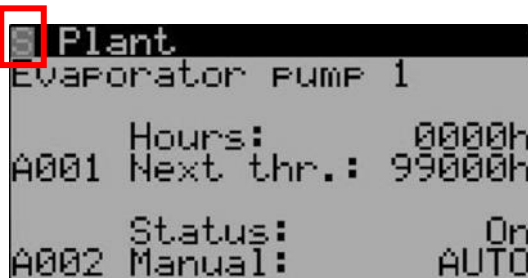

Once the password is entered it will be maintained for 5 minutes from the last time a key was pressed and then the password will need to be re-entered in order to access the parameters of the advanced functions. In the Log-Out menu, the password can be force entered without waiting 5 minutes.

5.4.2 Parameters code

FLSTDmSCHE has a code for each individual parameter to clearly identify them. Only the parameters are coded and thus the values that can be accessed in read/write mode that characterise how the unit operates. The read only values are not coded. Each parameter has a 4 digit code identified as follows:

1st digit	2nd digit	3rd	4th
Main menu code	Secondary menu code	Parameter code	

5.5 Quick configuration

For quick plant configuration, proceed as follows.

Menu A. Plant

Plant has all of the parameters for the evaporator and thus the unit load.

1. Heat pump present (parameter code **A042**)
2. Pump number (parameter code **A043**)

Menu B. ExV

ExV has all of the parameters for the electronic expansion valve and the solenoid valve.

1. ExV Type (parameter code **B043**)
2. ExV control (parameter code **B044**)
3. Pump-down configuration (parameter code **B037**)

Menu C Condenser

Condenser has all of the parameters for the unit condensation.

1. AW or WW unit type (parameter code **C047**)
2. Pump number with WW unit (parameter code **C045**)

Menu Da. Config. compressor

Config. compressor has all of the compressor parameters.

1. Compressor manufacturer (parameter code **Da83**)
2. Compressor model (parameter code **Da84**)
3. Number of compressors (parameter code **Da77**)
4. Refrigerant (parameter code **Da78**)
5. Probe configuration
6. Compressor ignition type (parameter code **Da42**)

Menu E. HW/SW

HW/SW has all of the parameters for the pCO5+ configuration and the specific SW functions that are not related to unit management.

Menu F. Log-Out

Log-Out can be used to exit the set password or change the access password.

6. FUNCTIONS

6.1 Temperature control

FLSTDmSCHE allows the control of the water input or output temperature for the unit. Regardless of the machine reversability type, water or gas side, the U1 and U2 probes will always be the water input and output temperature probes respectively. For further information, see the Hardware Installation chapter.

6.1.1 PID control

There are two types of PID control:

- PID control on startup
- PID control during operation

The following parameters can be set for each PID:

- Control probe (water input or water output)
- Proportional band
- Integral time (action disabled with time at 0)
- Derivative time (action disabled with time at 0)

The adjustment setpoint and the operating mode (hot/cold) will be the same for both controllers.

The startup control must prevent an excess of requested power. Since at startup the status of the load is not known but only the temperature is, the power must be entered little by little, waiting for the reaction of the system. It can regulate on the value of the water input temperature using a wide proportional band (2-3 times the nominal thermal gradient) and a large enough integral time that is greater than the system time constant (120-180s, considering a system time constant of at least 60sec related to a minimum water content of 2.5l/kW).

The control during operation must be quick in order to follow any load variations and maintain the output water temperature as close to the setpoint value as possible. In this case, the time constant is given by the reaction of the compressor - evaporator system and is in the order of a few tens of seconds (slower with shell and tube evaporators, faster with plate evaporators).

The following table shows the suggested values (to be adjusted if necessary during system commissioning) depending on the type of evaporator used.

PID parameter	Param. code	Shell & tube	Plates
Startup - Reg. probe	A011	Input	Input
Startup - Proportional	A015	12°C	12°C
Startup - Integral	A016	180s	180s
Startup - Derivative	A017	0s	0s
Run - Reg. probe	A013	Output	Output
Run - Proportional	A018	10°C	10°C
Run - Integral	A019	20s	15s
Run - Derivative	A020	5s	5s

The control operating procedure is as follows:

1. With the unit Off, both PIDs are disabled
2. When the unit is turned on after the settable pump - compressor delay (A024), the startup PID is enabled and generates a percentage request that will be processed to activate the compressors;
3. If the request is sufficient, one compressor will be turned on;
4. Once the compressor is on, after a settable delay (A012), there is the switching to the PID control during operation.
5. When the operation controller requests the shutting down of the compressors, they can shut down.
6. Once the last compressor is off, the control starts again with the startup PID controller configured.



Note: If the delay A012 between startup and operation PID control is set to 0, the active controller will always be the operation PID.

To best appreciate the control temperature variations, both the water input and water output are read in high resolution in hundredths of °C. This allows a more linear control response even with derivative components, without the "hunting" caused by low system resolution with derivative controls.

The PID controllers integrate the "anti-windup" function that limits the integral action when the request has reached the maximum and minimum limits.

6.1.2 BMS compensation

The setpoint change can be managed through the BMS and external logic. This intervenes only if enabled (see the supervisory table for the specific addresses). The analogue data is not saved in the buffer memory of the pCO, therefore the value must be sent at least every time the controller is turned on.

6.1.3 High water temperature alarm

FLSTDmSCHE activates an alarm when the water temperature exceeds a threshold set by the user (A048) (relative to set point of thermoregulation) during operation of the machine.

This signal can be used to activate a backup machine in case of critical applications.

When the outlet temperature exceeds the threshold, a counter is activated and after the time-out (A050), the alarm is activated.

An initial delay (A049) inhibits the alarm in the unit startup transient.

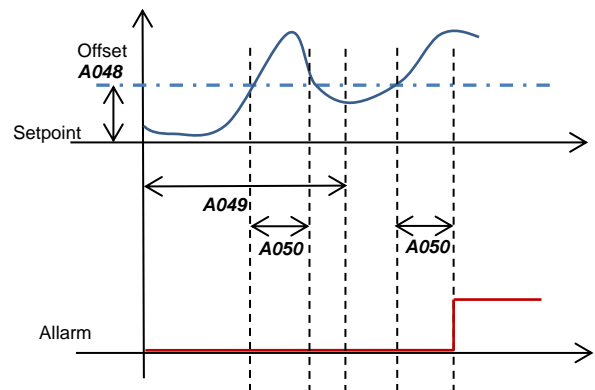

Note: This control is present in chiller-only units.

6.2 Evaporator pumps

FLSTDmSCHE manages up to two pumps on evaporator side.

A delay can be set between the pump startup and thermoregulation enabling (A023). A delay can also be set between the shutdown of the last compressor and pump shutdown (A024). If on unit shutdown the compressors are off for at least the pump off delay time (A024), then the pump shuts down immediately.

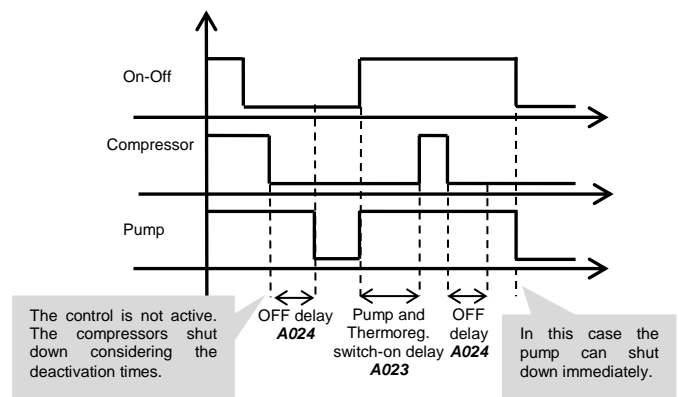

The following diagram shows operation with a single pump:

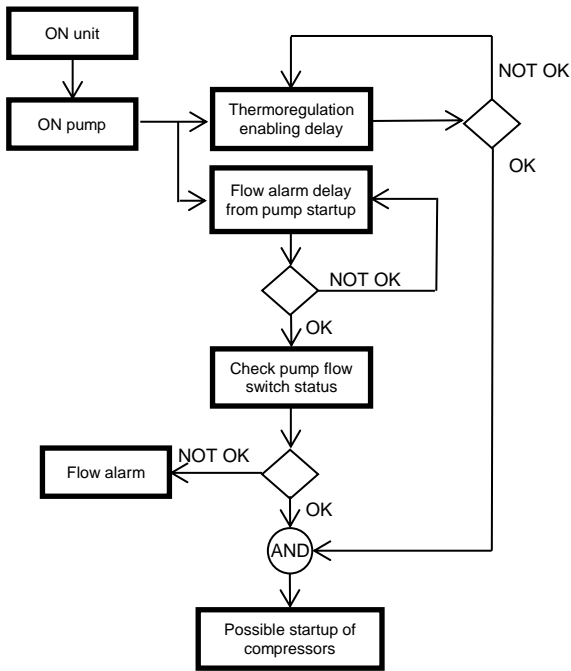

Note that the thermoregulation is not enabled until stable flow conditions are detected after the flow alarm delay from pump startup. This is to prevent the starting up of compressors when there is not yet certainty of the water flow presence.

Up to two evaporator pumps can be enabled. FLSTDmSCHE has the following functions:

- With two pumps, automatic alternating between the pumps to ensure the circulation of the fluid and equalize the hours of operation. Automatic alternation is generated:
 - After a period of time that can be set in hours (A025).
 - With pump overload active.
- Management of the pump overload. Signalling of the anomaly and immediate shutdown of the pump.
- Management of the flow switch that controls the circulation of the fluid in the system.
- Management of the antifreeze with the unit off through startup of the pump to activate the circulation of the fluid (with the unit on, the function is disabled).

6.3 Antifreeze control

6.3.1 Antifreeze alarm

The antifreeze control is performed by the evaporation probe, as it gives a direct reading of the evaporator conditions. The water output probe is not taking into consideration for the antifreeze since it does not precisely measure the possibility or presence of ice inside the evaporator. When the circuit evaporation goes into antifreeze conditions, it is shut down for alarm. Each circuit manages its own evaporation pressure probe, so even the evaporator antifreeze alarm is divided between the circuits.

The evaporating temperature values is filtered according to the exponential distribution formula to consider the thermal mass of the evaporator and avoid timely alarms during startup. A specific algorithm uses this filtered value and intervenes when the antifreeze threshold is exceeded. The following is an operation diagram of the filter of the evaporation temperature, filtered according to the exponential distribution formula.

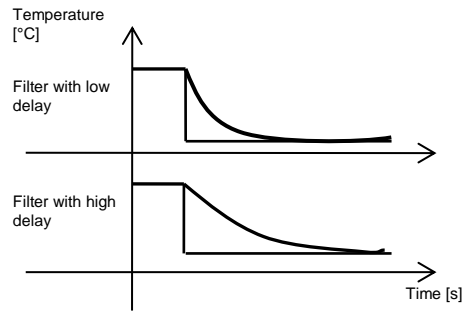

When the control temperature goes below the set (A028), a counter is activated and the time-out for that counter is changed depending on the evaporating temperature distance from the antifreeze threshold, down to zero at the maximum delta (A029) following a hyperbolic curve. This curve imitates the actual behaviour of the icing, allowing better protection. The following diagram shows the delay time trend based on the distance from the alarm threshold and the default values (delay=60s; Diff.=30K). On the threshold, delay is equal to 10 times the set value (600s in the example).

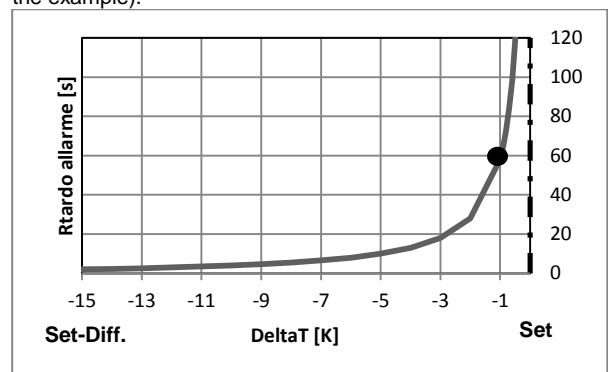

The value suggested in the example refers to a shell and tube evaporator. If a plate evaporator is used, that has a thermal mass that is much smaller, the time (A030) must be reduced to a suitable value. The table below shows the suggested values for the delay and differential depending on the type of evaporator used.

Antifreeze parameter	Param. code	Shell and tube	Plates
Differential	A029	30°C	30°C
Delay	A030	60s	20s

The following diagram shows the alarm operation:

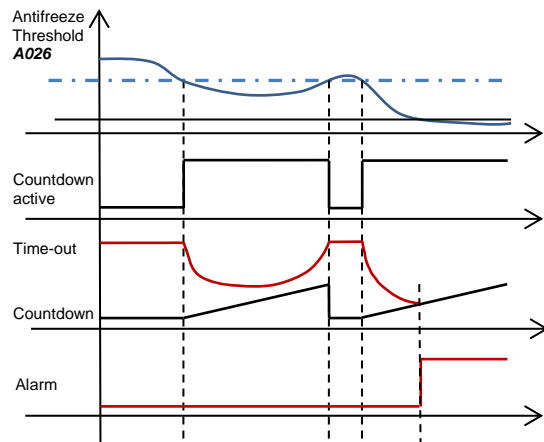

6.3.2 Antifreeze prevention

If envelope management is enabled, the antifreeze set on the evaporator temperature is used as a threshold for the minimum evaporating temperature in the envelope for prevention purposes. In fact, the management of the envelope limits the power of the compressor if the threshold is exceeded.

Also the antifreeze prevention is performed using the evaporating pressure probe.

6.3.3 Evaporator antifreeze management

When the unit is off, FLSTDmSCHE manages the evaporator antifreeze (and the condenser one for Water/Water units) with a configuration parameter (**A041**) that prevents the icing of the water by means of a pump and/or antifreeze heaters. When the water temperature in the evaporator (or condenser) reaches the activation threshold (**A026**), the antifreeze device is activated (the measurement probe is the one located in output of the exchanger).

The devices can be configured as follows:

- Antifreeze with heater (through antifreeze heater that turns on only when the pump is off);
- Antifreeze with pump (the evaporator pump is turned on with antifreeze condition, while the heater is not managed);
- Antifreeze with pump and heater (both devices are turned on).

6.4 Compressor rotation

If only one compressor is present, the request generated by the thermoregulation will be exactly the percentage request that the compressor must meet.

If, on the other hand, the machine is configured with two compressors, FLSTDmSCHE must manage the rotation logic of the compressors in order to match the hours of operation and the compressor peaks and best satisfy the power requested by the temperature control.

6.4.1 Types of rotation

FLSTDmSCHE turns the compressors on in order to match the hours of operation and the peaks. For this reason there are two types of rotation. Below we describe the possibilities and characteristics of the various types of rotation. They do not vary by type of compressor modulation, whether stepless or step.

FIFO rotation

In FIFO (First In First Out) rotation, the first compressor to turn on will be the first one to shut down. This type of rotation is the most common but it penalizes the compressors that are shut down for maintenance or alarms since it simply controls the startup and shutdown sequence.

Timed rotation

In timed rotation, the first compressor to turn on will be the one with fewer hours of operation while the first one to shut down will be the one with more hours of operation. Thus the rotation logic controls the hours of operation of the compressors. This information can be verified in the compressor screens in the I/O menu. If the hours of operation of the compressors are equal, the FIFO rotation described previously will be substituted for timed rotation.

LIFO rotation

In LIFO (Last In First Out) rotation, the first compressor to turn on will be the last one to shut down. This type of rotation is rarely used because it does not equalize the hours of operation of the compressors but keeps the first compressor on as long as possible while the second compressor is turned on only with full cooling demand. The first compressor will need more maintenance than the second.

6.4.2 Power distribution

FLSTDmSCHE provides management of the power distributed to the compressors in the best way possible to increase the efficiency of the unit. The power distribution behaviour changes according to the compressor used, if it has stepless or step modulation. The following describes the parameters involved and the different behaviour of the two types of compressor.

To avoid over delivery of power and allow the first compressor turned on to get to operating speed before starting another, a delay parameter can be set on startup (*Da09*) and shutdown (*Da10*) between compressors. The two delay times, rising and descending, can be reached from the "Compressors" menu. The rising count starts as soon as a compressor is turned on, while the descending count starts as soon as a compressor is shut down.

Step compressor power distribution

FLSTDmSCHE manages the two types of power distribution. The first is called CCpppp (where "C" stands for compressor and "p" stands for partialisation) and turns both compressors on before bringing the partialisation of the compressors to 100%. The second type of distribution is called CppCp because it brings the first compressor to 100% before starting the second. The choice of compressors is controlled by the type of rotation.

The following is a power distribution example with two step compressors with 3 control steps with power 33%, 66% and 100%.

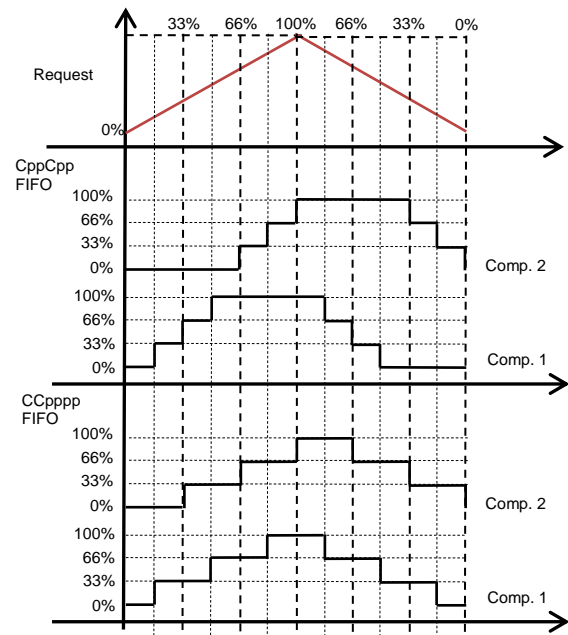

Stepless compressor power distribution

The modulation of compressors with stepless control has the same types seen for the modulation of step compressors. The first is called CCpppp and turns both compressors on before bringing the partialisation of the compressors to 100%. The second is called CppCp because it brings the first compressor to 100% before starting the second. While there are intermediate control phases for step modulation compressors, for stepless compressors the only limit to stepless modulation is the minimum deliverable power of the compressor.

The following is a power distribution example with two compressors with stepless modulation and minimum power of 33%:

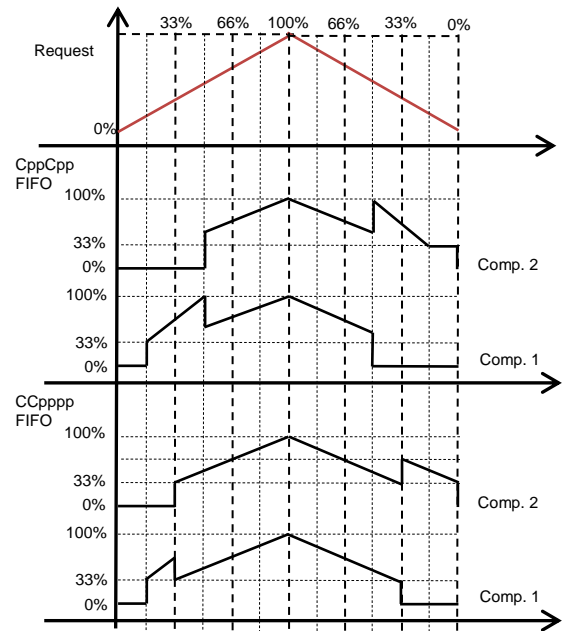

As shown in the graph, FLSTDmSCHE tries to distribute the power to both modulating compressors to bring them to the same power. The behaviour of the compressors only changes at startup and shutdown.

The graph also shows that when the second compressor starts up, the first lowers its power in order to meet the thermoregulation request.

6.4.3 Rotation for alarm

In the event of an alarm for one compressor, the next available compressor will be turned on as a replacement if the request is high enough.

For units with two circuits and prevention active in one circuit, the rotation will compensate for the limited compressor by increasing the request on the available compressor.

6.4.4 Forced rotation

Some compressor manufacturers specify that in units with two compressors, they must be rotated after a certain amount of time in which one only is on, even if control has reached a stable point (parameter **Da11**).

Besides keeping the hours of operation equalized, this procedure avoids the migration of refrigerant during long pause periods and keeps the compressor in temperature.

6.5 Pump-Down

The purpose of the pump-down function is to reduce the quantity of refrigerant in the evaporator to limit the presence of liquid in suction during the compressor startup phase.

Pump-down can be controlled by the electronic expansion valve (ExV) or the solenoid valve combined with the ExV valve.

In general, the pump-down can be activated in two phases: at compressor start up or shut down. FLSTDmSCHE manages the pump-down in both phases. In the compressor shutdown phase it stops when the evaporation pressure reaches the pump-down end setpoint. In the compressor startup phase, the pump-down ends when the pressure difference between discharge and suction reaches the nominal value if prevention is enabled (automatically calculated by the shape of the envelope) or the minimum evaporation pressure threshold is reached.

In both pump-down management methods, if the threshold is not reached within a certain time, the procedure is considered complete. In this case, a pump-down not completed event is saved in the alarms log.

Note: The shutdown pump-down is also performed in the event of shutdowns for alarms that are not serious. It is not performed during defrosting.

6.5.1 Pump-down with ExV

The use of the ExV to perform the pump-down phase allows slower closure compared to the solenoid valve, thus avoiding the pressure wave due to the movement inertia of the fluid ("water hammer") that, if it persists, could break the weaker devices affected by impulse overpressure.

CAREL offers an UltraCap module that allows the valve to be closed following a blackout, ensuring the intercept of the liquid in any situation and thus allowing the solenoid valve to be omitted.

Below we see how the pump-down procedure is performed with only the ExV:

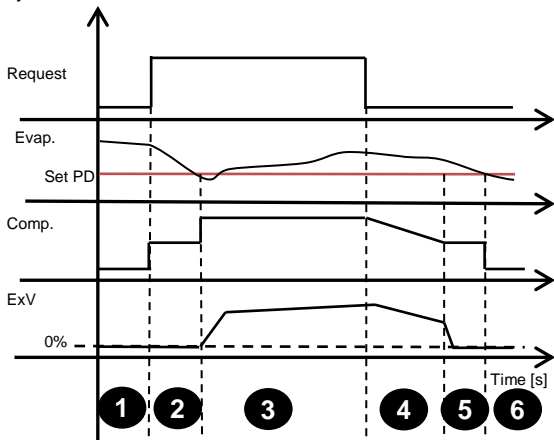

In the pump-down, there are 6 control phases:

	Comp.	ExV	Solenoid valve
1	OFF	0%	---
2	Start-up + Pump-Down	0%	---
3	Modulation	SH control	---
4	Shut-down	SH control	---
5	Minimum + Pump-Down	0%	---
6	OFF	0%	---

Whenever there is a solenoid valve, even if not used for the pump-down, it exactly follows the compressor behaviour, as shown in the graph.

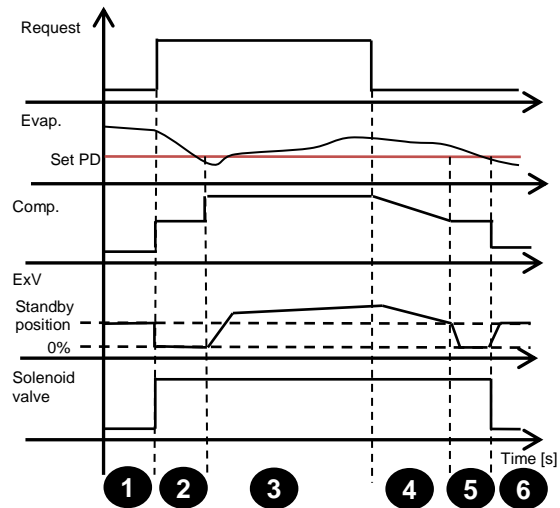

The 6 control phases become the following:

	Comp.	ExV	Solenoid valve
1	OFF	Stand-by (open 25%)	OFF
2	Start-up + Pump-Down	0%	ON
3	Modulation	SH Control	ON
4	Shut-down	SH Control	ON
5	Minimum + Pump-Down	0%	ON
6	OFF	Stand-by (open 25%)	OFF

6.5.2 Pump-down with ExV and solenoid

The ExV can still coexist with the solenoid valve provided that this last remains open during the compressor shut down: this condition is automatically managed when configuring the presence of solenoid valve. If both valves are closed, the liquid between the two interceptions can cause an overpressure that is dangerous for the integrity of the valves themselves.

Below we see how the pump-down procedure is performed with the ExV and solenoid present:

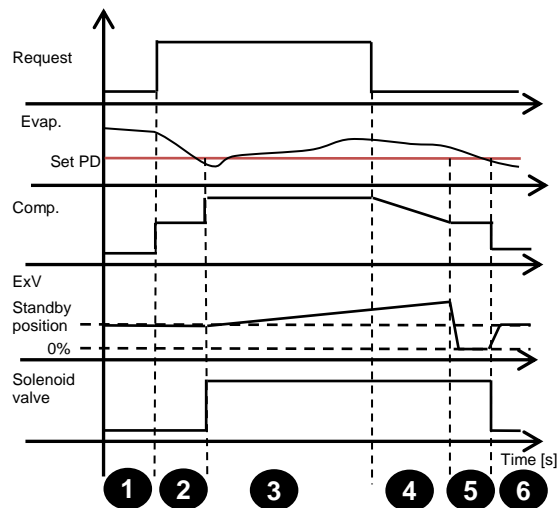

In the pump-down, there are 6 control phases:

	Comp.	ExV	Solenoid valve
1	OFF	Stand-by (open 25%)	OFF
2	Start-up + Pump-Down	Stand-by (open 25%)	OFF
3	Modulation	SH Control	ON
4	Shut-down	SH Control	ON
5	Minimum + Pump-Down	0%	ON
6	OFF	Stand-by (open 25%)	OFF

Note: When the selected EEV has an opening time greater than 3s, FLSTDmSCHE operates a small pre-opening of the valve before running the compressor in order to avoid to reach vacuum condition during startup procedure.

6.6 Compressor management

FLSTDmSCHE manages screw type compressors with step or stepless modulation. There can be a maximum of 2 screw compressors, each managing up to 4 modulation valves on the power control slide. The flow diagram below shows the process for calculating the request to the compressors:

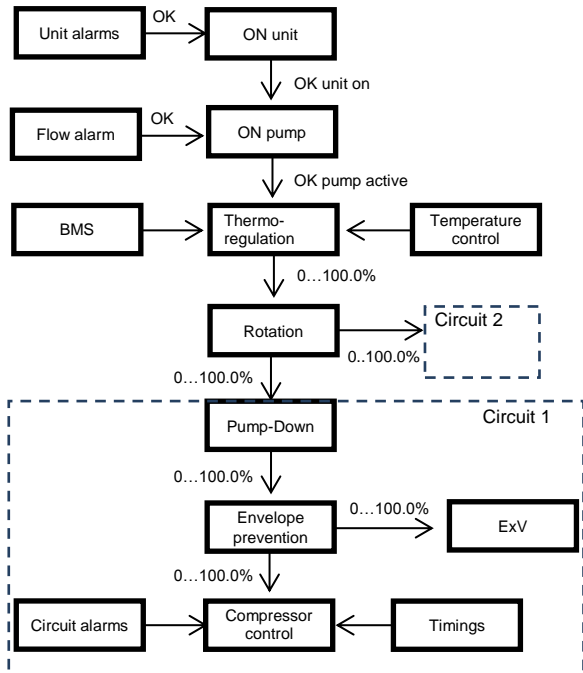

Note: For setup simplicity there are only parameters for one compressor and one circuit so all of the compressors and circuits in the unit will have the same settings.

6.6.1 Predefined compressors

In the compressor menu the type of compressor can be selected from the following list:

Compressor manufacturer	Compressor model	Gas	Manual version
Bitzer	CSH3	R134a	SH-170-4 i
		R407C	
	CSW	R134a	
		R407C	
CSVH	R134a	SP-160-2	
Hanbell	RC2	R134a	HBME-RC2-10-A(500)
RefComp	134-S /-XS	R134a	EA-03-04-E
Frascold	CXH	R134a	21-01-2014

	CXW	R134a	21-01-2014
	CXHIT	R134a	
	CXWIT	R134a	

The choice of a certain type of compressor sets the following parameters depending on the technical specifications of the compressor manufacturers:

- Valve data
 - Number of valves
 - Intermittent valve time
 - Impulse time for increase valves, for stepless modulation
 - Impulse time for decrease valves for stepless modulation
 - Valve behaviour during startup, control and shutdown.
- Step modulation compressor data:
 - Step number
 - Starting procedure duration
 - Shutdown procedure duration
 - Power of the various steps
 - Steps activation delay
 - Minimum safety time limits
- Stepless modulation compressor data:
 - First startup procedure phase duration
 - Second startup procedure phase duration
 - First shutdown procedure duration
 - Second shutdown procedure duration
 - Minimum power
 - Time to reach maximum power
 - Time to reach minimum power
 - Minimum safety time limits
- Compressor envelope:
 - All characteristics of the compressor envelope shape
 - Maximum discharge temperature
 - Minimum discharge temperature

If the CUSTOM compressor is set, all of these parameters (identified by code **Dbnn**) may be edited in the Compressor menu, otherwise they can only be displayed, without the possibility to change them.

6.6.2 Safety time control

FLSTDmSCHE ensures the compressor safety timings as:

- Minimum on time
- Minimum off time, after controlled shut down
- Minimum off time, after shut down due to alarm
- Minimum time for consecutive startups

These times are in the Compressor menu and can be changed by accessing with Service passord. The lower limit for changing the mentioned timings is pre-set according to the specifications of the compressor manufacturer. As described in the previous paragraph, these limits are set by default by the type of compressor and can be changed only after selecting a Custom type compressor.

6.6.3 Step modulation

FLSTDmSCHE manages the step modulation of the screw compressors: divides the percentage request generated by the thermoregulation between the various compressors depending on the rotation logic and controls the compressor steps according to the below described parameters.

Step number

This parameter (**Db53**) determines the number of steps that can be activated. These change according to the type of compressor.

Power of the various steps

Each step is characterized by a parameter (**Db54, Db55, Db56**) that specifies its power. This allows fine control of the power requested by the thermoregulation according to the effective power of each step of the compressor. If the cooling power of the machine is not consistent with the power expressed by the compressor, the CUSTOM compressor can be set and the parameters changed according to the needs of the machine.

Startup procedure duration

This parameter (**Db50**) specifies the duration of the compressor startup phase in which the valves have a preset behaviour to allow the compressor to reach the operating conditions.

Shutdown procedure duration

This parameter (**Db51**) specifies the duration of the compressor shutdown phase in which the valves have a preset behaviour to allow the compressor to reach the minimum power. Respecting this phase, on the next compressor startup, the slide will be at the minimum power and thus startup will be less heavy for the motor.

Step activation delay

To allow proper management of the compressor control slide, there are delays between the various steps in the power increase phase. These parameters (**Db57**, **Db58**, **Db59**) are dictated by the technical features of the compressors and are thus independent of the plant control.

To slow down the steps activation it is possible to set the parameter (**Da91**).

To slow down or speed up the activation or shut down of the compressors according to the temperature, the PID parameters and delays between the compressors must be changed in the Plant ad Compressor menus.

Step deactivation delay

To allow proper management of the compressor control slide, there are 20s fixed delays between the various steps in the power decrease phase. These delays are dictated by the technical features of the compressors and are thus independent of the plant control.

Valve management

FLSTdMScHE makes it possible to have different valve management depending on the compressor phase. The following controller phases exist:

1. Startup
2. Step 1
3. Step 2
4. Step 3 (if present)
5. Step 4 (if present)
6. Shutdown or compressor off

As previously described, the maximum number of valves is 4 (see digital outputs par.)

Control procedure

The previously described parameters make the compressor perform an activation procedure according to the compressor manufacturer's specifications. The graph below shows how the request from the control interacts with the control of the compressor during startup. In the example, the compressor has 3 steps of equal power (33%-66%-100%).

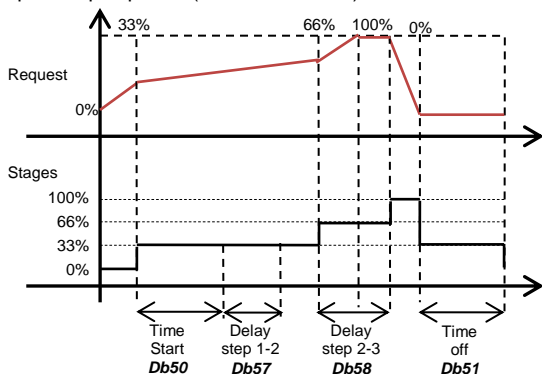

As shown in the graph, during the first phase the compressor is in startup and the regulation has no effect on it. Then, when the request is rising, the compressor must respect the activation times between the steps to avoid abrupt power changes that could damage the circuit and the compressor itself.

During the shutdown phase, which is hypothetically immediate in the graph, the delay between steps is not respected and the shutdown phase has started. If during the shutdown phase the request goes above the minimum, the compressor goes back to following the control phases.

6.6.4 Stepless modulation

FLSTdMScHE manages the stepless modulation of the screw compressors. The percentage request generated by the thermoregulation is divided between the various compressors depending on the rotation logic, then each compressor is modulated according to the parameters described below.

Minimum power

This parameter (**Db65**) expresses the minimum power percentage that the compressor can deliver. When the request reaches this value, the compressor can begin the startup phase.

First starting procedure phase duration

This parameter (**Db50**) specifies the duration of the compressor startup phase in which the valves have a preset behaviour to allow the compressor to reach the operating conditions.

Second starting procedure phase duration

(Parameter **Db61**). Some compressors have two startup phases with two distinct behaviours of the valves during those phases. The first phase is needed to bring the compressor to the minimum deliverable power (generally 25%) while the second phase is needed to bring the compressor to the power from which it can start to regulate (generally 50%).

First shutdown procedure duration

This parameter (**Db51**) expresses the time that the compressor uses to reach the minimum power in control (generally 50%). Respecting this phase, the compressor can turn off in ramp using the second shutdown phase.

Second shutdown procedure duration

This parameter (**Db63**) specifies the duration of the compressor shutdown phase in which the valves have a preset behaviour to allow the compressor to reach the minimum deliverable power (generally 25%). Respecting this phase, on the next compressor startup, the slide will be at the minimum power and thus startup will be less burdensome for the motor.

Time to reach maximum power

In screw compressors with stepless modulation the position of the slide cannot be defined through direct measurement thus the power delivered by the compressor must be estimated. For this reason, FLSTdMScHE implements a calculation logic for the power delivered by the compressor based on the time to reach the maximum power (**Db67**). This parameter indicates the time needed for the slide to move from the minimum power position to the maximum one (100%) keeping the charge valve active.

Since the valve is impulse controlled, the algorithm calculates the percentage of variation of the screw compressor capacity at each activation of the pulsating valve for increase. The valve will then continue to pulse until the percentage requested by the thermoregulation is reached (see following graph). Before re-activating the valve, the algorithm checks if activation could cause over delivery of the power and in this case the compressor goes into stand-by.

When the calculated power arrives at 100%, the stepless increase valve continues to load in order to keep the slide at the limit switch. Due to the number of activations resulting from management of the pulsating valves, the use of controllers with SSR relays is recommended (see digital outputs par.).

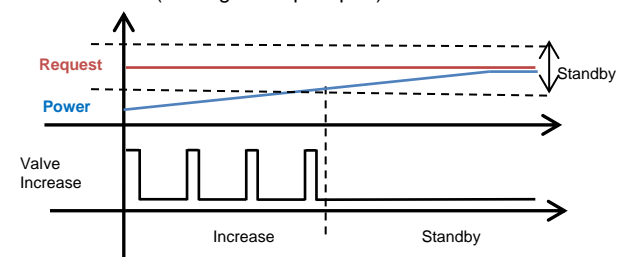

Time to reach minimum power

Along with the time to reach the maximum power, there is also the time to reach the minimum power (**Db66**). This parameter indicates the time needed at the slide to switch from the maximum power position (100%) to the minimum one, keeping the charge valve active. The time to reach the minimum power from reaching

the maximum power must be distinguished as some compressors use less time for the discharge phase.

Since the valve is impulse controlled, the algorithm calculates the percentage of variation of the screw compressor capacity at each activation of the pulsating valve for decrease. The valve will then continue to pulse until the percentage requested by the thermoregulation is reached (see following graph). Before re-activating the valve, the algorithm checks if activation could cause under delivery of the power and in this case the compressor goes into stand-by.

When the calculated power reaches the minimum, the stepless decrease valve continues to discharge to keep the slide in the minimum position. Due to the number of activations resulting from management of the pulsating valves, the use of controllers with SSR relays is recommended (see digital outputs par.).

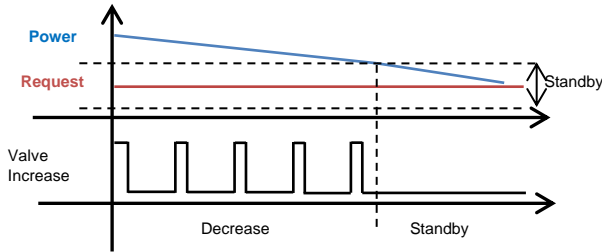

Pulsing valve management

As previously described, to increase or decrease the compressor capacity, the charge or discharge valves must be pulsed.

The parameters for managing these valves are as follows:

1. Increase valve impulse time (**Db02**)
2. Decrease valve impulse time (**Db03**)
3. Minimum valve rest time (**Da32**)
4. Maximum valve rest time (**Da33**).

The valve impulse times (**Db02**, **Db03**) are defined by the compressor model and are constant for the entire compressor control phase. These times can be set only with the CUSTOM compressor type.

The minimum and maximum rest times for the valves are parameters that can be changed in the Compressors menu. The rest time varies according to the distance of the percentage value requested from the power delivered.

The following is a rest time modulation example of the increase valve:

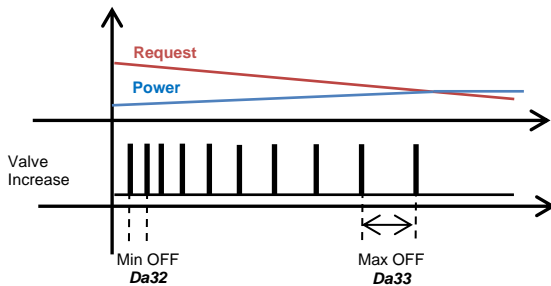

NB: If the absolute difference between Request and Power remains $\geq 30\%$, the duration of the activation of the valves to increase/decrease is multiplied by 2 after 20s, by 3 after 40s, by 4 after 60s. As soon as the difference drops below 30%, the value of the multiplier back to 1.

Valve management

FLSTDmSCHE makes it possible to have different valve management depending on the compressor phase. The controller phases are as follows:

1. First startup phase
2. Second startup phase
3. Increase power
4. Stand-by
5. Decrease power
6. First shutdown phase
7. Second shutdown phase or compressor off

As previously described, the maximum number of valves is 4 (see digital outputs par.).

Control procedure

The previously described parameters make the compressor perform an activation procedure according to the compressor manufacturer's specifications. The graph below shows how the regulation request interacts with the control of the compressor during startup. In the example, the compressor has a minimum power of 33%.

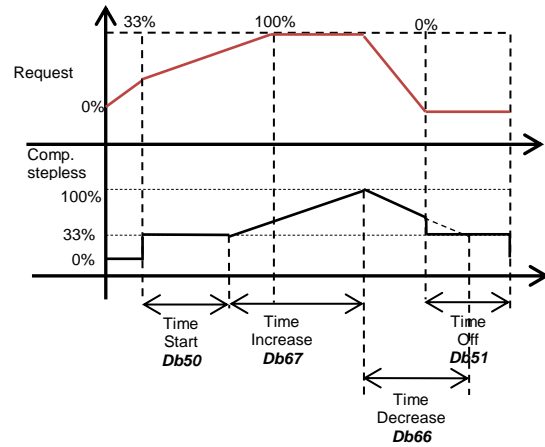

As shown in the graph, during the first phase the compressor is in startup and the control has no effect on it. Then, when the request is rising, the power of the circuit rises according to the activation times of the charge valve. If the request is faster than the movement of the slide, as we can see in the graph, the compressor will be delayed compared to the request.

During the shutting down phase, the compressor will proceed with the power decrease phase. If, as shown in the graph, the request decrease is immediate, the compressor will enter the shutting down phase without completely following the decrease phase. If during the shutdown phase the request goes above the minimum, the compressor goes back to following the modulation phases, aborting the shut-down.

6.6.5 Inverter modulation

FLSTDmSCHE manages the modulation of the screw compressors with integrated frequency inverter. The percentage request generated by the thermoregulation is divided between the various compressors depending on the rotation logic, then each compressor is modulated according to the parameters described below.

Minimum frequency

This parameter (**Dc06**) expresses the minimum frequency the inverter can deliver. When the request reaches this value, the compressor can begin the startup phase.

Maximum frequency

This parameter (**Dc07**) expresses the maximum frequency the inverter can deliver. It's the delivered frequency when the request reach 100%.

The following is an example of inverter compressor modulation:

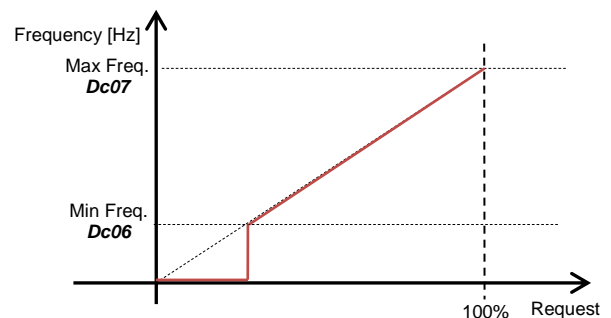

Note: Parameters **Dc06** and **Dc07** are needed for the correct operation of FLSTDmSCHE with 0-10V inverter control and without Modbus connection. It should be noted that in no case these parameters are able to modify the settings of the inverter.

Starting procedure phase duration

This parameter (**Db08**) expresses the duration of the compressor startup phase in which the compressor is kept at the minimum frequency.

Shutdown procedure duration

This parameter (**Db09**) expresses the duration of the compressor shutdown phase in which the the compressor is ramped down and kept at the minimum frequency before the shutoff.

6.6.6 Compressor motor startup

FLSTDmSCHE manages the following types of compressor motor startup:

1. Direct startup
2. Part-winding startup
3. Star-delta startup

Direct motor startup

The diagram showing the direct compressor startup is below:

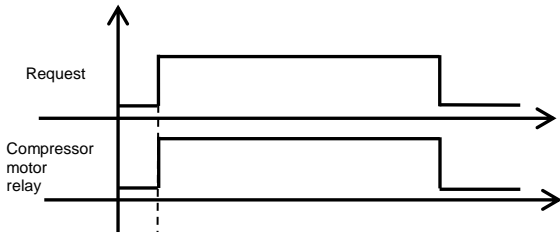

Part-winding motor startup

FLSTDmSCHE starts the compressor in part-winding mode. The diagram showing compressor motor startup in part-winding mode is below:

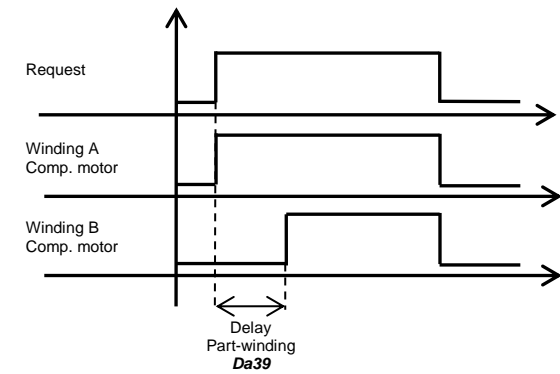

Below is the wiring diagram for connecting the motor with part-winding startup:

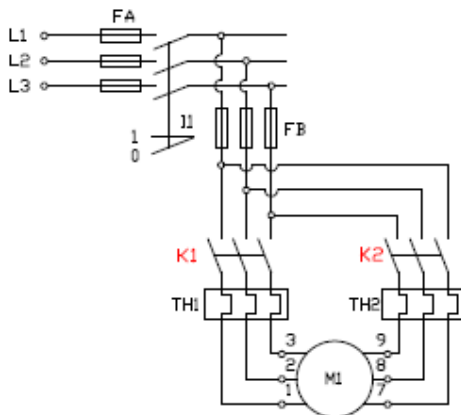

Note: The pCO5+ can manage startup relay activations for the compressor with a precision of 20 ms. Therefore set lower times is not recommended (for further information see the pCO5+ manual).

Star-delta motor startup

FLSTDmSCHE starts the compressor in star-delta mode by activating two digital outputs, increasing the activation safety. In the diagram shown, the activation of the KL line contact is indirect and controlled by the KS star contact during the first startup phase and then by the KT delta contact. Only these two are driven by the FLSTDmSCHE. Below is the wiring diagram for standard startup of the motor in star-delta mode:

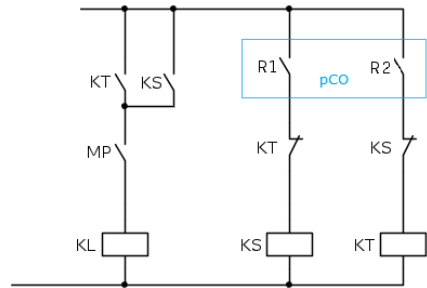

Legend:

- MP:** motor protections (HP and protection module)
- KL:** line contactor
- KS:** Star connection contactor
- KT:** Delta connection contactor
- R1-R2:** FLSTDmSCHE output relays

Below is the wiring diagram for connecting the motor:

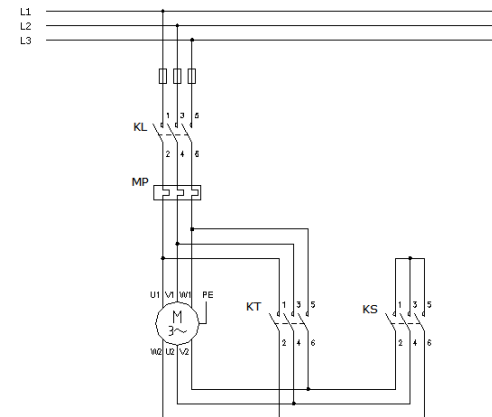

The activation sequence is as follows:

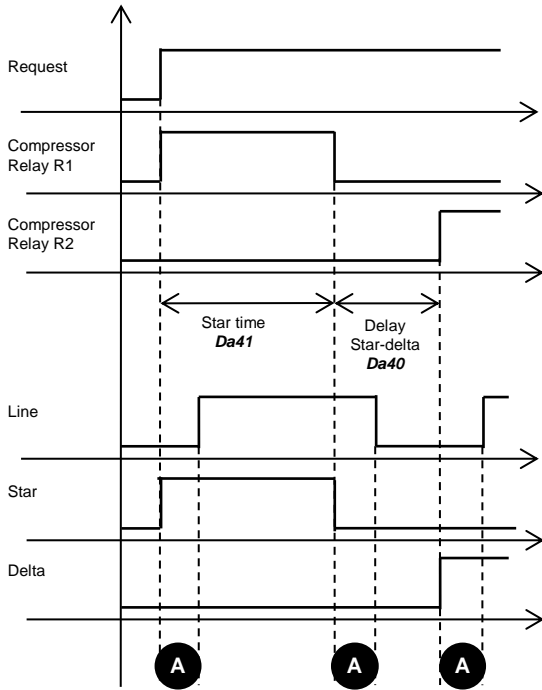

The indirect control technique for the line contactor allows double breaking of the arc during the first phase of the star-delta switch and thus shorter switching times.

In fact, the activation sequence for the auxiliary/main contacts is such that, when closing, first the main contacts (power) close and then the auxiliary ones while, when opening, first the auxiliary ones open and then the power contacts. This sequence ensures the participation of both star (KS) and line (KL) contactors to extinguish the arc which is thus distributed over a double distance in air, with reduced arc extinction times.

Given that the switch delay between the star and delta should be as short as possible (to prevent excessive slow down of the motor - reaching currents near startup direct during delta insertion) but at the same time ensuring arc extinction (to avoid even higher currents as a result of the short circuit due to the arc present in the centre of the star), since the proposed system reduces the arc extinction time it is possible to use significantly shorter times resulting in a more fluid startup. When setting the star-delta switching time, the mechanical delay time in closing the remote line switch must be considered. It is shown in the graph with A letter (~15ms): for example, if 25 ms is set, the overall time will be 40 ms.

6.7 Eco control and liquid injection

The controller manages two distinct digital outputs for controlling the Eco valve and the injection of liquid in the compressor. Both outputs are active only with the compressor on.

6.7.1 Eco valve

The Eco valve allows the cooling power to be increased and the compressor performance to be improved through a subcooling circuit or a two stage refrigerant expansion. Its efficiency is at a maximum especially with high condensing temperatures.

Thus the condensing temperature and the compressor power are controlled, as shown in the graph below:

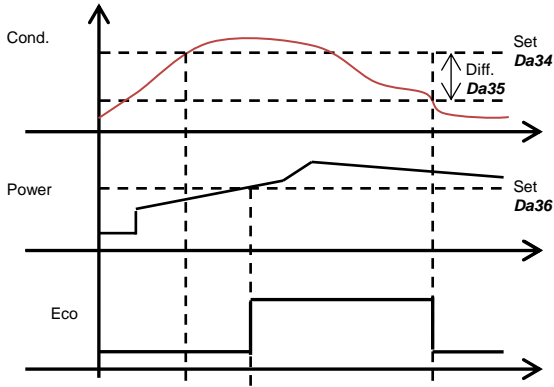

The Eco function is active if the following conditions are true:

1. The compressor is on for at least 300 seconds.
2. The condensing temperature is greater than the setpoint for the Eco (**Da34**);
3. The compressor power is greater than the minimum power specified for Eco operation (**Da36**);
4. The compressor is within the envelope operating limits regarding the high condensing temperature, high current and high evaporation temperature zones;
5. At least 300 seconds have passed since the previous deactivation of the Eco valve.

6.7.2 Liquid injection valve

The liquid injection valve cools the compressor during operation with high discharge temperatures and thus mainly in high condensation temperature and low evaporation temperature conditions (zone 2 of the envelope).

The discharge temperature is thus controlled and when it exceeds a threshold (**Da37**), the liquid injection valve is activated. In descent, as for the Eco valve, there is a differential (**Da38**) to avoid sudden startups and shutdowns.

6.8 Compressor protections

The operating limits (hereafter defined as envelope) of the screw compressors with step modulation or stepless modulation are controlled. This control cannot be disabled in order to prevent the compressor from working outside of the safety limits dictated by the manufacturer. All of the compressors inserted thus contain the envelope data.

Besides the operating limits specified by the manufacturer, there is the possibility of customizing the maximum condensation (**Da13**) and minimum evaporation (**Da12**) thresholds. These thresholds are considered only if they are more restrictive than the operating limits.

The envelope data for the previously listed compressors are preset but this data can be changed by setting a Custom compressor. The envelope data must then be entered according to the manufacturer's specification using the parameter codes shown in the table below.

The choice of a compressor with a type of gas is not binding in the choosing the refrigerant type. It is best to verify that the gas used has the same envelope as the gas indicated in the compressor parameter.

The description of the work zones of a generic envelope are shown below:

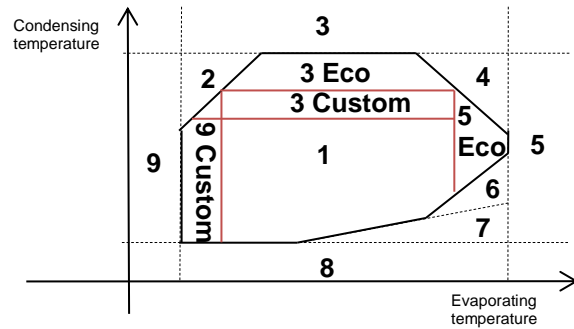

Zone	Par.	Description
1		Zone inside the operating limits (the prevention is active to avoid going outside the limits)
2	Db89 ⁽¹⁾ Db90 ⁽¹⁾ Db91 ⁽¹⁾ Db92 ⁽¹⁾	Max compression ratio
3	Db72 ⁽²⁾	Max condensation pressure
3 Eco	Db75 ⁽³⁾	Max condensation pressure with Eco active
3 Custom	Da13	Max condensation pressure custom threshold
4	Db77 ⁽¹⁾ Db78 ⁽¹⁾ Db79 ⁽¹⁾ Db80 ⁽¹⁾	Max motor current
5	Db74 ⁽²⁾	Max evaporation pressure
5 Eco	Db76 ⁽³⁾	Max evaporation pressure with Eco active
6	Db81 ⁽¹⁾ Db82 ⁽¹⁾ Db83 ⁽¹⁾ Db84 ⁽¹⁾	Min compression ratio
7	Db85 ⁽¹⁾ Db86 ⁽¹⁾ Db87 ⁽¹⁾ Db88 ⁽¹⁾	Min differential pressure
8	Db71 ⁽²⁾	Min condensation pressure
9	Db73 ⁽²⁾	Min evaporation pressure
9 Custom	Da12	Min evaporation pressure custom threshold

For each work zone outside the envelope, the alarm that turns off the compressor can be triggered with different delays that can be set in the Compressor menu.

The condensation high pressure limit is determined from the minimum between:

- the nominal compressor threshold (**Db72**),
- the threshold that can be set by Service (**Da13**),
- the nominal eco threshold if enabled (**Db75**).

The evaporation high pressure limit is determined from the minimum between:

- the nominal compressor threshold (**Db74**),
- the nominal eco threshold if enabled (**Db76**).

The evaporation low pressure limit for prevention is determined from the maximum of:

- the nominal compressor threshold (**Db73**),
- the threshold that can be set by Service (**Da12**),

Besides the operating limits dictated by the envelope shape, there is an operating limit on the discharge temperature (**Db99**), that turned off the compressor.

Notes:

- (1) With custom compressor, the control can be disabled by entering zero for both parameters;
- (2) With custom compressor, the primary envelope limits cannot be disabled.
- (3) With custom compressor, the Eco limits can be disabled if the values are set to less than or equal to zero.

6.9 Compressor alarm prevention

The suction and discharge pressures determine a working point and depending upon the zone, the control perform corrective actions to maintain or bring the compressor within the operating limits. These actions can be disabled through the prevention enabling parameter (**Da80**).

6.9.1 Prevention actions

The description of the work zones of a generic envelope are shown below:

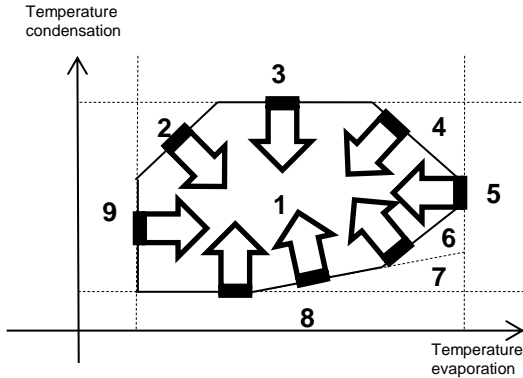

Zone	Description
1	Zone within operating limits
2	Prevention for high compression ratio
3	Prevention for high condensation pressure
4	Prevention for high motor current
5	Prevention for high evaporation pressure
6	Prevention for low compression ratio
7	Prevention for low differential pressure
8	Prevention for low condensation pressure
9	Prevention for low evaporation pressure

To allow the compressor to work inside the envelope, specific prevention actions are performed through the control of the compressor power, the speed of the condenser fans and the opening of the ExV.

In particular, the actions on the compressor power are:

- Decrease the speed for increasing/decreasing the power request coming from the thermoregulation (only for stepless compressors);
- Limit/increase the compressor power.

The action on the ExV valve is performed by varying the MOP threshold whose algorithm follows the set (evaporation temperature), decreasing the valve opening and thus reducing the mass capacity of the refrigerant and lowering the evaporation temperature.

The control actions on the power variation speed start when the working point is 7°C from the envelope border. These actions are only possible with stepless compressors.

In case of step compressor the only possible action on the compressor are to limit/increase its power, this is done when the working point cross the envelope border.

Below we examine the various prevention actions towards the operating limits.

Prevention for high compression ratio (zone 2)

The high compression ratio is a thermal limit of the compressor. Therefore, the "outside of the envelope" status is simply signalled without shutting down the compressor. As prevent action, compressor power is decreased. Since the critical conditions consists in high compressor discharge temperatures, the management of the compressor power directly controls the related probe.

To control the discharge temperature, a specific algorithm intervenes, initially slowing down the power increase until it stops when the control set is reached (5° C below the maximum limit). If the temperature increases further, the algorithm manages the power reduction gradually and slowly, imitating the behaviour of the thermal inertia of the compressor.

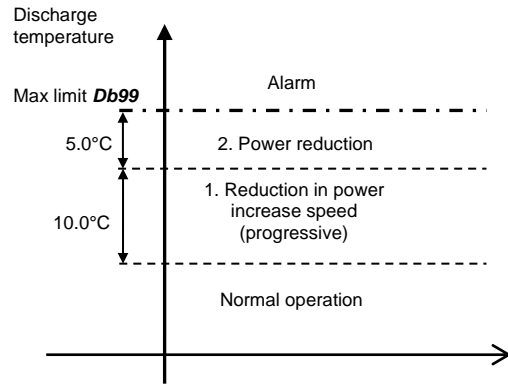

Device	Description
Compressor	1. Decrease of power increase speed 2. Power limitation
ExV	-
Fan	-

Prevention for high condensation pressure (zone 3)

Device	Description
Compressor	1. Decrease of power increase speed 2. Power limitation
ExV	-
Fan	-

Prevention for high motor current (zone 4)

Device	Description
Compressor	1. Decrease of power increase speed 2. Power limitation
ExV	MOP with specific algorithm
Fan	-

Prevention for high evaporation pressure (zone 5)

Device	Description
Compressor	Decrease of power decrease speed
ExV	MOP
Fan	-

Prevention for low differential pressure (zone 6)

Device	Description
Compressor	1. Decrease of power decrease speed 2. Power increase
ExV	Variable MOP
Fan	Condensation set point increase / evaporation set point decrease

Prevention for low compression ratio (zone 7)

Device	Description
Compressor	1. Decrease of power decrease speed 2. Power increase
ExV	Variable MOP
Fan	Condensation set point increase / evaporation set point decrease

Prevention for low condensation pressure (zone 8)

Device	Description
Compressor	1. Decrease of power decrease speed 2. Power increase
ExV	-
Fan	-

Prevention for low evaporation pressure (zone 9)

The evaporation low pressure limit for prevention is determined from the maximum between:

- the nominal compressor threshold (**Db73**),
- the threshold eventually set by Service (**Da12**),

- the antifreeze limit according to the mode (**A028** in cold and **C037** in hot with water/water unit).

Device	Description
Compressor	1. Decrease of power increase speed 2. Power limitation
ExV	-
Fan	-

6.10 Compressor alarms management

Controlled compressor shutdown

The control algorithm calls for two types of compressor shutdown depending on severity:

- Immediate compressor shutdown;
- Controlled compressor shutdown.

Immediate compressor shutdown is activated in the event of critical alarms and alarms that require direct intervention on the compressor contactor coil (see alarms table for details). Immediate compressor shutdown requires a greater amount of time to reset the slide position, which can be defined through the specific parameter (**Da06**).

Controlled compressor shutdown is activated for all alarm conditions that are not an immediate danger and thus allow shutdown of the compressor itself using the correct procedure (immediate shutdown should be kept to a minimum). This procedure limits the presence of liquid and ensures less resistant torque at the next compressor startup.

Controlled shutdown simultaneously activates the shut-down procedure (continuous activation of the discharge valve for the shutdown time - **Db51**) and the pumpdown (if enabled). The procedure is finished when the first of the two actions is completed.

The compressor will be available again as soon as the minimum nominal off time has passed (**Da05**).

Startup-Running delay of the compressor

Compressor startup is a critical phase and for this reason FLSTDmSCHE has differentiated control for certain alarms to exceed the transition phase from compressor startup and allow it to reach operating condition. The alarms that use this characteristic are the following:

- Low pressure from pressure switch alarm
- Oil level alarm
- High evaporation pressure alarm
- Low pressure ratio alarm
- Low pressure delta alarm
- Low condensation pressure alarm
- Low evaporation pressure alarm

There are two types of delays for these alarms:

- Startup delay
- Running delay

The alarm condition is ignored with the compressor off and during startup. Once the startup phase is complete, the operation phase is entered and the alarm is triggered when the delay is exceeded.

It will behave as follows:

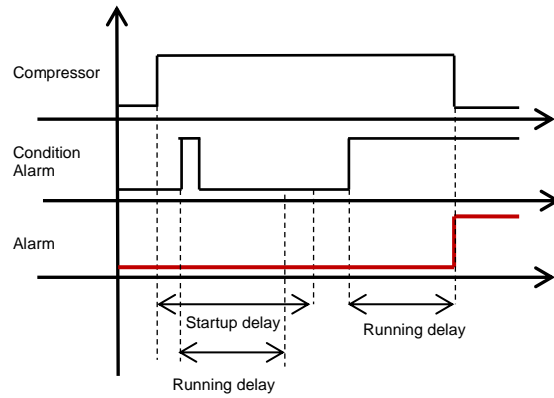

6.11 EVD EVO device

The EVD EVO driver for the electronic expansion valve is a fundamental device in the FLSTDmSCHE controller. It allows safe management of the compressor and circuit and reads all of the essential probes for regulating suction superheat, managing the work zone and the discharge temperature.

For each pCO5+ board, up to two single type drivers are controlled, each managing one circuit.

The driver and controller communicate using the CAREL protocol with a serial speed of 19200bps on the FB2 serial port of the pCO.

6.11.1 FLSTDmSCHE logic for ExV control

The FLSTDmSCHE controller does the following:

- Manages communication with the EVD EVO drive (reading and send parameters via serial port);
- Completely displays the EVD parameters in the Exv menu, divided by type of regulation;
- Sends the cooling capacity of the compressor to the driver.

If the driver is offline, the compressor in the circuit involved will be immediately turned off without the shutdown procedure.

Control parameter management

The controller differentiates the parameters between the various driver control statuses:

- Control in chiller mode;
- Control in heat pump mode.

Therefore for all control parameters there is a series for chiller mode and a series for heat pump mode.

The following are the parameters that are differentiated according to the operating mode:

- Superheat parameters (Setpoint and PID);
- Alarm thresholds and integral actions for LOP, MOP and Low SH alarms.

6.11.2 EVD EVO logic for ExV control

The driver does the following:

- Valve activation;
- Suction superheat control;
- Alarm and low superheat control (Low SH);
- Alarm and minimum evaporation temperature control (LOP);
- Alarm and maximum evaporation temperature control (MOP);
- Alarm and high condensation temperature control (HighTCond);
- Control of the cooling capacity sent from the controller, that sets the valve position according to the compressor control status.



Notes: For further information see the Individual EVD EVO manual code +0300005IT.

6.12 Condenser pump

FLSTDmSCHE manages up to two condenser side pumps (only for water/water units). The condenser side pump group is unique and can be made up of one or two pumps.

As in the evaporator pump management, the condenser pumps are activated with the unit on and a delay can be set (**C012**) for shutting down the pump from the last compressor shut down.

FLSTDmSCHE has the following functions:

- With two pumps, automatic alternating between the pumps to ensure the circulation of the fluid and equalize the hours of operation. Automatic alternation is generated:
 - After a period of time that can be set in hours (**C013**).
 - With pump overload active.
- Management of the pump overload. Signalling of the anomaly and immediate shutdown of the pump.
- Management of the flow switch that controls the circulation of the fluid in the system.
- Management of the antifreeze with the unit off by means of startup of the pump to activate the circulation of the fluid (with the unit on, the function is disabled).

6.13 Condenser fans

With two or more circuits, FLSTDmSCHE manages the condensation separated (independent air circuits) or the presence of a common air circuit, by setting the parameter **C048**.

In case of common air circuit, fan 1 works with the highest request between circuit 1 and 2, whereas fan 3 works with the highest request between circuit 3 and 4.

The table below summarizes the probes used for fan control in each machine configuration:

Circuits	Probes used for control	
	Chiller	Heat pump
1	Condensing pressure circuit 1	Evaporating pressure circuit 1
2	Condensing pressure circuit 2	Evaporating pressure circuit 2
3	Condensing pressure circuit 3	Evaporating pressure circuit 3
4	Condensing pressure circuit 4	Evaporating pressure circuit 4

FLSTDmSCHE manages the inputs dedicated to signalling the fan overload: these inputs don't stop the circuit. The prevention of pressure conditions and the related alarms will slow down or stop the compressors.

The control mode changes with the operation mode (chiller or heat pump).

FLSTDmSCHE manages for each circuit either an analog and a digital outputs in the case of modulating fans (with inverter) or up to 3 digital outputs in the case of ON-OFF fan.

6.13.1 Modulating fans

This configuration is enabled by setting a single fan per circuit **C075**.

The digital output can be used to enable fan inverter or it can be configured as an On/Off auxiliary fan through the parameter **C046**. Below we can see the difference in the command with an example in chiller control:

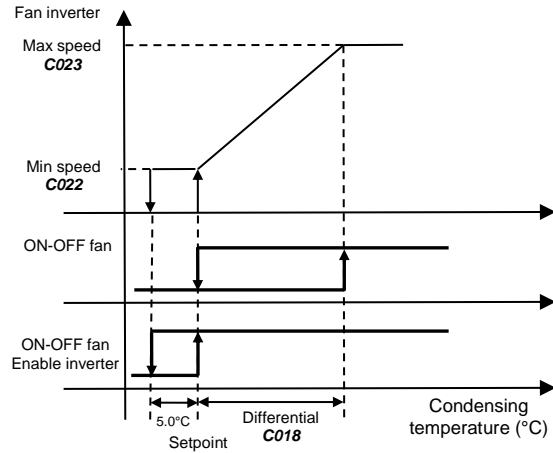

6.13.2 ON-OFF fans

This configuration is enabled by setting more than one fan per circuit **C075** and properly setting **C046**.

The single fan differential (Chiller: **C073**; heatpump: **C074**) is set as a percentage of the regulation differential. This makes the regulation more flexible and allows to overlay the hysteresis activation of individual fans. A fixed 10 second delay between steps prevent that for inertia more than needed steps will be inserted or disinserted.

Below we can see an example of 3 ON-OFF fans with individual differential equal to 50% of regulation differential, in chiller control:

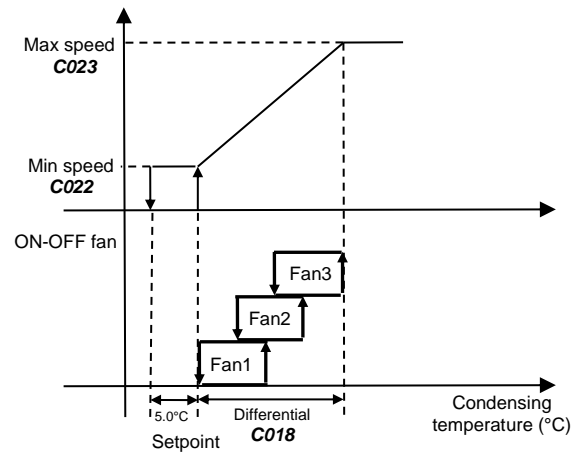

6.13.3 Control in chiller mode

Fan control can be modulating or ON-OFF and controls the saturated temperature value equivalent to the condensing pressure.

The control diagram is below:

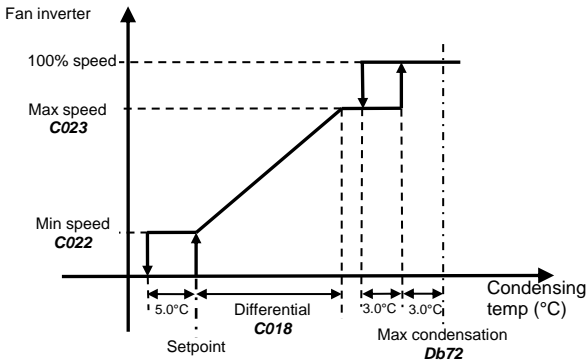

In the graph, some offsets are given a numeric value, that indicates that they cannot be changed from the display; they are fixed.

The fan control setpoint is related to the minimum condensation value of the envelope plus an offset (C015). The display shows the calculated setpoint value (limit + offset).

Setpoint control

To optimize envelope control and compressor efficiency, setpoint is increased by adding a correction when the compressor operation point approaches the limit of zone 6 or zone 7 of the envelope (see diagram below), within 5°C of the vertical projection on the limit. Within this zone the setpoint increases at 1.2°C per min. If the compressor operation point goes outside the envelope in zone 6 or 7, the correction increases at 3.6°C per min. As soon as the operation point returns above the specified increase zone, any correction decreases at 1.2°C per min. until it is reset.

If the envelope prevent is not enabled, a fixed setpoint can be set (C014).

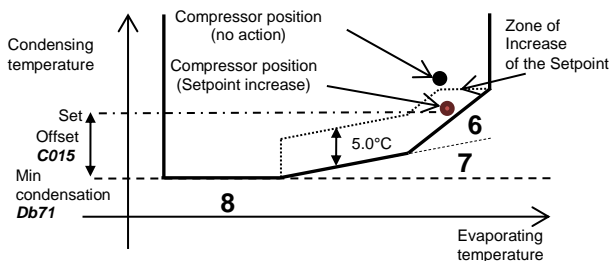

In chiller mode, it can be set a specific condensation setpoint (C016) for compressor startup, of higher value, so that compressor can quickly reach operating condition.

Switching to the nominal setpoint is done gradually in the time (C017), according to the diagram below:

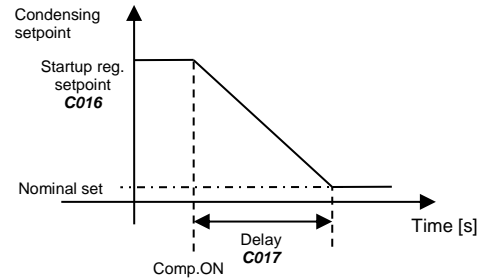

6.13.4 Control in heat pump mode

Fan control can be modulating or ON-OFF and controls the saturated temperature value equivalent to the evaporating pressure.

The control diagram is below:

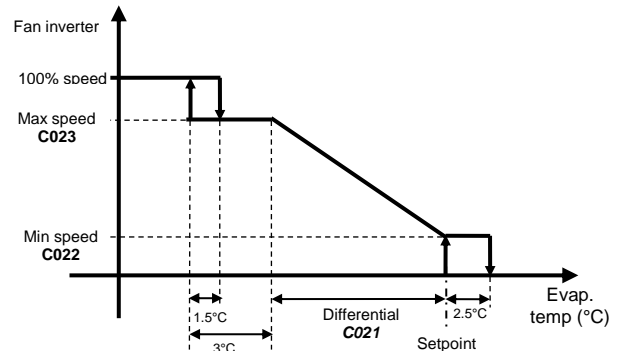

In the graph, some offsets are given a numeric value, indicating they cannot be modified from the display but are fixed.

The fan control setpoint is related to the maximum evaporation value of the envelope minus an offset (C020). The display shows the calculated setpoint value (limit - offset).

Setpoint control

To optimize envelope control and compressor efficiency, the value is increased by adding a correction when the compressor operation point approaches the limit of zone 6 or zone 7 of the envelope (see diagram below), within 3°C of the horizontal projection on the limit. Within this zone the setpoint decreases at 1.2°C per min. If the compressor operation point goes outside the envelope in zone 6 or 7, the correction decreases at 3.6°C per min. As soon as the operation point returns above the specified increase zone, any correction increases at 1.2°C per min. until it is reset.

If the envelope is not enabled, a fixed setpoint can be set (C019).

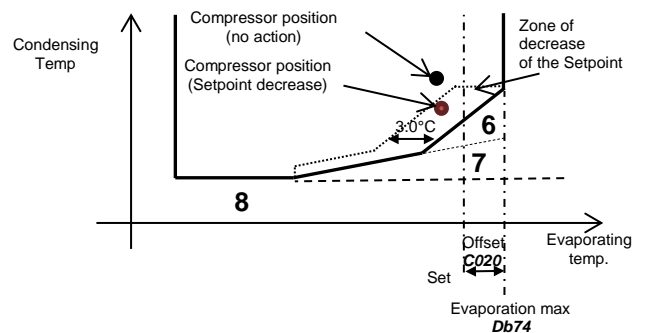

6.14 Free-Cooling

The Free-Cooling (FC) function can be enabled (parameter **A044**) on air-water unit, Chiller only, provided with air to water heat exchanger coils upstream of the condenser coils and modulating control of the fans. When the outside air temperature is low enough to cool the water that enters into the unit, Free-Cooling is enabled, the water undergoes a cooling from outside air before entering the evaporator.

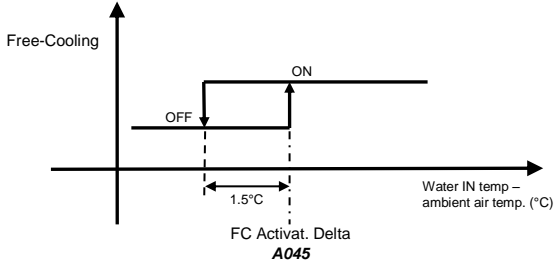

The ventilation is controlled by the condensing value as long as the circuit compressor is active; as soon as the compressor shuts down the ventilation follows the request of the thermostatic regulation.

6.14.1 Dynamic gain of FC regulation

This particular function allows to manage the balancing of capacity between Free-cooling battery and evaporator: this optimization offers best performance in terms of regulation stability and smoothness.

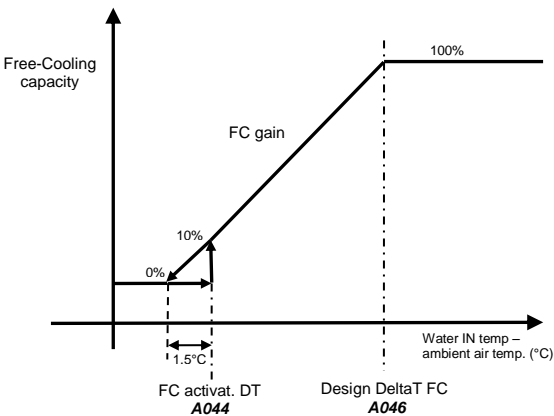
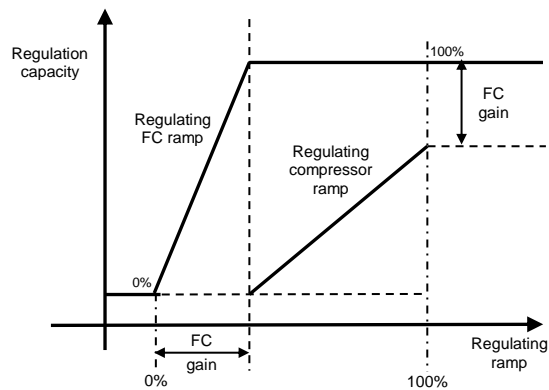

Diagram shows the ideal behaviour of FC regulation gain related proportionally to its capacity; "Design DeltaT FC" is the value of temperature difference (water inlet - ambient) that is needed to cover the nominal capacity of the unit, using free-cooling coils only. The "FC gain" obtained value is used to adapt the assignment of regulation ramp to the different sources of cooling, as shown on following diagram.



The result is a perfect balancing between the capacity of FC coils and evaporator, so that to maintain the same proportionality in each "capacity working point", that is same reaction to same temperature variation with regardless to the load percentage.

6.14.2 FC efficacy control

This control allows FLSTDmSCHE to start the compressors when the sole use of free cooling coil fails to bring water to the setpoint despite external conditions allow operation in full FC. When this happens it is possible that some malfunction in the free cooling device are present and therefore it is necessary to start the compressors and disable the FC in order to ensure operation of the unit. The anomaly is signaled by the alarm code 204.

6.15 Defrost

During heat pump operating in air/water units, the external exchanger (coil) works as an evaporator. If the outside temperature is low, frost may form on the coil itself, resulting in a reduction in machine efficiency. In this case, it is best to activate the defrost function to free the exchanger of frost and reset the machine to maximum efficiency conditions.

Activation of defrost depends on the value of the reference sensor (pressure transducer, low pressure side) and any delay (**C030**) from when the activation threshold (**C024**) was exceeded as shown in the figure below:

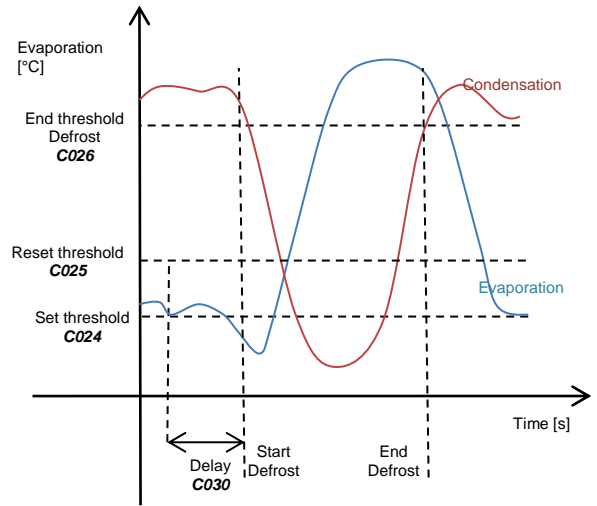

If during defrost delay the low pressure value does not exceed the reset threshold, the procedure will start. Defrost ends when the reference sensor (pressure transducer, high pressure side) exceeds the end defrost threshold.

6.15.1 Defrost procedure

The figure below shows how the various components of the circuit and defrost phases are managed.

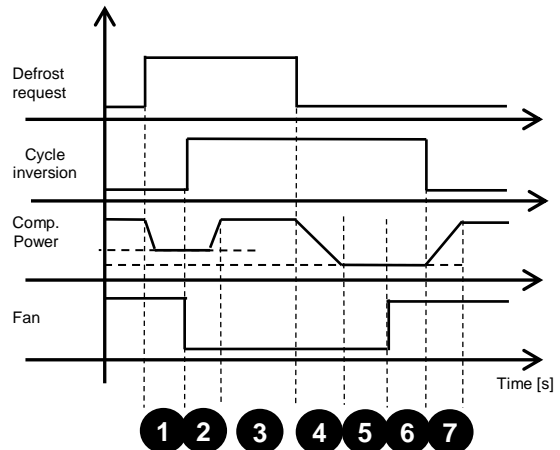

The description of the control phases follows:

Check defrost entry (1)

Once defrost start condition is verified according to the criteria previously described, there is a parameter (**C030**) to delay the entry of the circuit in the defrost phase.

Compressor decrease in defrost entry (2)

In this phase the compressor decreases its power to reach the set defrost entry percentage (**C028**), during the fridge cycle inversion phase. This procedure has a minimum duration that is half the inversion time (**C027**). If during this time the compressor has not reached the set point, for example for stepless compressors that need more time in order to reach a certain power, the time is then increased.

If the set point during the cycle inversion procedure is set at 0%, the compressor will proceed with the shutdown phase and shut down. The compressor safety times are respected.

If the cycle inversion time is set to zero, the phase will only last for the amount of time needed to bring the compressor to the input setting for the defrost procedure.

The other circuit control devices, such as cycle inversion valve and fans, continue to regulate in heat pump mode.

Compressor increase in defrost entry (3)

The 4-way valve is positioned in chiller mode to perform the defrost. The fans shut off and the compressor starts to increase its power to reach the 100% fixed set point during defrost. The duration of the phase depends on the cycle inversion time (**C027**) and the time needed for the compressor to turn on if it was off.

During the defrost phase, the fans remain off and can only switch on to avoid the condensation temperature exceeds the high pressure threshold.

Defrost phase (4)

Real defrosting starts in phase 4 where the compressor delivers full power to defrost the external coil.

The minimum defrost time, maximum defrost time and time between two defrost cycles are activated in this phase.

The minimum time in defrost is necessary to prevent the defrost cycle from not lasting long enough, performing a partial defrost of the exchanger.

The maximum defrost time is necessary to prevent the defrost procedure from lasting too long, blocking the production of hot water required by the utilities.

The time between two defrost cycles is needed to keep the unit from entering defrost too often and to allow the machine to partly satisfy the request.

The defrost phase stops for the previously described pressure conditions and time. If the compressor shuts off during the phase, the timers are reset and the circuit remains in the defrost cycle until the compressor starts again and completes it.

Compressor decrease in defrost outgoing (5)

This procedure has a minimum duration that is half the inversion time. If during this time the compressor has not reached the set point, for example for stepless compressors that need more time in order to reach a certain power, the time is then increased.

If the set point during the cycle inversion procedure is set at 0%, the compressor will proceed with the shutdown phase and shut down.

The compressor safety times are respected. If the cycle inversion time is set to zero, the phase will only last for the amount of time needed to bring the compressor to the output setting for the defrost procedure.

In this phase the fan is off and activated only to prevent high pressure and the cycle inversion valve stays in chiller mode.

Drip phase (6)

In this phase the fan is off and activated only to prevent high pressure. The compressors go to defrost outgoing power. We recommend turning the compressor off during this phase and allowing the defrost to complete by thermal inertia. In fact, with the

fans off, the heat that was just developed is not immediately dissipated. If the compressors are left on, the defrost phase is prolonged unnecessarily.

The duration of the drip phase can be set (parameter **C033**). With the time at zero, no phase is performed.

Post-drip phase (7)

During this phase, the compressors remain at the defrost outgoing power. The fans are turned on and forced to 100% to completely expel the water that is still on the coil.

The duration of the post-drip phase can be set (parameter **C034**). With the time at zero, no phase is performed.

Compressor increase in defrost outgoing (5)

The circuit starts regulating according to normal operation in heat pump mode.



Note: during defrost, any setting of the pump-down function is ignored.

6.15.2 Defrost synchronization

When there are several circuits the defrost behaviour can be synchronized.

Independent defrost

The various circuits enter defrosting when the conditions exist, independent from each other. In this manner, there is no synchronization and the circuits can perform defrosting at the same time.

Separate defrosting

The first circuit that requests defrosting enters the phase while the others continue to work in heat pump mode or stop if they are also in defrost mode to prevent frost.

When the first circuit has finished defrosting, the others are then free to perform this phase.

Simultaneous defrost

This procedure is used when condenser coil air flow of a circuit influences the other: during the defrost phase it means a significant use of energy to recover the heat dispersed by the air flow in the other circuit.

In this mode, the first circuit that requests it brings the entire unit into defrosting.

If only one circuit enters defrost it will complete all phases while the other is off. If the others are inside the defrost start hysteresis but are waiting the start delay, this last is ignored and this circuit also starts defrosting.

When one of the circuits reaches the end defrost condition, it will stay in dripping phase to wait until the other circuit completes the procedure.

In this manner, dripping is performed by both, thus preventing the flow of air from the condensing exchanger from influencing the defrost phase.

During this phase, the compressor is turned off rather than follow the compressor power in output, to prevent the delay from the other compressor from bringing the utilities to temperatures that are too low.



Note: In case condensation with common air circuit, the simultaneous defrost is automatically enabled.

6.16 4-way valve control

A special management to assure the correct control of the 4way valve has been implemented. When a request of valve reverse is present, the application check if the pressure delta is higher than a threshold (**Da2A**) to command the valve: if the pressure delta is lower, the application waits until the compressor is switched ON and reverse the valve when the DP conditions are met.

In case of blackout the application assure the realignment of the 4way valve status with the physical valve position at the next startup. This is done considering the circuit status before the blackout.

6.17 Test functions

There are some advanced functions that allow easier commissioning and testing of the unit in the factory or on field.

6.17.1 Manual management

In the individual device menu the individual actuators on the machine can be switched from automatic to manual.

For digital outputs, the possible states are ON or OFF while for analogue outputs the selection can vary from 0-100%. All defaults are in Auto. This selection bypasses the control but not the alarm thresholds set to protect the safety of the machine. In general, this function is adopted to test the individual actuators during installation.

The manual operation characteristics of the devices are shown below:

Devices	Notes
Compressors	Safety times followed All compressor alarms are considered
Liquid solenoid	-
Evaporator pump	Pump overload and active flow alarm
Condenser pump	Pump overload and active flow alarm
Defrost	-
Condenser fans	Speed-up disabled
Antifreeze heaters	-
ExV	ExV alarms all disabled

6.17.2 I/O test

In the HW/SW menu there is a submenu for verifying the electrical connection of the digital outputs in the panel, forcing the status of the outputs to manual control.



Attention: The I/O test fast is done strictly empty, without activating the power organs (compressors, pumps, fans, etc.) that are previously removed from power: during this phase ALL safety systems are disabled.



Note: the I/O test status is not saved so after turning the controller power supply off and on, FLSTDmSCHE goes back to automatic mode.

7. PARAMETERS TABLE

The following table shows the parameters and values displayed by the terminal.

7.1 Info

The info menu shows all the states of the various devices. No value is accessible in read / write.

Parameter code	PWD	Description	Default	UOM	Range	Type	R/W	BMS index
---	---	Rotation request compressor 1 circuit 1	0	%	0...999	I	R	223
---	---	Compressor 1 circuit 1 power status	0	---	0: Get 1: Wait 2: Man 3: Rot 4: Defr 5: PmpD 6: Off 7: Prev	I	R	6
---	---	Compressor 1 running power circuit 1	0	%	0...999	I	R	1
---	---	Envelope working point circuit 1	0	---	0: - 1: Z1:Ok 2: Z2:HiDP 3: Z3:HiDscgP 4: Z4:HiCurr 5: Z5:HiSuctP 6: Z6:LoDP 7: Z7:LoPRat 8: Z8:LoDscgP 9: Z9:LoSuctP	I	R	9
---	---	Discharge temperature circuit 1	0.0	°C/°F	-999.9...999.9	A	R	53
---	---	Discharge pressure circuit 1	0.0	barg/psig	-999.9...999.9	A	R	45
---	---	Condensing temperature circuit 1	0.0	°C/°F	-999.9...999.9	A	R	49
---	---	Compressor 1 device available status circuit 1	0	---	0: Off 1: --- 2: On 3: --- 4: --- 5: --- 6: Force Off 7: --- 8: --- 9: --- 10: Alarm 11: Off 12: On 13: Man 14: PumpDown 15: ---	I	R	13
---	---	Compressor 1 circuit 1 On/Off countdown	0	s	0...999	I	R	
---	---	Compressor 1 running phase circuit 1 (STEP configuration)	0	---	0: --- 1: Start up 2: --- 3: Step 1 4: Step 2 5: Step 3 6: Step 4 7: Shutting Off 8: ---	I	R	222
---	---	Compressor 1 running phase circuit 1 (STEPLESS configuration)	0	---	0: --- 1: StartUp 2: StarUp incr. 3: Increase 4: Hold 5: Decrease 6: Fast decrease 7: ShutOff decr. 8: ShutOff	I	R	222
---	---	Compressor 1 running phase circuit 1 (INVERTER configuration)	0	---	0: --- 1: StartUp 2: --- 3: Running 4: Running 5: Running 6: Running 7: ShutOff 8: ---	I	R	222
---	---	Inverter frequency compressor 1 circuit 1	0.0	---	0.0...999.9	A	R	1
---	---	Compressor 1 phase countdown circuit 1	0	s	0...999	I	R	
---	---	Suction temperature circuit 1	0.0	°C/°F	-999.9...999.9	A	R	41
---	---	Suction pressure circuit 1	0.0	barg/psig	-999.9...999.9	A	R	33
---	---	Evaporation temperature circuit 1	0.0	°C/°F	-999.9...999.9	A	R	37
---	---	External temperature	0.0	°C/°F	-999.9...999.9	A	R	57
---	---	Condenser fan pressure probe value circuit 1	2.0	barg/psig	0.0...999.9	A	R	224
---	---	Condenser fan temperature probe value circuit 1	13.0	°C/°F	0.0...999.9	A	R	228
---	---	Number of defrost phase actually running circuit 1	0	---	0 1: Defr.: check 2: Defr.: off sim.synch 3: Defr.: decr.comp.in 4: Defr.: incr.comp.100% 5: Defr.: running 6: Defr.: decr.comp.out 7: Defr.: dripping 8: Defr.: post-dripping	I	R	287
---	---	Condenser fan setpoint circuit 1	13.0	°C/°F	0.0...999.9	A	R	6
---	---	Condenser fan 1 output request circuit 1	13.0	%	0.0...999.9	A	R	9
---	---	Condenser fan circuit 1 in manual mode	0	---	0 1: Man	D	R	

Parameter code	PWD	Description	Default	UOM	Range	Type	R/W	BMS index
---	---	Valve opening percent circuit 1	0.0	---	0.0...999.0	A	R	21
---	---	Discharge Superheat circuit 1	0.0	°C/°F	-3276.8...3276.7	A	R	14
B001	---	Manual positioning enable - Circ1	0	---	0 1: Man	D	R	554
---	---	EVD status circuit 1	0	---	0: --- 1: Close 2: Close 3: Std-by 4: Pos 5: Pos 6: Wait 7: On 8: On 9: On 10: On 11: On 12: On 13: On 14: Init 15: On 16: Pos 17: Pos	I	R	
---	---	EEV position circuit 1	0	---	0...9999	I	R	17
---	---	Superheat circuit 1	0.0	°C/°F	-3276.8...3276.7	A	R	18
---	---	Rotation request compressor 1 circuit 2	0	%	0...999	I	R	234
---	---	Compressor 1 circuit 2 power status	0	---	0: Get 1: Wait 2: Man 3: Rot 4: Defr 5: PmpD 6: Off 7: Prev	I	R	5
---	---	Compressor 1 running power circuit 2	0	%	0...999	I	R	2
---	---	Envelope working point circuit 2	0	---	0: - 1: Z1:Ok 2: Z2:HiDP 3: Z3:HiDscgP 4: Z4:HiCurr 5: Z5:HiSuctP 6: Z6:LoDP 7: Z7:LoPRat 8: Z8:LoDscgP 9: Z9:LoSuctP	I	R	10
---	---	Discharge temperature circuit 2	0.0	°C/°F	-999.9...999.9	A	R	54
---	---	Discharge pressure circuit 2	0.0	barg/psig	-999.9...999.9	A	R	46
---	---	Condensing temperature circuit 2	0.0	°C/°F	-999.9...999.9	A	R	50
---	---	Compressor 1 device available status circuit 2	0	---	0: Off 1: --- 2: On 3: --- 4: --- 5: --- 6: Force Off 7: --- 8: --- 9: --- 10: Alarm 11: Off 12: On 13: Man 14: PumpDown 15: ---	I	R	14
---	---	Compressor 1 circuit 2 On/Off countdown	0	s	0...999	I	R	
---	---	Compressor 1 running phase circuit 2 (STEP configuration)	0	%	0: --- 1: Start up 2: --- 3: Step 1 4: Step 2 5: Step 3 6: Step 4 7: Shutting Off 8: ---	I	R	233
---	---	Compressor 1 running phase circuit 2 (STEPLESS configuration)	0	%	0: --- 1: StartUp 2: StarUp incr. 3: Increase 4: Hold 5: Decrease 6: Fast decrease 7: ShutOff decr. 8: ShutOff	I	R	233
---	---	Compressor 1 running phase circuit 2 (INVERTER configuration)	0	%	0: --- 1: StartUp 2: --- 3: Running 4: Running 5: Running 6: Running 7: ShutOff 8: ---	I	R	233
---	---	Inverter frequency compressor 1 circuit 2	0.0	---	0.0...999.9	A	R	2
---	---	Compressor 1 phase countdown circuit 2	0	s	0...999	I	R	
---	---	Suction temperature circuit 2	0.0	°C/°F	-999.9...999.9	A	R	42
---	---	Suction pressure circuit 2	0.0	barg/psig	-999.9...999.9	A	R	34
---	---	Evaporation temperature circuit 2	0.0	°C/°F	-999.9...999.9	A	R	38
---	---	External temperature	0.0	°C/°F	-999.9...999.9	A	R	57
---	---	Condenser fan pressure probe value circuit 2	2.0	barg/psig	0.0...999.9	A	R	225

Parameter code	PWD	Description	Default	UOM	Range	Type	R/W	BMS index
---	---	Condenser fan temperature probe value circuit 2	13.0	°C/°F	0.0...999.9	A	R	229
---	---	Number of defrost phase actually running circuit 2	0	---	0 1: Defr.: check 2: Defr.: off sim.synch 3: Defr.: decr.comp.in 4: Defr.: incr.comp.100% 5: Defr.: running 6: Defr.: decr.comp.out 7: Defr.: dripping 8: Defr.: post-dripping	I	R	288
---	---	Condenser fan setpoint circuit 2	13.0	°C/°F	0.0...999.9	A	R	5
---	---	Condenser fan output request circuit 2	13.0	%	0.0...999.9	A	R	10
---	---	Condenser fan circuit 2 in manual mode	0	---	0 1: Man	D	R	
---	---	Valve opening percent circuit 2	0.0	---	0.0...999.0	A	R	22
---	---	Discharge Superheat circuit 2	0.0	°C/°F	-3276.8...3276.7	A	R	13
B003	---	Manual positioning enable - Circ2	0	---	0 1: Man	D	R	557
---	---	EVD status circuit 2	0	---	0: --- 1: Close 2: Close 3: Std-by 4: Pos 5: Pos 6: Wait 7: On 8: On 9: On 10: On 11: On 12: On 13: On 14: Init 15: On 16: Pos 17: Pos	I	R	
---	---	EEV position circuito 2	0	---	0...9999	I	R	18
---	---	Superheat circuit 2	0.0	°C/°F	-3276.8...3276.7	A	R	17
---	---	Rotation request compressor 1 circuit 3	0	%	0...999	I	R	245
---	---	Compressor 1 circuit 3 power status	0	---	0: Get 1: Wait 2: Man 3: Rot 4: Defr 5: PmpD 6: Off 7: Prev	I	R	7
---	---	Compressor 1 running power circuit 3	0	%	0...999	I	R	4
---	---	Envelope working point circuit 3	0	---	0: - 1: Z1:Ok 2: Z2:HiDP 3: Z3:HiDscgP 4: Z4:HiCurr 5: Z5:HiSuctP 6: Z6:LoDP 7: Z7:LoPRat 8: Z8:LoDscgP 9: Z9:LoSuctP	I	R	11
---	---	Discharge temperature circuit 3	0.0	°C/°F	-999.9...999.9	A	R	56
---	---	Discharge pressure circuit 3	0.0	barg/psig	-999.9...999.9	A	R	48
---	---	Condensing temperature circuit 3	0.0	°C/°F	-999.9...999.9	A	R	52
---	---	Compressor 1 device available status circuit 3	0	---	0: Off 1: --- 2: On 3: --- 4: --- 5: --- 6: Force Off 7: --- 8: --- 9: --- 10: Alarm 11: Off 12: On 13: Man 14: PumpDown 15: ---	I	R	15
---	---	Compressor 1 circuit 3 On/Off countdown	0	s	0...999	I	R	
---	---	Compressor 1 running phase circuit 3 (STEP configuration)	0	---	0: --- 1: Start up 2: --- 3: Step 1 4: Step 2 5: Step 3 6: Step 4 7: Shutting Off 8: ---	I	R	244
---	---	Compressor 1 running phase circuit 3 (STEPLESS configuration)	0	---	0: --- 1: StartUp 2: StarUp incr. 3: Increase 4: Hold 5: Decrease 6: Fast decrease 7: ShutOff decr. 8: ShutOff	I	R	244
---	---	Compressor 1 running phase circuit 3 (INVERTER configuration)	0	---	0: --- 1: StartUp 2: ---	I	R	244

Parameter code	PWD	Description	Default	UOM	Range	Type	R/W	BMS index
					3: Running 4: Running 5: Running 6: Running 7: ShutOff 8: ---			
---	---	Inverter frequency compressor 1 circuit 3	0.0	---	0.0...999.9	A	R	4
---	---	Compressor 1 phase countdown circuit 3	0	s	0...999	I	R	
---	---	Suction temperature circuit 3	0.0	°C/°F	-999.9...999.9	A	R	44
---	---	Suction pressure circuit 3	0.0	barg/psig	-999.9...999.9	A	R	36
---	---	Evaporation temperature circuit 3	0.0	°C/°F	-999.9...999.9	A	R	40
---	---	External temperature	0.0	°C/°F	-999.9...999.9	A	R	57
---	---	Condenser fan pressure probe value circuit 3	2.0	barg/psig	0.0...999.9	A	R	226
---	---	Condenser fan temperature probe value circuit 3	13.0	°C/°F	0.0...999.9	A	R	230
---	---	Number of defrost phase actually running circuit 3	0	---	0 1: Defr.: check 2: Defr.: off sim.synch 3: Defr.: decr.comp.in 4: Defr.: incr.comp.100% 5: Defr.: running 6: Defr.: decr.comp.out 7: Defr.: dripping 8: Defr.: post-dripping	I	R	289
---	---	Condenser fan setpoint circuit 3	13.0	°C/°F	0.0...999.9	A	R	8
---	---	Condenser fan output request circuit 3	13.0	%	0.0...999.9	A	R	12
---	---	Condenser fan circuit 3 in manual mode	0	---	0 1: Man	D	R	
---	---	Valve opening percent circuit 3	0.0	---	0.0...999.0	A	R	23
---	---	Discharge Superheat circuit 3	0.0	°C/°F	-3276.8...3276.7	A	R	16
B055	---	Manual positioning enable - Circ3	0	---	0 1: Man	D	R	490
---	---	EVD status circuit 3	0	---	0: --- 1: Close 2: Close 3: Std-by 4: Pos 5: Pos 6: Wait 7: On 8: On 9: On 10: On 11: On 12: On 13: On 14: Init 15: On 16: Pos 17: Pos	I	R	334
---	---	EEV position circuit 3	0	---	0...9999	I	R	19
---	---	Superheat circuit 3	0.0	°C/°F	-3276.8...3276.7	A	R	20
---	---	Rotation request compressor 1 circuit 4	0	%	0...999	I	R	256
---	---	Compressor 1 circuit 4 power status	0	---	0: Get 1: Wait 2: Man 3: Rot 4: Defr 5: PmpD 6: Off 7: Prev	I	R	8
---	---	Compressor 1 running power circuit 4	0	%	0...999	I	R	3
---	---	Envelope working point circuit 4	0	---	0: - 1: Z1:Ok 2: Z2:HiDP 3: Z3:HiDscgP 4: Z4:HiCurr 5: Z5:HiSuctP 6: Z6:LoDP 7: Z7:LoPRat 8: Z8:LoDscgP 9: Z9:LoSuctP	I	R	12
---	---	Discharge temperature circuit 4	0.0	°C/°F	-999.9...999.9	A	R	55
---	---	Discharge pressure circuit 4	0.0	barg/psig	-999.9...999.9	A	R	47
---	---	Condensing temperature circuit 4	0.0	°C/°F	-999.9...999.9	A	R	51
---	---	Compressor 1 device available status circuit 4	0	---	0: Off 1: --- 2: On 3: --- 4: --- 5: --- 6: Force Off 7: --- 8: --- 9: --- 10: Alarm 11: Off 12: On 13: Man 14: PumpDown 15: ---	I	R	16
---	---	Compressor 1 circuit 4 On/Off countdown	0	s	0...999	I	R	
---	---	Compressor 1 running phase circuit 4 (STEP configuration)	0	---	0: --- 1: Start up 2: --- 3: Step 1 4: Step 2 5: Step 3	I	R	255

Parameter code	PWD	Description	Default	UOM	Range	Type	R/W	BMS index
					6: Step 4 7: Shutting Off 8: --- 0: --- 1: StartUp 2: StarUp incr. 3: Increase 4: Hold 5: Decrease 6: Fast decrease 7: ShutOff decr. 8: ShutOff			
---	---	Compressor 1 running phase circuit 4 (STEPLESS configuration)	0	---		I	R	255
---	---	Compressor 1 running phase circuit 4 (INVERTER configuration)	0	---	0: --- 1: StartUp 2: --- 3: Running 4: Running 5: Running 6: Running 7: ShutOff 8: ---	I	R	255
---	---	Inverter frequency compressor 1 circuit 4	0.0	---	0.0...999.9	A	R	3
---	---	Compressor 1 phase countdown circuit 4	0	s	0...999	I	R	
---	---	Suction temperature circuit 4	0.0	°C/°F	-999.9...999.9	A	R	43
---	---	Suction pressure circuit 4	0.0	barg/psig	-999.9...999.9	A	R	35
---	---	Evaporation temperature circuit 4	0.0	°C/°F	-999.9...999.9	A	R	39
---	---	External temperature	0.0	°C/°F	-999.9...999.9	A	R	57
---	---	Condenser fan pressure probe value circuit 4	2.0	barg/psig	0.0...999.9	A	R	227
---	---	Condenser fan temperature probe value circuit 4	13.0	°C/°F	0.0...999.9	A	R	231
---	---	Number of defrost phase actually running circuit 4	0	---	0 1: Defr.: check 2: Defr.: off sim.synch 3: Defr.: decr.comp.in 4: Defr.: incr.comp.100% 5: Defr.: running 6: Defr.: decr.comp.out 7: Defr.: dripping 8: Defr.: post-dripping	I	R	290
---	---	Condenser fan setpoint circuit 4	13.0	°C/°F	0.0...999.9	A	R	7
---	---	Condenser fan output request circuit 4	13.0	%	0.0...999.9	A	R	11
---	---	Condenser fan circuit 4 in manual mode	0	---	0 1: Man	D	R	
---	---	Valve opening percent circuit 4	0.0	---	0.0...999.0	A	R	24
---	---	Discharge Superheat circuit 4	0.0	°C/°F	-3276.8...3276.7	A	R	15
B057	---	Manual positioning enable - Circ4	0	---	0 1: Man	D	R	491
---	---	EVD status circuit 4	0	---	0: --- 1: Close 2: Close 3: Std-by 4: Pos 5: Pos 6: Wait 7: On 8: On 9: On 10: On 11: On 12: On 13: On 14: Init 15: On 16: Pos 17: Pos	I	R	336
---	---	EEV position circuit 4	0	---	0...9999	I	R	20
---	---	Superheat circuit 4	0.0	°C/°F	-3276.8...3276.7	A	R	19
---	---	Evaporator Flow switch status	0	---	0: Ok 1: Al	D	R	78
---	---	Number evaporator pump On	0	---	0: Off 1: P1:On 2: P2:On	I	R	331
---	---	Outlet water temperature	0.0	°C/°F	-999.9...999.9	A	R	25
---	---	Inlet water temperature	0.0	°C/°F	0.0...99.9	A	R	26
---	---	Actual setpoint	0.0	°C/°F	0.0...999.9	A	R	27
---	---	Power request	0.0	%	0.0...999.9	A	R	28
---	---	Condenser Flow switch status	0	---	0: Ok 1: Al	D	R	81
---	---	Number condenser pump On	0	---	0: Off 1: P1:On 2: P2:On	I	R	279
---	---	External temperature	0.0	°C/°F	-999.9...999.9	A	R	57
Da42	---	Ignition type	1	---	0 1: wind.A 2: delta	I	R	339
---	---	Position Compressor 1 circuit 1 direct start	0	---	0...99	I	R	218
---	---	Compressor 1 circuit 1 Direct/PartWinding A/Delta relay	0	---	0: Off 1: On	D	R	1
Da02	---	Compressor 1 manual control circuit 1	0	%	0: Auto 1: 000% 2: 001% 3: 002% 4: 003% ... 98: 097% 99: 098% 100: 099% 101: 100%	I	R	21

Parameter code	PWD	Description	Default	UOM	Range	Type	R/W	BMS index
---	---	Compressor 1 circuit 1 working hours	0	x1000h	0...999	I	R	25
---	---	Compressor 1 circuit 1 working hours	0	h	0...999	I	R	29
Da01	---	Compressor 1 hour threshold	30	x1000h	0...999	I	R	33
Da42	---	Ignition type	1	---	0 1: wind.B 2: star	I	R	339
---	---	Position Compressor 1 circuit 1 start or PartWinding B	0	---	0...99	I	R	224
---	---	Compressor 1 circuit 1 Star/PartWinding B relay	0	---	0: Off 1: On	D	R	6
---	---	Start signal Inverter compressor 1 circuit 1	0	---	0...99	I	R	221
---	---	Inverter start request compressor 1 circuit 1	0	---	0: Off 1: On	D	R	9
Da02	---	Compressor 1 manual control circuit 1	0	%	0: Auto 1: 000% 2: 001% 3: 002% 4: 003% ... 98: 097% 99: 098% 100: 099% 101: 100%	I	R	21
---	---	Compressor 1 circuit 1 working hours	0	x1000h	0...999	I	R	25
---	---	Compressor 1 circuit 1 working hours	0	h	0...999	I	R	29
Da01	---	Compressor 1 hour threshold	30	x1000h	0...999	I	R	33
---	---	Inverter request to compressor 1 circuit 1	0.0	---	0.0...100.0	A	R	29
---	---	Reset Inverter alarms compressor 1 circuit 1	0	---	0...99	I	R	219
---	---	Reset Inverter alarms compressor 1 circuit 1	0	---	0: Off 1: On	D	R	13
---	---	Digital output value of Reset Inverter alarms compressor 1 circuit 1	0	---	0...1	D	R	394
---	---	Emergency shutdown Inverter compressor 1 circuit 1	0	---	0...99	I	R	220
---	---	Immediate Shutoff of compressor inverter 1	0	---	0: Off 1: On	D	R	17
---	---	Digital output value of Immediate Shutoff of compressor	0	---	0...1	D	R	395
---	---	Position Compressor 1 valve 1 circuit 1	0	---	0...99	I	R	225
---	---	Compressor 1 valve 1 command circuit 1	0	---	0: Dsbl 1: Open 2: Clos 3: Int 4: Puls	I	R	37
---	---	Compressor 1 valve 1 relay circuit 1	0	---	0: Off 1: On	D	R	396
---	---	Position Compressor 1 valve 2 circuit 1	0	---	0...99	I	R	226
---	---	Compressor 1 valve 2 command circuit 1	0	---	0: Dsbl 1: Open 2: Clos 3: Int 4: Puls	I	R	41
---	---	Compressor 1 valve 2 relay circuit 1	0	---	0: Off 1: On	D	R	397
---	---	Position Compressor 1 valve 3 circuit 1	0	---	0...99	I	R	227
---	---	Compressor 1 valve 3 command circuit 1	0	---	0: Dsbl 1: Open 2: Clos 3: Int 4: Puls	I	R	45
---	---	Compressor 1 valve 3 relay circuit 1	0	---	0: Off 1: On	D	R	398
---	---	Position Compressor 1 valve 4 circuit 1	0	---	0...99	I	R	228
---	---	Compressor 1 valve 4 command circuit 1	0	---	0: Dsbl 1: Open 2: Clos 3: Int 4: Puls	I	R	49
---	---	Compressor 1 valve 4 relay circuit 1	0	---	0: Off 1: On	D	R	399
---	---	Position Solenoid valve circuit 1	0	---	0...99	I	R	411
---	---	Solenoid valve circuit 1 status	0	---	0: Off 1: On	D	R	21
---	---	Digital output value of solenoid valve circuit 1	0	---	0...1	D	R	546
---	---	Position 4way valve circuit 1	0	---	0...99	I	R	392
---	---	Status of 4way valve circuit 1	0	---	0: Off 1: On	D	R	25
---	---	Digital output value of 4way valve circuit 1	0	---	0...1	D	R	540
---	---	Position Eco compressor 1 circuit 1	0	---	0...99	I	R	324
---	---	Eco compressor 1 relay circuit 1	0	---	0: Off 1: On	D	R	29
---	---	Digital output value of Eco compressor 1 circuit 1	0	---	0...1	D	R	473
---	---	Position Liquid injection compressor 1 circuit 1	0	---	0...99	I	R	343
---	---	Liquid injection compressor 1 circuit 1 status	0	---	0: Off 1: On	D	R	33
---	---	Digital output status of Liquid Injection compressor 1 circuit 1	0	---	0...1	D	R	502
---	---	Position Condenser fan 1 circuit 1	0	---	0...99	I	R	265
---	---	Condenser 1 status	0	---	0: Off 1: On	D	R	37
---	---	Digital output status of condenser fan circuit 1	0	---	0...1	D	R	419
C006	---	Condenser Fan manual command circuit 1	0	%	0: Auto 1: 000% 2: 001% 3: 002% 4: 003% ...	I	R	53

Parameter code	PWD	Description	Default	UOM	Range	Type	R/W	BMS index
					98: 097% 99: 098% 100: 099% 101: 100%			
---	---	Condenser fan 1 circuit 1 working hours	0	x1000h	0...999	I	R	57
---	---	Condenser fan 1 circuit 1 working hours	0	h	0...999	I	R	62
C005	---	Circuit 1 condenser fan 1 maintenance hour threshold	99	x1000h	0...999	I	R	65
---	---	Condenser fan 1 output request circuit 1	13.0	%	0.0...999.9	A	R	9
C006	---	Condenser Fan manual command circuit 1	0	%	0: Auto 1: 000% 2: 001% 3: 002% 4: 003% ... 98: 097% 99: 098% 100: 099% 101: 100%	I	R	53
---	---	Condenser fan 1 circuit 1 working hours	0	x1000h	0...999	I	R	57
---	---	Condenser fan 1 circuit 1 working hours	0	h	0...999	I	R	62
C005	---	Circuit 1 condenser fan 1 maintenance hour threshold	99	x1000h	0...999	I	R	65
---	---	Position Condenser fan 1 circuit 1	0	---	0...99	I	R	265
---	---	Condenser 1 status	0	---	0: Off 1: On	D	R	37
---	---	Digital output status of condenser fan circuit 1	0	---	0...1	D	R	419
C053	---	Condenser Fan 1 manual command circuit 1	0	---	0: Auto 1: Off 2: On	I	R	69
---	---	Condenser fan 1 circuit 1 working hours	0	x1000h	0...999	I	R	57
---	---	Condenser fan 1 circuit 1 working hours	0	h	0...999	I	R	62
C005	---	Circuit 1 condenser fan 1 maintenance hour threshold	99	x1000h	0...999	I	R	65
---	---	Position Condenser fan 2 circuit 1	0	---	0...99	I	R	269
---	---	Condenser fan 2 status circuit 1	0	---	0: Off 1: On	D	R	41
---	---	Digital output status of condenser fan 2 circuit 1	0	---	0...1	D	R	427
C055	---	Condenser Fan 2 manual command circuit 1	0	---	0: Auto 1: Off 2: On	I	R	73
---	---	Condenser fan 2 circuit 1 working hours	0	x1000h	0...32767	I	R	77
---	---	Condenser fan 2 circuit 1 working hours	0	h	0...32767	I	R	81
C054	---	Circuit 1 condenser fan 2 maintenance hour threshold	99	x1000h	0...999	I	R	85
---	---	Position Condenser fan 3 circuit 1	0	---	0...32767	I	R	273
---	---	Condenser fan 3 status circuit 1	0	---	0: Off 1: On	D	R	45
---	---	Digital output status of condenser fan 3 circuit 1	0	---	0...1	D	R	431
C057	---	Condenser Fan 3 manual command circuit 1	0	---	0: Auto 1: Off 2: On	I	R	89
---	---	Condenser fan 3 circuit 1 working hours	0	x1000h	0...999	I	R	93
---	---	Condenser fan 3 circuit 1 working hours	0	h	0...999	I	R	97
C056	---	Circuit 1 condenser fan 3 maintenance hour threshold	99	x1000h	0...999	I	R	101
Da42	---	Ignition type	1	---	0 1: wind.A 2: delta	I	R	339
---	---	Position Compressor 1 circuit 2 direct start	0	---	0...99	I	R	229
---	---	Compressor 1 circuit 2 Direct/PartWinding A/Delta relay	0	---	0: Off 1: On	D	R	2
Da04	---	Compressor 1 manual control circuit 2	0	%	0: Auto 1: 000% 2: 001% 3: 002% 4: 003% ... 98: 097% 99: 098% 100: 099% 101: 100%	I	R	22
---	---	Compressor 1 circuit 2 working hours	0	x1000h	0...999	I	R	26
---	---	Compressor 1 circuit 2 working hours	0	h	0...999	I	R	30
Da03	---	Compressor 2 hour threshold	30	x1000h	0...999	I	R	34
Da42	---	Ignition type	1	---	0 1: wind.B 2: star	I	R	339
---	---	Position Compressor 1 circuit 2 start or PartWinding B	0	---	0...99	I	R	235
---	---	Compressor 1 circuit 2 Star/PartWinding B relay	0	---	0: Off 1: On	D	R	5
---	---	Start signal Inverter compressor 1 circuit 2	0	---	0...99	I	R	232
---	---	Inverter start request compressor 1 circuit 2	0	---	0: Off 1: On	D	R	10
Da04	---	Compressor 1 manual control circuit 2	0	%	0: Auto 1: 000% 2: 001% 3: 002% 4: 003% ... 98: 097% 99: 098% 100: 099% 101: 100%	I	R	22
---	---	Compressor 1 circuit 2 working hours	0	x1000h	0...999	I	R	26

Parameter code	PWD	Description	Default	UOM	Range	Type	R/W	BMS index
---	---	Compressor 1 circuit 2 working hours	0	h	0...999	I	R	30
Da03	---	Compressor 2 hour threshold	30	x1000h	0...999	I	R	34
---	---	Inverter request to compressor 1 circuit 2	0.0	---	0.0...100.0	A	R	30
---	---	Reset Inverter alarms compressor 1 circuit 2	0	---	0...99	I	R	230
---	---	Reset Inverter alarms compressor 1 circuit 2	0	---	0: Off 1: On	D	R	14
---	---	Digital output value of Reset Inverter alarms compressor 1 circuit 2	0	---	0...1	D	R	400
---	---	Emergency shutdown Inverter compressor 1 circuit 2	0	---	0...99	I	R	231
---	---	Immediate Shutoff of compressor	0	---	0: Off 1: On	D	R	18
---	---	Digital output value of Immediate Shutoff of compressor	0	---	0...1	D	R	401
---	---	Position Compressor 1 valve 1 circuit 2	0	---	0...99	I	R	236
---	---	Compressor 1 valve 1 command circuit 2	0	---	0: Dsbl 1: Open 2: Clos 3: Int 4: Puls	I	R	38
---	---	Compressor 1 circuit 2 valve 1 relay	0	---	0: Off 1: On	D	R	402
---	---	Position Compressor 1 valve 2 circuit 2	0	---	0...99	I	R	237
---	---	Compressor 1 valve 2 command circuit 2	0	---	0: Dsbl 1: Open 2: Clos 3: Int 4: Puls	I	R	42
---	---	Compressor 1 circuit 2 valve 2 relay	0	---	0: Off 1: On	D	R	403
---	---	Position Compressor 1 valve 3 circuit 2	0	---	0...99	I	R	238
---	---	Compressor 1 valve 3 command circuit 2	0	---	0: Dsbl 1: Open 2: Clos 3: Int 4: Puls	I	R	46
---	---	Compressor 1 circuit 2 valve 3 relay	0	---	0: Off 1: On	D	R	404
---	---	Position Compressor 1 valve 4 circuit 2	0	---	0...99	I	R	239
---	---	Compressor 1 valve 4 command circuit 2	0	---	0: Dsbl 1: Open 2: Clos 3: Int 4: Puls	I	R	50
---	---	Compressor 1 circuit 2 valve 4 relay	0	---	0: Off 1: On	D	R	405
---	---	Position Solenoid valve circuit 2	0	---	0...99	I	R	412
---	---	Solenoid valve circuit 2 status	0	---	0: Off 1: On	D	R	22
---	---	Digital output status of solenoid valve circuit 2	0	---	0...1	D	R	547
---	---	Position 4way valve circuit 2	0	---	0...99	I	R	393
---	---	Status of 4way valve circuit 2	0	---	0: Off 1: On	D	R	26
---	---	Digital output status of 4way valve circuit 2	0	---	0...1	D	R	541
---	---	Position Eco compressor 1 circuit 2	0	---	0...99	I	R	325
---	---	Eco compressor 1 circuit 2 relay	0	---	0: Off 1: On	D	R	30
---	---	Digital output status of Eco compressor 1 circuit 2	0	---	0...1	D	R	474
---	---	Position Liquid injection compressor 1 circuit 2	0	---	0...99	I	R	344
---	---	Liquid injection compressor 1 circuit 2 status	0	---	0: Off 1: On	D	R	34
---	---	Digital output status of Liquid Injection compressor 1 circuit 2	0	---	0...1	D	R	503
---	---	Position Condenser fan 1 circuit 2	0	---	0...99	I	R	266
---	---	Condenser 2 status	0	---	0: Off 1: On	D	R	38
---	---	Digital output status of condenser fan circuit 2	0	---	0...1	D	R	420
C008	---	Condenser Fan manual command circuit 2	0	%	0: Auto 1: 000% 2: 001% 3: 002% 4: 003% ... 98: 097% 99: 098% 100: 099% 101: 100%	I	R	54
---	---	Condenser fan1 circuit 2 working hours	0	x1000h	0...999	I	R	58
---	---	Condenser fan 1 circuit 2 working hours	0	h	0...999	I	R	61
C007	---	Circuit 2 condenser fan 1 maintenance hour threshold	99	x1000h	0...999	I	R	66
---	---	Condenser fan output request circuit 2	13.0	%	0.0...999.9	A	R	10
C008	---	Condenser Fan manual command circuit 2	0	%	0: Auto 1: 000% 2: 001% 3: 002% 4: 003% ... 98: 097% 99: 098% 100: 099% 101: 100%	I	R	54
---	---	Condenser fan1 circuit 2 working hours	0	x1000h	0...999	I	R	58
---	---	Condenser fan 1 circuit 2 working hours	0	h	0...999	I	R	61
C007	---	Circuit 2 condenser fan 1 maintenance hour threshold	99	x1000h	0...999	I	R	66

Parameter code	PWD	Description	Default	UOM	Range	Type	R/W	BMS index
---	---	Position Condenser fan 1 circuit 2	0	---	0...99	I	R	266
---	---	Condenser 2 status	0	---	0: Off 1: On	D	R	38
---	---	Digital output status of condenser fan circuit 2	0	---	0...1	D	R	420
C058	---	Condenser Fan 1 manual command circuit 2	0	---	0: Auto 1: Off 2: On	I	R	70
---	---	Condenser fan1 circuit 2 working hours	0	x1000h	0...999	I	R	58
---	---	Condenser fan 1 circuit 2 working hours	0	h	0...999	I	R	61
C007	---	Circuit 2 condenser fan 1 maintenance hour threshold	99	x1000h	0...999	I	R	66
---	---	Position Condenser fan 2 circuit 2	0	---	0...99	I	R	270
---	---	Condenser fan 2 status circuit 2	0	---	0: Off 1: On	D	R	42
---	---	Digital output status of condenser fan 2 circuit 2	0	---	0...1	D	R	428
C060	---	Condenser Fan 2 manual command circuit 2	0	---	0: Auto 1: Off 2: On	I	R	74
---	---	Condenser fan 2 circuit 2 working hours	0	x1000h	0...999	I	R	78
---	---	Condenser fan 2 circuit 2 working hours	0	h	0...999	I	R	82
C059	---	Circuit 2 condenser fan 2 maintenance hour threshold	99	x1000h	0...999	I	R	86
---	---	Position Condenser fan 3 circuit 2	0	---	0...99	I	R	274
---	---	Condenser fan 3 status circuit 2	0	---	0: Off 1: On	D	R	46
---	---	Digital output status of condenser fan 3 circuit 2	0	---	0...1	D	R	432
C062	---	Condenser Fan 3 manual command circuit 2	0	---	0: Auto 1: Off 2: On	I	R	90
---	---	Condenser fan 3 circuit 2 working hours	0	x1000h	0...999	I	R	94
---	---	Condenser fan 3 circuit 2 working hours	0	h	0...999	I	R	98
C061	---	Circuit 2 condenser fan 3 maintenance hour threshold	99	x1000h	0...999	I	R	102
Da42	---	Ignition type	1	---	0 1: wind.A 2: delta	I	R	339
---	---	Position Compressor 1 circuit 3 direct start	0	---	0...99	I	R	240
---	---	Compressor 1 circuit 3 Direct/PartWinding A/Delta relay	0	---	0: Off 1: On	D	R	4
Da86	---	Compressor 1 manual control circuit 3	0	%	0: Auto 1: 000% 2: 001% 3: 002% 4: 003% ... 98: 097% 99: 098% 100: 099% 101: 100%	I	R	24
---	---	Compressor 1 circuit 3 working hours	0	x1000h	0...999	I	R	28
---	---	Compressor 1 circuit 3 working hours	0	h	0...999	I	R	32
Da85	---	Compressor 3 hour threshold	30	x1000h	0...999	I	R	36
Da42	---	Ignition type	1	---	0 1: wind.B 2: star	I	R	339
---	---	Position Compressor 1 circuit 3 start or PartWinding B	0	---	0...99	I	R	246
---	---	Compressor 1 circuit 3 Star/PartWinding B relay	0	---	0: Off 1: On	D	R	8
---	---	Start signal Inverter compressor 1 circuit 3	0	---	0...99	I	R	243
---	---	Inverter start request compressor 1 circuit 3	0	---	0: Off 1: On	D	R	12
Da86	---	Compressor 1 manual control circuit 3	0	%	0: Auto 1: 000% 2: 001% 3: 002% 4: 003% ... 98: 097% 99: 098% 100: 099% 101: 100%	I	R	24
---	---	Compressor 1 circuit 3 working hours	0	x1000h	0...999	I	R	28
---	---	Compressor 1 circuit 3 working hours	0	h	0...999	I	R	32
Da85	---	Compressor 3 hour threshold	30	x1000h	0...999	I	R	36
---	---	Inverter request to compressor 1 circuit 3	0.0	---	0.0...100.0	A	R	31
---	---	Reset Inverter alarms compressor 1 circuit 3	0	---	0...99	I	R	241
---	---	Reset Inverter alarms compressor 1 circuit 3	0	---	0: Off 1: On	D	R	16
---	---	Digital output value of Reset Inverter alarms compressor 1 circuit 3	0	---	0...1	D	R	406
---	---	Emergency shutdown Inverter compressor 1 circuit 3	0	---	0...99	I	R	242
---	---	Immediate Shutoff of compressor	0	---	0: Off 1: On	D	R	20
---	---	Digital output value of Immediate Shutoff of compressor	0	---	0...1	D	R	407
---	---	Position Compressor 1 valve 1 circuit 3	0	---	0...99	I	R	247
---	---	Compressor 1 valve 1 command circuit 3	0	---	0: Dsbl 1: Open 2: Clos 3: Int 4: Puls	I	R	40
---	---	Compressor 1 valve 1 relay circuit 3	0	---	0: Off 1: On	D	R	408
---	---	Position Compressor 1 valve 2 circuit 3	0	---	0...99	I	R	248

Parameter code	PWD	Description	Default	UOM	Range	Type	R/W	BMS index
---	---	Compressor 1 valve 2 command circuit 3	0	---	0: Dsbl 1: Open 2: Clos 3: Int 4: Puls	I	R	44
---	---	Compressor 1 valve 2 relay circuit 3	0	---	0: Off 1: On	D	R	409
---	---	Position Compressor 1 valve 3 circuit 3	0	---	0..99	I	R	249
---	---	Compressor 1 valve 3 command circuit 3	0	---	0: Dsbl 1: Open 2: Clos 3: Int 4: Puls	I	R	48
---	---	Compressor 1 valve 3 relay circuit 3	0	---	0: Off 1: On	D	R	410
---	---	Position Compressor 1 valve 4 circuit 3	0	---	0..99	I	R	250
---	---	Compressor 1 valve 4 command circuit 3	0	---	0: Dsbl 1: Open 2: Clos 3: Int 4: Puls	I	R	52
---	---	Compressor 1 valve 4 relay circuit 3	0	---	0: Off 1: On	D	R	411
---	---	Position Solenoid valve circuit 3	0	---	0..99	I	R	413
---	---	Solenoid valve circuit 3 status	0	---	0: Off 1: On	D	R	23
---	---	Digital output value of solenoid valve circuit 3	0	---	0..1	D	R	548
---	---	Position 4way valve circuit 3	0	---	0..99	I	R	394
---	---	Status of 4way valve circuit 3	0	---	0: Off 1: On	D	R	27
---	---	Digital output value of 4way valve circuit 3	0	---	0..1	D	R	542
---	---	Position Eco compressor 1 circuit 3	0	---	0..99	I	R	326
---	---	Eco compressor 1 relay circuit 3	0	---	0: Off 1: On	D	R	31
---	---	Digital output value of Eco compressor 1 circuit 3	0	---	0..1	D	R	475
---	---	Position Liquid injection compressor 1 circuit 3	0	---	0..99	I	R	345
---	---	Liquid injection compressor 1 circuit 3 status	0	---	0: Off 1: On	D	R	35
---	---	Digital output status of Liquid Injection compressor 1 circuit 3	0	---	0..1	D	R	504
---	---	Position Condenser fan 1 circuit 3	0	---	0..99	I	R	267
---	---	Condenser 3 status	0	---	0: Off 1: On	D	R	39
---	---	Digital output status of condenser fan circuit 3	0	---	0..1	D	R	421
C050	---	Condenser Fan manual command circuit 3	0	%	0: Auto 1: 000% 2: 001% 3: 002% 4: 003% ... 98: 097% 99: 098% 100: 099% 101: 100%	I	R	56
---	---	Condenser fan 1 circuit 3 working hours	0	x1000h	0..999	I	R	60
---	---	Condenser fan 1 circuit 3 working hours	0	h	0..999	I	R	64
C049	---	Circuit 3 condenser fan1 maintenance hour threshold	99	x1000h	0..999	I	R	68
---	---	Condenser fan output request circuit 3	13.0	%	0.0..999.9	A	R	12
C050	---	Condenser Fan manual command circuit 3	0	%	0: Auto 1: 000% 2: 001% 3: 002% 4: 003% ... 98: 097% 99: 098% 100: 099% 101: 100%	I	R	56
---	---	Condenser fan 1 circuit 3 working hours	0	x1000h	0..999	I	R	60
---	---	Condenser fan 1 circuit 3 working hours	0	h	0..999	I	R	64
C049	---	Circuit 3 condenser fan1 maintenance hour threshold	99	x1000h	0..999	I	R	68
---	---	Position Condenser fan 1 circuit 3	0	---	0..99	I	R	267
---	---	Condenser 3 status	0	---	0: Off 1: On	D	R	39
---	---	Digital output status of condenser fan circuit 3	0	---	0..1	D	R	421
C053	---	Condenser Fan 1 manual command circuit 1	0	---	0: Auto 1: Off 2: On	I	R	69
---	---	Condenser fan 1 circuit 3 working hours	0	x1000h	0..999	I	R	60
---	---	Condenser fan 1 circuit 3 working hours	0	h	0..999	I	R	64
C049	---	Circuit 3 condenser fan1 maintenance hour threshold	99	x1000h	0..999	I	R	68
---	---	Position Condenser fan 2 circuit 3	0	---	0..99	I	R	271
---	---	Condenser fan 2 status circuit 3	0	---	0: Off 1: On	D	R	43
---	---	Digital output status of condenser fan 2 circuit 3	0	---	0..1	D	R	429
C065	---	Condenser Fan 2 manual command circuit 3	0	---	0: Auto 1: Off 2: On	I	R	75
---	---	Condenser fan 2 circuit 3 working hours	0	x1000h	0..999	I	R	79
---	---	Condenser fan 2 circuit 3 working hours	0	h	0..999	I	R	83
C064	---	Circuit 3 condenser fan 2 maintenance hour threshold	99	x1000h	0..999	I	R	87

Parameter code	PWD	Description	Default	UOM	Range	Type	R/W	BMS index
---	---	Position Condenser fan 3 circuit 3	0	---	0...99	I	R	275
---	---	Condenser fan 3 status circuit 3	0	---	0: Off 1: On	D	R	47
---	---	Digital output status of condenser fan 3 circuit 3	0	---	0...1	D	R	433
C067	---	Condenser Fan 3 manual command circuit 3	0	---	0: Auto 1: Off 2: On	I	R	91
---	---	Condenser fan 3 circuit 3 working hours	0	x1000h	0...999	I	R	95
---	---	Condenser fan 3 circuit 3 working hours	0	h	0...999	I	R	99
C066	---	Circuit 3 condenser fan 3 maintenance hour threshold	99	x1000h	0...999	I	R	103
Da42	---	Ignition type	1	---	0 1: wind.A 2: delta	I	R	339
---	---	Position Compressor 1 circuit 4 direct start	0	---	0...99	I	R	251
---	---	Compressor 1 circuit 4 Direct/PartWinding A/Delta relay	0	---	0: Off 1: On	D	R	3
Da88	---	Compressor 1 manual control circuit 4	0	%	0: Auto 1: 000% 2: 001% 3: 002% 4: 003% ... 98: 097% 99: 098% 100: 099% 101: 100%	I	R	23
---	---	Compressor 1 circuit 4 working hours	0	x1000h	0...999	I	R	27
---	---	Compressor 1 circuit 4 working hours	0	h	0...999	I	R	31
Da87	---	Compressor 4 hour threshold	30	x1000h	0...999	I	R	35
Da42	---	Ignition type	1	---	0 1: wind.B 2: star	I	R	339
---	---	Position Compressor 1 circuit 4 start or PartWinding B	0	---	0...99	I	R	257
---	---	Compressor 1 circuit 4 Star/PartWinding B relay	0	---	0: Off 1: On	D	R	7
---	---	Start signal Inverter compressor 1 circuit 4	0	---	0...99	I	R	254
---	---	Inverter start request compressor 1 circuit 4	0	---	0: Off 1: On	D	R	11
Da88	---	Compressor 1 manual control circuit 4	0	%	0: Auto 1: 000% 2: 001% 3: 002% 4: 003% ... 98: 097% 99: 098% 100: 099% 101: 100%	I	R	23
---	---	Compressor 1 circuit 4 working hours	0	x1000h	0...999	I	R	27
---	---	Compressor 1 circuit 4 working hours	0	h	0...999	I	R	31
Da87	---	Compressor 4 hour threshold	30	x1000h	0...999	I	R	35
---	---	Inverter request to compressor 1 circuit 4	0,0	---	0.0...100,0	A	R	32
---	---	Reset Inverter alarms compressor 1 circuit 4	0	---	0...99	I	R	252
---	---	Reset Inverter alarms compressor 1 circuit 4	0	---	0: Off 1: On	D	R	15
---	---	Digital output value of Reset Inverter alarms compressor 1 circuit 4	0	---	0...1	D	R	412
---	---	Emergency shutdown Inverter compressor 1 circuit 4	0	---	0...99	I	R	253
---	---	Immediate Shutoff of compressor	0	---	0: Off 1: On	D	R	19
---	---	Digital output value of Immediate Shutoff of compressor	0	---	0...1	D	R	413
---	---	Position Compressor 1 valve 1 circuit 4	0	---	0...99	I	R	258
---	---	Compressor 1 valve 1 command circuit 4	0	---	0: Dsbl 1: Open 2: Clos 3: Int 4: Puls	I	R	39
---	---	Compressor 1 valve 1 relay circuit 4	0	---	0: Off 1: On	D	R	414
---	---	Position Compressor 1 valve 2 circuit 4	0	---	0...99	I	R	259
---	---	Compressor 1 valve 2 command circuit 4	0	---	0: Dsbl 1: Open 2: Clos 3: Int 4: Puls	I	R	43
---	---	Compressor 1 valve 2 relay circuit 4	0	---	0: Off 1: On	D	R	415
---	---	Position Compressor 1 valve 3 circuit 4	0	---	0...99	I	R	260
---	---	Compressor 1 valve 3 command circuit 4	0	---	0: Dsbl 1: Open 2: Clos 3: Int 4: Puls	I	R	47
---	---	Compressor 1 valve 3 relay circuit 4	0	---	0: Off 1: On	D	R	416
---	---	Position Compressor 1 valve 4 circuit 4	0	---	0...99	I	R	261
---	---	Compressor 1 valve 4 command circuit 4	0	---	0: Dsbl 1: Open 2: Clos 3: Int 4: Puls	I	R	51
---	---	Compressor 1 valve 4 relay circuit 4	0	---	0: Off 1: On	D	R	417

Parameter code	PWD	Description	Default	UOM	Range	Type	R/W	BMS index
---	---	Position Solenoid valve circuit 4	0	---	0...99	I	R	414
---	---	Solenoid valve circuit 4 status	0	---	0: Off 1: On	D	R	24
---	---	Digital output value of solenoid valve circuit 4	0	---	0...1	D	R	549
---	---	Position 4way valve circuit 4	0	---	0...99	I	R	395
---	---	Status of 4way valve circuit 4	0	---	0: Off 1: On	D	R	28
---	---	Digital output value of 4way valve circuit 4	0	---	0...1	D	R	543
---	---	Position Eco compressor 1 circuit 4	0	---	0...99	I	R	327
---	---	Eco compressor 1 relay circuit 4	0	---	0: Off 1: On	D	R	32
---	---	Digital output value of Eco compressor 1 circuit 4	0	---	0...1	D	R	476
---	---	Position Liquid injection compressor 1 circuit 4	0	---	0...99	I	R	346
---	---	Liquid injection compressor 1 circuit 4 status	0	---	0: Off 1: On	D	R	36
---	---	Digital output status of Liquid Injection compressor 1 circuit 4	0	---	0...1	D	R	505
---	---	Position Condenser fan 1 circuit 4	0	---	0...99	I	R	268
---	---	Condenser 4 status	0	---	0: Off 1: On	D	R	40
---	---	Digital output status of condenser fan circuit 4	0	---	0...1	D	R	422
C052	---	Condenser Fan manual command circuit 4	0	%	0: Auto 1: 000% 2: 001% 3: 002% 4: 003% ... 98: 097% 99: 098% 100: 099% 101: 100%	I	R	55
---	---	Condenser fan 1 circuit 4 working hours	0	x1000h	0...999	I	R	59
---	---	Condenser fan 1 circuit 4 working hours	0	h	0...999	I	R	63
C051	---	Circuit 4 condenser fan 1 maintenance hour threshold	99	x1000h	0...999	I	R	67
---	---	Condenser fan output request circuit 4	13.0	%	0.0...999.9	A	R	11
C052	---	Condenser Fan manual command circuit 4	0	%	0: Auto 1: 000% 2: 001% 3: 002% 4: 003% ... 98: 097% 99: 098% 100: 099% 101: 100%	I	R	55
---	---	Condenser fan 1 circuit 4 working hours	0	x1000h	0...999	I	R	59
---	---	Condenser fan 1 circuit 4 working hours	0	h	0...999	I	R	63
C051	---	Circuit 4 condenser fan 1 maintenance hour threshold	99	x1000h	0...999	I	R	67
---	---	Position Condenser fan 1 circuit 4	0	---	0...99	I	R	268
---	---	Condenser 4 status	0	---	0: Off 1: On	D	R	40
---	---	Digital output status of condenser fan circuit 4	0	---	0...1	D	R	422
C053	---	Condenser Fan 1 manual command circuit 1	0	---	0: Auto 1: Off 2: On	I	R	69
---	---	Condenser fan 1 circuit 4 working hours	0	x1000h	0...999	I	R	59
---	---	Condenser fan 1 circuit 4 working hours	0	h	0...999	I	R	63
C051	---	Circuit 4 condenser fan 1 maintenance hour threshold	99	x1000h	0...999	I	R	67
---	---	Position Condenser fan 2 circuit 4	0	---	0...99	I	R	272
---	---	Condenser fan 2 status circuit 4	0	---	0: Off 1: On	D	R	44
---	---	Digital output status of condenser fan 2 circuit 4	0	---	0...1	D	R	430
C070	---	Condenser Fan 2 manual command circuit 4	0	---	0: Auto 1: Off 2: On	I	R	76
---	---	Condenser fan 2 circuit 4 working hours	0	x1000h	0...999	I	R	80
---	---	Condenser fan 2 circuit 4 working hours	0	h	0...999	I	R	84
C069	---	Circuit 4 condenser fan 2 maintenance hour threshold	99	x1000h	0...999	I	R	88
---	---	Position Condenser fan 3 circuit 4	0	---	0...99	I	R	276
---	---	Condenser fan 3 status circuit 4	0	---	0: Off 1: On	D	R	48
---	---	Digital output status of condenser fan 3 circuit 4	0	---	0...1	D	R	434
C072	---	Condenser Fan 3 manual command circuit 4	0	---	0: Auto 1: Off 2: On	I	R	92
---	---	Condenser fan 3 circuit 4 working hours	0	x1000h	0...999	I	R	96
---	---	Condenser fan 3 circuit 4 working hours	0	h	0...999	I	R	100
C071	---	Circuit 4 condenser fan 3 maintenance hour threshold	99	x1000h	0...999	I	R	104
---	---	Position Digital output value of evaporator pump 1	0	---	0...99	I	R	328
---	---	Evaporator pump 1 status	0	---	0: Off 1: On	D	R	49
---	---	Digital output status of evaporator pump 1	0	---	0...1	D	R	487
A002	---	Evaporator pump in manual mode	0	---	0: Auto 1: Off 2: On	I	R	105
---	---	Evaporator pump 1 working hours	0	x1000h	0...999	I	R	106
---	---	Evaporator pump 1 working hours	0	h	0...999	I	R	107
A001	---	Evaporator pump 1 maintenance hour threshold	99	x1000h	0...999	I	R	108

Parameter code	PWD	Description	Default	UOM	Range	Type	R/W	BMS index
---	---	Position Digital output value of evaporator pump 2	0	---	0...99	I	R	329
---	---	Evaporator pump 2 status	0	---	0: Off 1: On	D	R	50
---	---	Digital output status of evaporator pump 2	0	---	0...1	D	R	488
A002	---	Evaporator pump in manual mode	0	---	0: Auto 1: Off 2: On	I	R	105
---	---	Evaporator pump 2 working hours	0	x1000h	0...999	I	R	109
---	---	Evaporator pump 2 working hours	0	h	0...999	I	R	110
A003	---	Evaporator pump 2 maintenance hour threshold	99	x1000h	0...999	I	R	111
---	---	Evaporator pump 2 status	0	---	0: 0.0 1: 100.0	D	R	50
A002	---	Evaporator pump in manual mode	0	---	0: Auto 1: Off 2: On	I	R	105
---	---	Evaporator pump 2 working hours	0	x1000h	0...999	I	R	109
---	---	Evaporator pump 2 working hours	0	h	0...999	I	R	110
A003	---	Evaporator pump 2 maintenance hour threshold	99	x1000h	0...999	I	R	111
---	---	Position Condenser fan 1 circuit 1	0	---	0...99	I	R	265
---	---	Condenser 1 status	0	---	0: Off 1: On	D	R	37
---	---	Digital output status of condenser fan circuit 1	0	---	0...1	D	R	419
C002	---	Condenser pump in manual mode	0	---	0: Auto 1: Off 2: On	I	R	112
---	---	Condenser pump 1 working hours	0	x1000h	0...999	I	R	113
---	---	Condenser pump 1 working hours	0	h	0...999	I	R	114
C001	---	Condenser pump 1 maintenance hour threshold	99	x1000h	0...999	I	R	115
---	---	Position Condenser fan 1 circuit 2	0	---	0...99	I	R	266
---	---	Condenser 2 status	0	---	0: Off 1: On	D	R	38
---	---	Digital output status of condenser fan circuit 1	0	---	0...1	D	R	419
C002	---	Condenser pump in manual mode	0	---	0: Auto 1: Off 2: On	I	R	112
---	---	Condenser pump 2 working hours	0	x1000h	0...999	I	R	116
---	---	Condenser pump 2 working hours	0	h	0...999	I	R	117
C003	---	Condenser pump 2 maintenance hour threshold	99	x1000h	0...999	I	R	118
---	---	Antifreeze heater output channel	0	---	0...99	I	R	210
---	---	Antifreeze heater relay	0	---	0: Off 1: On	D	R	51
---	---	Digital output status of antifreeze heater	0	---	0...1	D	R	208
---	---	Position Free cooling	0	---	0...99	I	R	
---	---	Free cooling valve status	0	---	0: Off 1: On	D	R	52
---	---	Digital output status of Free cooling valve	0	---	0...1	D	R	
---	---	Free cooling valve status	0	---	0: 0.0 1: 100.0	D	R	52
---	---	Position General alarm	0	---	0...99	I	R	338
---	---	General alarm	0	---	0: Off 1: On	D	R	53
---	---	Digital output status of general alarm	0	---	0...1	D	R	494
---	---	Suction pressure circuit 1	0.0	barg/psig	-999.9...999.9	A	R	33
---	---	Evaporation temperature circuit 1	0.0	°C/°F	-999.9...999.9	A	R	37
---	---	Suction temperature circuit 1	0.0	°C/°F	-999.9...999.9	A	R	41
---	---	Discharge pressure circuit 1	0.0	barg/psig	-999.9...999.9	A	R	45
---	---	Condensing temperature circuit 1	0.0	°C/°F	-999.9...999.9	A	R	49
---	---	Discharge temperature circuit 1	0.0	°C/°F	-999.9...999.9	A	R	53
---	---	Suction pressure circuit 2	0.0	barg/psig	-999.9...999.9	A	R	34
---	---	Evaporation temperature circuit 2	0.0	°C/°F	-999.9...999.9	A	R	38
---	---	Suction temperature circuit 2	0.0	°C/°F	-999.9...999.9	A	R	42
---	---	Discharge pressure circuit 2	0.0	barg/psig	-999.9...999.9	A	R	46
---	---	Condensing temperature circuit 2	0.0	°C/°F	-999.9...999.9	A	R	50
---	---	Discharge temperature circuit 2	0.0	°C/°F	-999.9...999.9	A	R	54
---	---	Suction pressure circuit 3	0.0	barg/psig	-999.9...999.9	A	R	36
---	---	Evaporation temperature circuit 3	0.0	°C/°F	-999.9...999.9	A	R	40
---	---	Suction temperature circuit 3	0.0	°C/°F	-999.9...999.9	A	R	44
---	---	Discharge pressure circuit 3	0.0	barg/psig	-999.9...999.9	A	R	48
---	---	Condensing temperature circuit 3	0.0	°C/°F	-999.9...999.9	A	R	52
---	---	Discharge temperature circuit 3	0.0	°C/°F	-999.9...999.9	A	R	56
---	---	Suction pressure circuit 4	0.0	barg/psig	-999.9...999.9	A	R	35
---	---	Evaporation temperature circuit 4	0.0	°C/°F	-999.9...999.9	A	R	39
---	---	Suction temperature circuit 4	0.0	°C/°F	-999.9...999.9	A	R	43
---	---	Discharge pressure circuit 4	0.0	barg/psig	-999.9...999.9	A	R	47
---	---	Condensing temperature circuit 4	0.0	°C/°F	-999.9...999.9	A	R	51
---	---	Discharge temperature circuit 4	0.0	°C/°F	-999.9...999.9	A	R	55
---	---	Inlet water temperature	0.0	°C/°F	0.0...99.9	A	R	26
---	---	Outlet water temperature	0.0	°C/°F	-999.9...999.9	A	R	25
---	---	External temperature	0.0	°C/°F	-999.9...999.9	A	R	57
---	---	External temperature	0.0	°C/°F	-999.9...999.9	A	R	57
---	---	Current compressor 1 circuit 1	0.0	A	-999.9...999.9	A	R	61
---	---	Current compressor 1 circuit 2	0.0	A	-999.9...999.9	A	R	62
---	---	Current compressor 1 circuit 3	0.0	A	-999.9...999.9	A	R	64
---	---	Current compressor 1 circuit 4	0.0	A	-999.9...999.9	A	R	63
---	---	Low pressure switch circuit 1 status	0	---	0: Ok 1: Alarm	D	R	54
---	---	Digital input 6 status	0	---	0...1	D	R	465

Parameter code	PWD	Description	Default	UOM	Range	Type	R/W	BMS index
---	---	Oil level circuit 1	0	---	0: Ok 1: Alarm	D	R	58
---	---	Digital input 7 status	0	---	0...1	D	R	467
---	---	High pressure switch status circuit 1	0	---	0: Ok 1: Alarm	D	R	62
---	---	EVD digital input 1 circuit 1	0	---	0...1	D	R	442
---	---	Overload of compressor 1 circuit 1	0	---	0: Ok 1: Alarm	D	R	66
---	---	EVD digital input 2 circuit 1	0	---	0...1	D	R	456
---	---	Inverter RUN feedback compressor 1 circuit 1	0	---	0: Stop 1: Run	D	R	70
---	---	Digital input 13 status	0	---	0...1	D	R	453
---	---	Inverter alarm signal compressor 1 circuit 1	0	---	0: Ok 1: Alarm	D	R	74
---	---	EVD digital input 2 circuit 1	0	---	0...1	D	R	456
---	---	Low pressure switch status circuit 2	0	---	0: Ok 1: Alarm	D	R	55
---	---	Digital input 9 status	0	---	0...1	D	R	471
---	---	Oil level circuit 2	0	---	0: Ok 1: Alarm	D	R	59
---	---	Digital input 10 status	0	---	0...1	D	R	448
---	---	High pressure switch status circuit 2	0	---	0: Ok 1: Alarm	D	R	63
---	---	EVD digital input 1 circuit 2	0	---	0...1	D	R	443
---	---	Overload of compressor 1 circuit 2	0	---	0: Ok 1: Alarm	D	R	67
---	---	EVD digital input 2 circuit 2	0	---	0...1	D	R	457
---	---	Inverter RUN feedback compressor 1 circuit 2	0	---	0: Stop 1: Run	D	R	71
---	---	Digital input 14 status	0	---	0...1	D	R	455
---	---	Inverter alarm signal compressor 1 circuit 2	0	---	0: Ok 1: Alarm	D	R	75
---	---	EVD digital input 2 circuit 2	0	---	0...1	D	R	457
---	---	Low pressure switch circuit 3 status	0	---	0: Ok 1: Alarm	D	R	57
---	---	Digital input 6 status on Slave board	0	---	0...1	D	R	464
---	---	Oil level circuit 3	0	---	0: Ok 1: Alarm	D	R	61
---	---	Digital input 7 status on Slave board	0	---	0...1	D	R	466
---	---	High pressure switch status circuit 3	0	---	0: Ok 1: Alarm	D	R	65
---	---	EVD digital input 1 circuit 3	0	---	0...1	D	R	444
---	---	Overload of compressor 1 circuit 3	0	---	0: Ok 1: Alarm	D	R	69
---	---	EVD digital input 2 circuit 3	0	---	0...1	D	R	458
---	---	Inverter RUN feedback compressor 1 circuit 3	0	---	0: Stop 1: Run	D	R	72
---	---	Digital input 13 status on Slave board	0	---	0...1	D	R	452
---	---	Inverter alarm signal compressor 1 circuit 3	0	---	0: Ok 1: Alarm	D	R	76
---	---	EVD digital input 2 circuit 3	0	---	0...1	D	R	458
---	---	Low pressure switch circuit 4 status	0	---	0: Ok 1: Alarm	D	R	56
---	---	Digital input 9 status on Slave board	0	---	0...1	D	R	470
---	---	Oil level circuit 4	0	---	0: Ok 1: Alarm	D	R	60
---	---	Digital input 10 status on Slave board	0	---	0...1	D	R	447
---	---	High pressure switch status circuit 4	0	---	0: Ok 1: Alarm	D	R	64
---	---	EVD digital input 1 circuit 4	0	---	0...1	D	R	445
---	---	Overload of compressor 1 circuit 4	0	---	0: Ok 1: Alarm	D	R	68
---	---	EVD digital input 2 circuit 4	0	---	0...1	D	R	459
---	---	Inverter RUN feedback compressor 1 circuit 4	0	---	0: Stop 1: Run	D	R	73
---	---	Digital input 14 status on Slave board	0	---	0...1	D	R	454
---	---	Inverter alarm signal compressor 1 circuit 4	0	---	0: Ok 1: Alarm	D	R	77
---	---	EVD digital input 2 circuit 4	0	---	0...1	D	R	459
---	---	Evaporator Flow switch status	0	---	0: Ok 1: Alarm	D	R	78
---	---	Digital input 4 status	0	---	0...1	D	R	462
---	---	Evaporator pump 1 overload	0	---	0: Ok 1: Alarm	D	R	79
---	---	Digital input 12 status	0	---	0...1	D	R	451
---	---	Evaporator pump 2 overload	0	---	0: Ok 1: Alarm	D	R	80
---	---	Digital input 13 status	0	---	0...1	D	R	453
---	---	Condenser Flow switch status	0	---	0: Ok 1: Alarm	D	R	81
---	---	Digital input 5 status	0	---	0...1	D	R	463
---	---	Condenser 1 overload	0	---	0: Ok 1: Alarm	D	R	82
---	---	Digital input 8 status	0	---	0...1	D	R	469
---	---	Condenser 2 overload	0	---	0: Ok 1: Alarm	D	R	83
---	---	Digital input 11 status	0	---	0...1	D	R	450
---	---	Condenser 3 overload	0	---	0: Ok 1: Alarm	D	R	84
---	---	Digital input 8 status on Slave board	0	---	0...1	D	R	468
---	---	Condenser 4 overload	0	---	0: Ok 1: Alarm	D	R	85
---	---	Digital input 11 status on Slave board	0	---	0...1	D	R	449

Parameter code	PWD	Description	Default	UOM	Range	Type	R/W	BMS index
---	---	Remote alarm	0	---	0: Ok 1: Alarm	D	R	86
---	---	Digital input 1 status	0	---	0...1	D	R	446
---	---	Summer/Winter selection by digital input	0	---	0: Cool 1: Heat	D	R	87
---	---	Digital input 2 status	0	---	0...1	D	R	460
---	---	Remote ON/OFF	0	---	0: Off 1: On	D	R	88
---	---	Digital input 3 status	0	---	0...1	D	R	461
---	---	EVDEVO Firmware version	0.0	---	0.0...800.0	A	R	
---	---	The fw in the EVDEVO connected is not compatible with the module	0	---	0 1: Unable to connect	D	R	
---	---	The fw in the EVDEVO connected is not compatible with the module	0	---	0 1: to EVD EVO	D	R	
---	---	EVDEVO Firmware version	0.0	---	0.0...800.0	A	R	
---	---	The fw in the EVDEVO connected is not compatible with the module	0	---	0 1: Unable to connect	D	R	
---	---	The fw in the EVDEVO connected is not compatible with the module	0	---	0 1: to EVD EVO	D	R	
---	---	EVDEVO Firmware version	0.0	---	0.0...800.0	A	R	
---	---	The fw in the EVDEVO connected is not compatible with the module	0	---	0 1: Unable to connect	D	R	
---	---	The fw in the EVDEVO connected is not compatible with the module	0	---	0 1: to EVD EVO	D	R	
---	---	EVDEVO Firmware version	0.0	---	0.0...800.0	A	R	
---	---	The fw in the EVDEVO connected is not compatible with the module	0	---	0 1: Unable to connect	D	R	
---	---	The fw in the EVDEVO connected is not compatible with the module	0	---	0 1: to EVD EVO	D	R	
---	---	Major release	9	---	1...9	I	R	
---	---	Minor release	9	---	0...9	I	R	
---	---	Progressive number	0	---	0...999	I	R	
---	---	Indicates that the application is a BETA (0=Beta; 1=Official)	0	---	0: B 1: O	D	R	
---	---	Version of Demo application	0	---	0...99	I	R	
---	---	Software day	0	---	0...99	I	R	
---	---	Software month	0	---	0...99	I	R	
---	---	Software year	0	---	0...99	I	R	
---	---	High part of BIOS version number	0	---	0...9	I	R	
---	---	Low part of BIOS release version number	0	---	0...99	I	R	
---	---	BIOS day	0	---	0...99	I	R	
---	---	BIOS month	0	---	0...99	I	R	
---	---	BIOS year	0	---	0...99	I	R	
---	---	High part of boot version number	0	---	0...9	I	R	
---	---	Low part of boot version number	0	---	0...99	I	R	
---	---	Boot day	0	---	0...99	I	R	
---	---	Boot month	0	---	0...99	I	R	
---	---	Boot year	0	---	0...99	I	R	
---	---	Type of pCO controller	0	---	0: pCO2 1: pCO1 2: pCO2 3: pCOC 4: pCOxs 5: pCO OEM 6: --- 7: pCO3 8: SuperNode 9: --- 10: pCO5 11: pCOCCompact 12: pCO5+	I	R	
---	---	pCO Compact Type A	0	---	0: Type B 1: Type A	D	R	
---	---	Type of the controller	0	---	0: "" 1: "" 2: "" 3: "" 4: "" 5: "" 6: "" 7: "" 8: "" 9: "" 10: Large 11: Medium 12: Small 13: XL N.O. 14: "" 15: "" 16: "" 17: XL N.C.	I	R	
---	---	Indicates the size of the memory on the bank 0 (KB)	0	---	0...9999	I	R	
---	---	Indicates the size of the memory on the bank 1 (KB)	0	---	0...9999	I	R	
---	---	Builtin DSP	0	---	0: None 2: PGD0 3: PGD1	I	R	
---	---	Cycle X Sec	0.0	---	0.0...99.9	A	R	
---	---	Cycle Time	0	---	0...9999	I	R	

7.2 On-Off

Parameter code	PWD	Description	Default	UOM	Range	Type	R/W	BMS index
---	U	Unit status	0	---	0 1: Unit ON 2: OFF by alarm 3: OFF change-over 4: OFF BMS 5: OFF scheduler 6: OFF input 7: OFF keyboard 8: OFF change-over 9: OFF_CST1 10: OFF_CST2 11: OFF_CST3 12: OFF_CST4	I	R	432
Q001	U	Request unit On by keyboard	0	---	0..1	D	R/W	

7.3 Set

Parameter code	PWD	Description	Default	UOM	Range	Type	R/W	BMS index
Q002	U	Cooling setpoint	12.0	°C/°F	TempLowSetP_CH_Msk... TempHiSetP_CH_Msk	A	R/W	58
---	U	Summer/Winter status	0	---	0: Cool 1: Heat	D	R	441
---	U	Actual setpoint	0.0	°C/°F	0.0...999.9	A	R	27
Q003	U	Heating setpoint	40.0	°C/°F	TempLowSetP_HP_Msk... TempHiSetP_HP_Msk	A	R/W	59
---	U	Summer/Winter status	0	---	0: Cool 1: Heat	D	R	441
---	U	Actual setpoint	0.0	°C/°F	0.0...999.9	A	R	27
Q004	U	Cooling/heating (Summer/winter) by keyboard	0	---	0: COOLING 1: HEATING	D	R/W	91
---	U	Summer/Winter status	0	---	0: Cool 1: Heat	D	R	441
---	U	Actual setpoint	0.0	°C/°F	0.0...999.9	A	R	27
Q005	U	Day for BMS	0	---	1...31	I	R/W	124
Q006	U	Month for BMS	0	---	1...12	I	R/W	125
Q007	U	Year for BMS	0	---	0...99	I	R/W	126
---	U	Day of week based on current date	0	---	0: *** 1: Monday 2: Tuesday 3: Wednesday 4: Thursday 5: Friday 6: Saturday 7: Sunday	I	R	
Q008	U	Clock hour for BMS	0	---	0...23	I	R/W	122
Q009	U	Clock minute for BMS	0	---	0...59	I	R/W	123
---	U	Current language index (0=first language)	0	---	0: E 1: I 2: S	I	R/W	
---	U	Day displayed for scheduling	0	---	0: MON 1: TUE 2: WED 3: THU 4: FRI 5: SAT 6: SUN	I	R/W	
---	U	Day to overwrite for scheduling	0	---	0: MON 1: TUE 2: WED 3: THU 4: FRI 5: SAT 6: SUN	I	R/W	
---	U	Enable day scheduling copy	0	---	0: NO 1: YES	D	R/W	
---	U	Current scheduling hour (inf lim)	0	---	0...23	I	R	
---	U	Enable graphic scheduling	0	---	0 1: :	D	R	
---	U	Current scheduling minute (inf lim)	0	---	0...23	I	R	
---	U	Enable graphic scheduling	0	---	0 1: ÷	D	R	
---	U	Current scheduling hour (sup lim)	0	---	0...23	I	R	
---	U	Enable graphic scheduling	0	---	0 1: :	D	R	
---	U	Current scheduling minute (sup lim)	0	---	0...23	I	R	
---	U	Data loaded	0	---	0 1: 00-08:	D	R	
---	U	Scheduling 00:00	0	---	0...Set_Limit	I	R/W	
---	U	Scheduling 00:30	0	---	0...Set_Limit	I	R/W	
---	U	Scheduling 01:00	0	---	0...Set_Limit	I	R/W	
---	U	Scheduling 01:30	0	---	0...Set_Limit	I	R/W	
---	U	Scheduling 02:00	0	---	0...Set_Limit	I	R/W	
---	U	Scheduling 02:30	0	---	0...Set_Limit	I	R/W	
---	U	Scheduling 03:00	0	---	0...Set_Limit	I	R/W	
---	U	Scheduling 03:30	0	---	0...Set_Limit	I	R/W	
---	U	Scheduling 04:00	0	---	0...Set_Limit	I	R/W	
---	U	Scheduling 04:30	0	---	0...Set_Limit	I	R/W	
---	U	Scheduling 05:00	0	---	0...Set_Limit	I	R/W	
---	U	Scheduling 05:30	0	---	0...Set_Limit	I	R/W	
---	U	Scheduling 06:00	0	---	0...Set_Limit	I	R/W	
---	U	Scheduling 06:30	0	---	0...Set_Limit	I	R/W	

Parameter code	PWD	Description	Default	UOM	Range	Type	R/W	BMS index
---	U	Scheduling 07:00	0	---	0...Set_Limit	I	R/W	
---	U	Scheduling 07:30	0	---	0...Set_Limit	I	R/W	
---	U	Data loaded	0	---	0: LOADING... 1: --	D	R	
---	U	Data loaded	0	---	0 1: 08-16:	D	R	
---	U	Scheduling 08:00	0	---	0...Set_Limit	I	R/W	
---	U	Scheduling 08:30	0	---	0...Set_Limit	I	R/W	
---	U	Scheduling 09:00	0	---	0...Set_Limit	I	R/W	
---	U	Scheduling 09:30	0	---	0...Set_Limit	I	R/W	
---	U	Scheduling 10:00	0	---	0...Set_Limit	I	R/W	
---	U	Scheduling 10:30	0	---	0...Set_Limit	I	R/W	
---	U	Scheduling 11:00	0	---	0...Set_Limit	I	R/W	
---	U	Scheduling 11:30	0	---	0...Set_Limit	I	R/W	
---	U	Scheduling 12:00	0	---	0...Set_Limit	I	R/W	
---	U	Scheduling 12:30	0	---	0...Set_Limit	I	R/W	
---	U	Scheduling 13:00	0	---	0...Set_Limit	I	R/W	
---	U	Scheduling 13:30	0	---	0...Set_Limit	I	R/W	
---	U	Scheduling 14:00	0	---	0...Set_Limit	I	R/W	
---	U	Scheduling 14:30	0	---	0...Set_Limit	I	R/W	
---	U	Scheduling 15:00	0	---	0...Set_Limit	I	R/W	
---	U	Scheduling 15:30	0	---	0...Set_Limit	I	R/W	
---	U	Data loaded	0	---	0 1: 16-24:	D	R	
---	U	Scheduling 16:00	0	---	0...Set_Limit	I	R/W	
---	U	Scheduling 16:30	0	---	0...Set_Limit	I	R/W	
---	U	Scheduling 17:00	0	---	0...Set_Limit	I	R/W	
---	U	Scheduling 17:30	0	---	0...Set_Limit	I	R/W	
---	U	Scheduling 18:00	0	---	0...Set_Limit	I	R/W	
---	U	Scheduling 18:30	0	---	0...Set_Limit	I	R/W	
---	U	Scheduling 19:00	0	---	0...Set_Limit	I	R/W	
---	U	Scheduling 19:30	0	---	0...Set_Limit	I	R/W	
---	U	Scheduling 20:00	0	---	0...Set_Limit	I	R/W	
---	U	Scheduling 20:30	0	---	0...Set_Limit	I	R/W	
---	U	Scheduling 21:00	0	---	0...Set_Limit	I	R/W	
---	U	Scheduling 21:30	0	---	0...Set_Limit	I	R/W	
---	U	Scheduling 22:00	0	---	0...Set_Limit	I	R/W	
---	U	Scheduling 22:30	0	---	0...Set_Limit	I	R/W	
---	U	Scheduling 23:00	0	---	0...Set_Limit	I	R/W	
---	U	Scheduling 23:30	0	---	0...Set_Limit	I	R/W	

7.4 Plant

Parameter code	PWD	Description	Default	UOM	Range	Type	R/W	BMS index
---	S	Evaporator pump 1 working hours	0	x1000h	0...999	I	R	106
---	S	Evaporator pump 1 working hours	0	h	0...999	I	R	107
A001	S	Evaporator pump 1 maintenance hour threshold	99	x1000h	0...999	I	R/W	108
---	S	Reset hour counters evaporator pump 1	0	---	0: N 1: Y	D	R/W	538
---	S	Evaporator pump 1 status	0	---	0: Off 1: On	D	R	49
A002	S	Evaporator pump in manual mode	0	---	0: AUTO 1: OFF 2: ON	I	R/W	105
---	S	Evaporator pump 2 working hours	0	x1000h	0...999	I	R	109
---	S	Evaporator pump 2 working hours	0	h	0...999	I	R	110
A003	S	Evaporator pump 2 maintenance hour threshold	99	x1000h	0...999	I	R/W	111
---	S	Reset hour counters evaporator pump 2	0	---	0: N 1: Y	D	R/W	539
---	S	Evaporator pump 2 status	0	---	0: Off 1: On	D	R	50
A004	S	Switch-over evaporator pumps	0	---	0: N 1: Y	D	R/W	552
A005	S	Temperature low setpoint limits in chiller	5.0	°C/°F	-3276.8...3276.7	A	R/W	355
A006	S	Temperature high setpoint limits in chiller	20.0	°C/°F	-3276.8...3276.7	A	R/W	353
A007	S	Temperature low setpoint limits in heat pump	30.0	°C/°F	-3276.8...3276.7	A	R/W	356
A008	S	Temperature high setpoint limits in heat pump	45.0	°C/°F	-3276.8...3276.7	A	R/W	354
A009	S	Summer/winter changeover type	0	---	0: BY INPUT 1: BY KEYBOARD	D	R/W	393
A010	S	Changeover delay	60	min	0...99	I	R/W	307
A011	S	Startup regulation type	0	---	0: INLET 1: OUTLET	D	R/W	514
A012	S	Startup PID --> Run PID delay	180	s	0...9999	I	R/W	320
A013	S	Run regulation type	1	---	0: INLET 1: OUTLET	D	R/W	513
A014	S	Tau par. for exponential distribution on temp. Regulation	5	s	1...999	I	R/W	391
---	S	Reference water temperature to startup PID	0.0	°C/°F	-3276.8...3276.7	A	R	360
---	S	Temperature request by startup PID	0.0	---	0.0...100.0	A	R	325
A015	S	Startup regulation proportional band	16.0	°C/°F	-999.9...999.9	A	R/W	348
A016	S	Startup regulation integral time	180	s	0...9999	I	R/W	430
A017	S	Startup regulation derivative time	0	s	0...9999	I	R/W	429
---	S	Reference water temperature to run PID	0.0	°C/°F	-3276.8...3276.7	A	R	359
---	S	Temperature request by run PID	0.0	%	0.0...100.0	A	R	324

Parameter code	PWD	Description	Default	UOM	Range	Type	R/W	BMS index
A018	S	Run regulation proportional band	10.0	°C/°F	-999.9...999.9	A	R/W	326
A019	S	Run regulation integral time	40	s	0...9999	I	R/W	400
A020	S	Run regulation derivative time	5	s	0...9999	I	R/W	399
A021	S	Evaporator pump flow alarm startup delay	20	s	0...999	I	R/W	315
A022	S	Evaporator pump flow alarm run delay	2	s	0...999	I	R/W	314
A023	S	Delay from evaporator pump ON to start regulation	60	s	0...999	I	R/W	313
A024	S	Evaporator pump delay OFF	10	s	0...999	I	R/W	312
A025	S	Evaporator pumps rotation time	12	h	0...99	I	R/W	332
A026	S	Antifreeze alarm setpoint	4.0	°C/°F	-99.9...99.9	A	R/W	209
A027	S	Antifreeze alarm differential	2.0	°C/°F	0.0...999.9	A	R/W	208
A028	S	Antifreeze alarm threshold	-0.8	°C/°F	-999.9...999.9	A	R/W	213
A029	S	Antifreeze alarm differential	30.0	°C/°F	0.0...999.9	A	R/W	212
A030	S	Antifreeze alarm delay time at 1K below thrsh	60	s	5...300	I	R/W	213
---	S	Inlet water temperature	0.0	°C/°F	0.0...99.9	A	R	26
A031	S	Offset probe U1	0.0	°C/°F	-99.9...99.9	A	R/W	317
---	S	Outlet water temperature	0.0	°C/°F	0.0...99.9	A	R	25
A032	S	Offset probe U2	0.0	°C/°F	-99.9...99.9	A	R/W	318
A033	M	Remote alarm NO/NC contact logic	0	---	0: AL.IF OPEN 1: AL.IF CLOSE	D	R/W	515
A034	M	Remote Summer/Winter NO/NC contact logic	0	---	0: WIN.IF OPEN 1: WIN.IF CLOSE	D	R/W	516
A035	M	Remote On NO/NC contact logic	1	---	0: ON IF OPEN 1: ON IF CLOSE	D	R/W	517
A036	M	Evaporator flow switch NO/NC contact logic	0	---	0: AL.IF OPEN 1: AL.IF CLOSE	D	R/W	485
A037	M	Evaporator pump overload NO/NC contact logic	0	---	0: AL.IF OPEN 1: AL.IF CLOSE	D	R/W	486
A038	M	Digital output logic of evaporator pump	0	---	0: ON IF CLOSE 1: ON IF OPEN	D	R/W	489
A039	M	Digital output logic of general alarm	0	---	0: ON IF CLOSE 1: ON IF OPEN	D	R/W	493
A040	M	Antifreeze digital output logic	0	---	0: ON IF CLOSE 1: ON IF OPEN	D	R/W	209
A047	M	Digital output logic of Free cooling valve	0	---	0: ON IF CLOSE 1: ON IF OPEN	D	R/W	492
A045	M	Delta temp FC to activate free-cooling coil regulation	3.0	°C/°F	0.0...99.9	A	R/W	244
A046	M	Delta temp Free Cooling design (to reach unit nominal capacity)	10.0	°C/°F	0.0...999.9	A	R/W	243
A044	M	Enable Free Cooling with outdoor air (direct free-cooling)	0	---	0...1	D	R/W	481
A041	M	Antifreeze management	0	---	0: WITH HEATER 1: WITH PUMPS 2: WITH HEATER AND PUMPS	I	R/W	211
A042	M	Type of the unit	1	---	0: CHILLER ONLY 1: CHILLER/HEATPUMP 2: HEATPUMP ONLY	I	R/W	433
A043	M	Number of evaporator pumps	1	---	1...2	I	R/W	330

7.5 ExV

Parameter code	PWD	Description	Default	UOM	Range	Type	R/W	BMS index
B001	S	Manual positioning enable - Circ1	0	---	0...1	D	R/W	554
B002	S	Manual valve position - Circ1	0	---	I39_Msk_Lim_Min... I39_Msk_Lim_Max	I	R/W	448
B003	S	Manual positioning enable - Circ2	0	---	0...1	D	R/W	557
B004	S	Manual valve position - Circ2	0	---	I39_Msk_Lim_Min... I39_Msk_Lim_Max	I	R/W	461
B055	S	Manual positioning enable - Circ3	0	---	0...1	D	R/W	490
B056	S	Manual valve position - Circ3	0	---	I39_Msk_Lim_Min... I39_Msk_Lim_Max	I	R/W	333
B057	S	Manual positioning enable - Circ4	0	---	0...1	D	R/W	491
B058	S	Manual valve position - Circ4	0	---	I39_Msk_Lim_Min... I39_Msk_Lim_Max	I	R/W	335
B005	S	SuperHeat setpoint in Chiller mode	8.0	°C/°F	A50_Msk_Lim_Min... A50_Msk_Lim_Max	A	R/W	343
B006	S	Proportional gain SH regulation in chiller mode	15.0	---	A48_Msk_Lim_Min... A48_Msk_Lim_Max	A	R/W	312
B007	S	Integral time SH regulation in chiller mode	150	s	I38_Msk_Lim_Min... I38_Msk_Lim_Max	I	R/W	378
B008	S	Derivative time SH regulation in chiller mode	5.0	s	A49_Msk_Lim_Min... A49_Msk_Lim_Max	A	R/W	314
B009	S	SuperHeat setpoint in HeatPump mode	8.0	°C/°F	A50_Msk_Lim_Min... A50_Msk_Lim_Max	A	R/W	344
B010	S	Proportional gain SH regulation in heating mode	15.0	---	A48_Msk_Lim_Min... A48_Msk_Lim_Max	A	R/W	313
B011	S	Integral time SH regulation in heating mode	150	s	I38_Msk_Lim_Min... I38_Msk_Lim_Max	I	R/W	379
B012	S	Derivative time SH regulation in heating mode	5.0	s	A49_Msk_Lim_Min... A49_Msk_Lim_Max	A	R/W	315
B013	S	EEV Low SuperHeating threshold in Chiller mode	2.0	°C/°F	A56_Msk_Lim_Min... A56_Msk_Lim_Max	A	R/W	302
B014	S	Integral time Low SH in chiller mode	15.0	s	A55_Msk_Lim_Min... A55_Msk_Lim_Max	A	R/W	304
B015	S	EEV Low SuperHeating threshold in HeatPump mode	2.0	°C/°F	A56_Msk_Lim_Min... A56_Msk_Lim_Max	A	R/W	303
B016	S	Integral time Low SH in heating mode	15.0	s	A55_Msk_Lim_Min... A55_Msk_Lim_Max	A	R/W	305
B017	S	EEV Low evaporating temp. threshold in Chiller mode	-50.0	°C/°F	A52_Msk_Lim_Min... A52_Msk_Lim_Max	A	R/W	298

Parameter code	PWD	Description	Default	UOM	Range	Type	R/W	BMS index
B018	S	Integral time LOP regulation in chiller mode	15.0	s	A92_Msk_Lim_Min... A92_Msk_Lim_Max	A	R/W	300
B019	S	EEV Low evaporating temp. threshold in HeatPump mode	-50.0	°C/°F	A52_Msk_Lim_Min... A52_Msk_Lim_Max	A	R/W	299
B020	S	Integral time LOP regulation in heating mode	15.0	s	A92_Msk_Lim_Min... A92_Msk_Lim_Max	A	R/W	301
B021	S	EEV High evaporating temp. threshold in Chiller mode	20.0	°C/°F	A54_Msk_Lim_Min... A54_Msk_Lim_Max	A	R/W	308
B022	S	Integral time MOP regulation in chiller mode	20.0	s	A94_Msk_Lim_Min... A94_Msk_Lim_Max	A	R/W	310
B023	S	EEV High evaporating temp. threshold in HeatPump mode	20.0	°C/°F	A54_Msk_Lim_Min... A54_Msk_Lim_Max	A	R/W	309
B024	S	Integral time MOP regulation in heating mode	20.0	s	A94_Msk_Lim_Min... A94_Msk_Lim_Max	A	R/W	311
B025	S	LowSH: low superheat alarm delay	300	---	I43_Msk_Lim_Min... I43_Msk_Lim_Max	I	R/W	452
B026	S	Low evaporation temperature alarm delay	300	---	I41_Msk_Lim_Min... I41_Msk_Lim_Max	I	R/W	450
B027	S	MOP: high temperature evaporation alarm delay	600	---	I42_Msk_Lim_Min... I42_Msk_Lim_Max	I	R/W	451
B028	S	EEV: High condensing temperature threshold	0.0	°C/°F	A58_Msk_Lim_Min... A58_Msk_Lim_Max	A	R/W	293
B029	S	High condensing temperature: integral time	777.7	---	A57_Msk_Lim_Min... A57_Msk_Lim_Max	A	R/W	363
B030	S	High condensing temperature alarm delay	600	---	I44_Msk_Lim_Min... I44_Msk_Lim_Max	I	R/W	453
B031	S	EEV: Low suction temperature threshold	0.0	°C/°F	A26_Msk_Lim_Min... A26_Msk_Lim_Max	A	R/W	306
B032	S	Alarm delay low suction temperature	300	---	I9_Msk_Lim_Min... I9_Msk_Lim_Max	I	R/W	455
B033	S	Startup valve opening % (capacity ratio EVAP / EEV) - Chiller mode	80	%	I60_Msk_Lim_Min... I60_Msk_Lim_Max	I	R/W	417
B034	S	Startup valve opening % (capacity ratio EVAP / EEV) - HeatPump mode	75	%	I60_Msk_Lim_Min... I60_Msk_Lim_Max	I	R/W	418
B035	S	Pumpdown end evaporation temperature threshold	-11.0	°C/°F	-999.9...999.9	A	R/W	316
B036	S	Maximum pumpdown time	20	s	0...999	I	R/W	380
B037	S	Pumpdown type	0	---	0: AT START 1: AT STOP 2: AT START & STOP	I	R/W	381
B038	M	Enable liquid solenoid valve	1	---	0...1	D	R/W	484
B039	M	Pumpdown valve configuration	3	---	0: NO PUMP-DOWN 1: SOLENOID VALVE ONLY 2: ExV ONLY 3: SOLENOID AND ExV	I	R/W	382
B040	M	Regulation delay after power-on	6	---	I90_Msk_Lim_Min... I90_Msk_Lim_Max	I	R/W	456
B041	M	Output relay configuration	2	---	0: --- 1: DISABLED 2: ALARM RELAY 3: SOLENOID VALVE RELAY 4: VALVE + ALARM RELAY 5: REVERSED ALARM RELAY 6: VALVE POSITION RELAY	I	R/W	438
B042	M	Digital output logic of solenoid valve	0	---	0: ON IF CLOSE 1: ON IF OPEN	D	R/W	550
B043	M	Valve type	1	---	0: USER DEFINED 1: CAREL EXV 2: ALCO EX4 3: ALCO EX5 4: ALCO EX6 5: ALCO EX7 6: ALCO EX8 330HZ CAREL RECOMMENDED 7: ALCO EX8 500HZ ALCO SPECIFICATION 8: SPORLAN SEI 0.5-11 9: SPORLAN SER 1.5-20 10: SPORLAN SEI 30 11: SPORLAN SEI 50 12: SPORLAN SEH 100 13: SPORLAN SEH 175 14: Danfoss ETS 12.5 - 25B 15: DANFOSS ETS 50B 16: DANFOSS ETS 100B 17: DANFOSS ETS 250 18: DANFOSS ETS 400 19: TWO CAREL ExV CONNECT. TOGETHER 20: SPORLAN SER(I) G, J, K 21: DANFOSS CCM 10-20-30 22: DANFOSS CCM 40	I	R/W	439
B044	M	Regulation type	1	---	0: USER DEFINED 1: CENTRALIZED CABINET COLD ROOM 2: SELF CONTAINED CABINETCOLD ROOM 3: PERTURBATED CABINET COLD ROOM 4: SUBCRITICAL CO2 CABINET/COLD ROOM 5: R404A CONDENSER FOR SUBCRITICAL CO2 6: AC OR CHILLER WITH PLATE EVAPORATOR 7: AC OR CHILLER WITH SHELL TUBE EVAPORATOR 8: AC OR CHILLER WITH BATTERY COIL EVAPOR. 9: AC OR CHILLER WITH VAR. COOLING CAPACITY 10: AC OR CHILLER	I	R/W	440

Parameter code	PWD	Description	Default	UOM	Range	Type	R/W	BMS index
					PERTURBATED UNIT 11: UNAVAILABLE 1 12: UNAVAILABLE 2 13: UNAVAILABLE 3 14: UNAVAILABLE 4 15: UNAVAILABLE 5 16: UNAVAILABLE 6 17: UNAVAILABLE 7 18: AC/CHILLER WITH DIG. SCROLL COMPRESSOR 19: AC/CHILLER WITH BLDC COMPRESSOR 20: SH REGULATION WITH 2 TEMP. PROBES 21: pCO I/O EXPANDER			
B045	M	EEV minimum steps	50	---	I30_Msk_Lim_Min... I30_Msk_Lim_Max	I	R/W	441
B046	M	EEV maximum steps	480	---	I31_Msk_Lim_Min... I31_Msk_Lim_Max	I	R/W	442
B047	M	EEV full close steps	500	---	I36_Msk_Lim_Min... I36_Msk_Lim_Max	I	R/W	447
B048	M	EEV move rate	50	---	I32_Msk_Lim_Min... I32_Msk_Lim_Max	I	R/W	443
B049	M	Rate for fast valve closig (in case of power failure)	150	---	I86_Msk_Lim_Min... I86_Msk_Lim_Max	I	R/W	454
B050	M	EEV move current	450	---	I33_Msk_Lim_Min... I33_Msk_Lim_Max	I	R/W	444
B051	M	EEV hold current	100	---	I35_Msk_Lim_Min... I35_Msk_Lim_Max	I	R/W	446
B052	M	EEV duty cycle	30	---	I34_Msk_Lim_Min... I34_Msk_Lim_Max	I	R/W	445
B053	M	Opening valve position synchronization	1	---	0...1	D	R/W	556
B054	M	Closing valve position synchronization	1	---	0...1	D	R/W	555

7.6 Condenser

Parameter code	PWD	Description	Default	UOM	Range	Type	R/W	BMS index
---	S	Condenser pump 1 working hours	0	x1000h	0...999	I	R	113
---	S	Condenser pump 1 working hours	0	h	0...999	I	R	114
C001	S	Condenser pump 1 maintenance hour threshold	99	x1000h	0...999	I	R/W	115
---	S	Reset hour counters condenser pump 1	0	---	0: N 1: Y	D	R/W	536
---	S	Condenser pump 1 status	0	---	0: Off 1: On	D	R	439
C002	S	Condenser pump in manual mode	0	---	0: AUTO 1: OFF 2: ON	I	R/W	112
---	S	Condenser pump 2 working hours	0	x1000h	0...999	I	R	116
---	S	Condenser pump 2 working hours	0	h	0...999	I	R	117
C003	S	Condenser pump 2 maintenance hour threshold	99	x1000h	0...999	I	R/W	118
---	S	Reset hour counters condenser pump 2	0	---	0: N 1: Y	D	R/W	537
---	S	Condenser pump 2 status	0	---	0: Off 1: On	D	R	440
C004	S	Switch-over condenser pumps	0	---	0: N 1: Y	D	R/W	551
---	S	Condenser fan 1 circuit 1 working hours	0	x1000h	0...999	I	R	57
---	S	Condenser fan 1 circuit 1 working hours	0	h	0...999	I	R	62
C005	S	Circuit 1 condenser fan 1 maintenance hour threshold	99	x1000h	0...999	I	R/W	65
---	S	Reset hour counters circuit 1 condenser fan 1	0	---	0: N 1: Y	D	R/W	524
---	S	Condenser fan 1 output request circuit 1	13.0	%	0.0...999.9	A	R	9
C006	S	Condenser Fan manual command circuit 1	0	%	0: AUTO 1: 000% 2: 001% 3: 002% 4: 003% ... 98: 097% 99: 098% 100: 099% 101: 100%	I	R/W	53
---	S	Condenser fan1 circuit 2 working hours	0	x1000h	0...999	I	R	58
---	S	Condenser fan 1 circuit 2 working hours	0	h	0...999	I	R	61
C007	S	Circuit 2 condenser fan 1 maintenance hour threshold	99	x1000h	0...999	I	R/W	66
---	S	Reset hour counters circuit 2 condenser fan 1	0	---	0: N 1: Y	D	R/W	525
---	S	Condenser fan output request circuit 2	13.0	%	0.0...999.9	A	R	10
C008	S	Condenser Fan manual command circuit 2	0	%	0: AUTO 1: 000% 2: 001% 3: 002% 4: 003% ... 98: 097% 99: 098% 100: 099% 101: 100%	I	R/W	54
---	S	Condenser fan 1 circuit 3 working hours	0	x1000h	0...999	I	R	60
---	S	Condenser fan 1 circuit 3 working hours	0	h	0...999	I	R	64
C049	S	Circuit 3 condenser fan1 maintenance hour	99	x1000h	0...999	I	R/W	68

Parameter code	PWD	Description	Default	UOM	Range	Type	R/W	BMS index
		threshold						
---	S	Reset hour counters circuit 3 condenser fan 1	0	---	0: N 1: Y	D	R/W	526
---	S	Condenser fan output request circuit 3	13.0	%	0.0..999.9	A	R	12
C050	S	Condenser Fan manual command circuit 3	0	%	0: AUTO 1: 000% 2: 001% 3: 002% 4: 003% ... 98: 097% 99: 098% 100: 099% 101: 100%	I	R/W	56
---	S	Condenser fan 1 circuit 4 working hours	0	x1000h	0..999	I	R	59
---	S	Condenser fan 1 circuit 4 working hours	0	h	0..999	I	R	63
C051	S	Circuit 4 condenser fan 1 maintenance hour threshold	99	x1000h	0..999	I	R/W	67
---	S	Reset hour counters circuit 4 condenser fan 1	0	---	0: N 1: Y	D	R/W	527
---	S	Condenser fan output request circuit 4	13.0	%	0.0..999.9	A	R	11
C052	S	Condenser Fan manual command circuit 4	0	%	0: AUTO 1: 000% 2: 001% 3: 002% 4: 003% ... 98: 097% 99: 098% 100: 099% 101: 100%	I	R/W	55
---	S	Condenser fan 1 circuit 1 working hours	0	x1000h	0..999	I	R	57
---	S	Condenser fan 1 circuit 1 working hours	0	h	0..999	I	R	62
C005	S	Circuit 1 condenser fan 1 maintenance hour threshold	99	x1000h	0..999	I	R/W	65
---	S	Reset hour counters circuit 1 condenser fan 1	0	---	0: N 1: Y	D	R/W	524
---	S	Condenser fan 1 status circuit 1	0	---	0: Off 1: On	D	R	423
C053	S	Condenser Fan 1 manual command circuit 1	0	---	0: AUTO 1: OFF 2: ON	I	R/W	69
---	S	Condenser fan 2 circuit 1 working hours	0	x1000h	0..999	I	R	77
---	S	Condenser fan 2 circuit 1 working hours	0	h	0..999	I	R	81
C054	S	Circuit 1 condenser fan 2 maintenance hour threshold	99	x1000h	0..999	I	R/W	85
---	S	Reset hour counters circuit 1 condenser fan 2	0	---	0: N 1: Y	D	R/W	528
---	S	Condenser fan 2 status circuit 1	0	---	0: Off 1: On	D	R	41
C055	S	Condenser Fan 2 manual command circuit 1	0	---	0: AUTO 1: OFF 2: ON	I	R/W	73
---	S	Condenser fan 3 circuit 1 working hours	0	x1000h	0..999	I	R	93
---	S	Condenser fan 3 circuit 1 working hours	0	h	0..999	I	R	97
C056	S	Circuit 1 condenser fan 3 maintenance hour threshold	99	x1000h	0..999	I	R/W	101
---	S	Reset hour counters circuit 1 condenser fan 3	0	---	0: N 1: Y	D	R/W	532
---	S	Condenser fan 3 status circuit 1	0	---	0: Off 1: On	D	R	45
C057	S	Condenser Fan 3 manual command circuit 1	0	---	0: AUTO 1: OFF 2: ON	I	R/W	89
---	S	Condenser fan1 circuit 2 working hours	0	x1000h	0..999	I	R	58
---	S	Condenser fan 1 circuit 2 working hours	0	h	0..999	I	R	61
C007	S	Circuit 2 condenser fan 1 maintenance hour threshold	99	x1000h	0..999	I	R/W	66
---	S	Reset hour counters circuit 2 condenser fan 1	0	---	0: N 1: Y	D	R/W	525
---	S	Condenser fan 1 status circuit 2	0	---	0: Off 1: On	D	R	424
C058	S	Condenser Fan 1 manual command circuit 2	0	---	0: AUTO 1: OFF 2: ON	I	R/W	70
---	S	Condenser fan 2 circuit 2 working hours	0	x1000h	0..999	I	R	78
---	S	Condenser fan 2 circuit 2 working hours	0	h	0..999	I	R	82
C059	S	Circuit 2 condenser fan 2 maintenance hour threshold	99	x1000h	0..999	I	R/W	86
---	S	Reset hour counters circuit 2 condenser fan 2	0	---	0: N 1: Y	D	R/W	529
---	S	Condenser fan 2 status circuit 2	0	---	0: Off 1: On	D	R	42
C060	S	Condenser Fan 2 manual command circuit 2	0	---	0: AUTO 1: OFF 2: ON	I	R/W	74
---	S	Condenser fan 3 circuit 2 working hours	0	x1000h	0..999	I	R	94
---	S	Condenser fan 3 circuit 2 working hours	0	h	0..999	I	R	98
C061	S	Circuit 2 condenser fan 3 maintenance hour threshold	99	x1000h	0..999	I	R/W	102
---	S	Reset hour counters circuit 2 condenser fan 3	0	---	0: N 1: Y	D	R/W	533
---	S	Condenser fan 3 status circuit 2	0	---	0: Off 1: On	D	R	46
C062	S	Condenser Fan 3 manual command circuit 2	0	---	0: AUTO 1: OFF 2: ON	I	R/W	90

Parameter code	PWD	Description	Default	UOM	Range	Type	R/W	BMS index
---	S	Condenser fan 1 circuit 3 working hours	0	x1000h	0...999	I	R	60
---	S	Condenser fan 1 circuit 3 working hours	0	h	0...999	I	R	64
C049	S	Circuit 3 condenser fan1 maintenance hour threshold	99	x1000h	0...999	I	R/W	68
---	S	Reset hour counters circuit 3 condenser fan 1	0	---	0: N 1: Y	D	R/W	526
---	S	Condenser fan 1 status circuit 3	0	---	0: Off 1: On	D	R	425
C063	S	Condenser Fan 1 manual command circuit 3	0	---	0: AUTO 1: OFF 2: ON	I	R/W	71
---	S	Condenser fan 2 circuit 3 working hours	0	x1000h	0...999	I	R	79
---	S	Condenser fan 2 circuit 3 working hours	0	h	0...999	I	R	83
C064	S	Circuit 3 condenser fan 2 maintenance hour threshold	99	x1000h	0...999	I	R/W	87
---	S	Reset hour counters circuit 3 condenser fan 2	0	---	0: N 1: Y	D	R/W	530
---	S	Condenser fan 2 status circuit 3	0	---	0: Off 1: On	D	R	43
C065	S	Condenser Fan 2 manual command circuit 3	0	---	0: AUTO 1: OFF 2: ON	I	R/W	75
---	S	Condenser fan 3 circuit 3 working hours	0	x1000h	0...999	I	R	95
---	S	Condenser fan 3 circuit 3 working hours	0	h	0...999	I	R	99
C066	S	Circuit 3 condenser fan 3 maintenance hour threshold	99	x1000h	0...999	I	R/W	103
---	S	Reset hour counters circuit 3 condenser fan 3	0	---	0: N 1: Y	D	R/W	534
---	S	Condenser fan 3 status circuit 3	0	---	0: Off 1: On	D	R	47
C067	S	Condenser Fan 3 manual command circuit 3	0	---	0: AUTO 1: OFF 2: ON	I	R/W	91
---	S	Condenser fan 1 circuit 4 working hours	0	x1000h	0...999	I	R	59
---	S	Condenser fan 1 circuit 4 working hours	0	h	0...999	I	R	63
C051	S	Circuit 4 condenser fan 1 maintenance hour threshold	99	x1000h	0...999	I	R/W	67
---	S	Reset hour counters circuit 4 condenser fan 1	0	---	0: N 1: Y	D	R/W	527
---	S	Condenser fan 1 status circuit 4	0	---	0: Off 1: On	D	R	426
C068	S	Condenser Fan 1 manual command circuit 4	0	---	0: AUTO 1: OFF 2: ON	I	R/W	72
---	S	Condenser fan 2 circuit 4 working hours	0	x1000h	0...999	I	R	80
---	S	Condenser fan 2 circuit 4 working hours	0	h	0...999	I	R	84
C069	S	Circuit 4 condenser fan 2 maintenance hour threshold	99	x1000h	0...999	I	R/W	88
---	S	Reset hour counters circuit 4 condenser fan 2	0	---	0: N 1: Y	D	R/W	531
---	S	Condenser fan 2 status circuit 4	0	---	0: Off 1: On	D	R	44
C070	S	Condenser Fan 2 manual command circuit 4	0	---	0: AUTO 1: OFF 2: ON	I	R/W	76
---	S	Condenser fan 3 circuit 4 working hours	0	x1000h	0...999	I	R	96
---	S	Condenser fan 3 circuit 4 working hours	0	h	0...999	I	R	100
C071	S	Circuit 4 condenser fan 3 maintenance hour threshold	99	x1000h	0...999	I	R/W	104
---	S	Reset hour counters circuit 4 condenser fan 3	0	---	0: N 1: Y	D	R/W	535
---	S	Condenser fan 3 status circuit 4	0	---	0: Off 1: On	D	R	48
C072	S	Condenser Fan 3 manual command circuit 4	0	---	0: AUTO 1: OFF 2: ON	I	R/W	92
C076	S	Fan temperature threshold cold climates	-5.0	°C	-99.9...99.9	A	R/W	
C077	S	Minimum speed cold climates condenser fan	10	%	0... CondFanMinSpeed	I	R/W	
C078	S	Speed up speed cold climates condenser fan	50	%	0...100	I	R/W	
C079	S	Speed up time cold climates condenser fan	5	s	0...999	I	R/W	
C009	S	Condenser pump flow alarm startup delay	15	s	0...999	I	R/W	311
C010	S	Condenser pump flow alarm run delay	3	s	0...999	I	R/W	310
C011	S	Delay from Condenser pump ON to start regulation	30	s	0...999	I	R/W	309
C012	S	Condenser pump delay OFF	10	s	0...999	I	R/W	308
C013	S	Condenser pumps rotation time	12	h	1...99	I	R/W	280
C014	S	Condenser fan setpoint in chiller mode	23.0	°C/°F	-999.9...999.9	A	R/W	232
C015	S	Condenser setpoint offset	5.0	°C/°F	0.0...999.9	A	R/W	236
C016	S	Condenser fan setpoint at startup in chiller mode	45.0	°C/°F	-999.9...999.9	A	R/W	234
C017	S	Condenser fan startup delay in chiller mode	240	s	30...600	I	R/W	277
C018	S	Condenser fan differential in chiller mode	15.0	°C/°F	0.0...999.9	A	R/W	220
C073	S	Fan differential Chiller mode	50	%	0...100	I	R/W	286
C019	S	Condenser fan setpoint in heatpump mode	12.0	°C/°F	-999.9...999.9	A	R/W	233
C020	S	Evaporator setpoint offset	3.0	°C/°F	0.0...999.9	A	R/W	285
C021	S	Condenser fan differential in heatpump mode	5.0	°C/°F	0.0...999.9	A	R/W	221
C074	S	Fan differential Heat Pump mode	60	%	0...100	I	R/W	287
C022	S	Condenser fan minimum speed	2.0	V	0.0...10.0	A	R/W	223
C023	S	Condenser fan maximum speed	8.0	V	4.0...10.0	A	R/W	222
C024	S	Defrost start threshold	-1.0	°C/°F	-99.9...999.9	A	R/W	345
C025	S	Defrost start threshold reset	1.0	°C/°F	StartDfrThrsh_Msk...999.9	A	R/W	346
C026	S	Defrost end threshold	52.0	°C/°F	-99.9...999.9	A	R/W	254
C027	S	Reverse cycle time	20	s	0...999	I	R/W	396

Parameter code	PWD	Description	Default	UOM	Range	Type	R/W	BMS index
C028	S	Compressor power on defrost entering	50.0	%	0.0...100.0	A	R/W	215
C029	S	Compressor power on defrost exiting	0.0	%	0.0...100.0	A	R/W	216
C030	S	Defrost startup delay	300	s	1...9999	I	R/W	291
C031	S	Defrost minimum time	1	min	0...999	I	R/W	286
C032	S	Defrost maximum time	5	min	1...999	I	R/W	285
C033	S	Dripping time	30	s	0...999	I	R/W	294
C034	S	Post dripping time	30	s	0...999	I	R/W	383
C035	S	Defrost interval time	20	min	0...999	I	R/W	284
C036	S	Defrost synchronization type	0	---	0: INDIPENDENT 1: SEPARATED 2: SIMULTANEOUS	I	R/W	292
C037	S	Antifreeze condenser alarm threshold	-1.5	°C/°F	-999.9...999.9	A	R/W	211
C038	S	Antifreeze condenser alarm differential	30.0	°C/°F	0.0...999.9	A	R/W	210
C039	S	Antifreeze condenser alarm delay time at 1K below thrsh	60	s	5...300	I	R/W	212
---	S	External temperature	0.0	°C/°F	0.0...99.9	A	R	57
C040	S	Offset probe U3	0.0	°C/°F	-99.9...99.9	A	R/W	319
---	S	External temperature	0.0	°C/°F	0.0...99.9	A	R	57
C040	S	Offset probe U3	0.0	°C/°F	-99.9...99.9	A	R/W	319
C042	M	Condenser fan/pump overload NO/NC contact logic	0	---	0: AL.IF OPEN 1: AL.IF CLOSE	D	R/W	438
C043	M	Condenser flow switch NO/NC contact logic	0	---	0: AL.IF OPEN 1: AL.IF CLOSE	D	R/W	436
C044	M	Digital output logic of condenser fan	0	---	0: ON IF CLOSE 1: ON IF OPEN	D	R/W	437
C075	M	Fans number	1	---	1...3	I	R/W	357
C045	M	Number of condenser pumps	1	---	1...2	I	R/W	278
C046	M	Condenser fan type	1	---	0: ON-OFF FAN 1: ENABLE INVERTER	D	R/W	435
C048	M	Air circuit type	1	---	0: COMMON 1: INDIPENDENT	D	R/W	210
C047	M	Water/Water unit	0	---	0: AIR/WATER 1: WATER/WATER	D	R/W	553

7.7 Compressor

Parameter code	PWD	Description	Default	UOM	Range	Type	R/W	BMS index
---	S	Compressor 1 circuit 1 working hours	0	x1000h	0...999	I	R	25
---	S	Compressor 1 circuit 1 working hours	0	h	0...999	I	R	29
Da01	S	Compressor 1 hour threshold	30	x1000h	0...999	I	R/W	33
---	S	Reset hour counters compressor 1 circuit 1	0	---	0: N 1: Y	D	R/W	520
---	S	Compressor 1 running power circuit 1	0	%	0...999	I	R	1
Da02	S	Compressor 1 manual control circuit 1	0	%	0: AUTO 1: 000% 2: 001% 3: 002% 4: 003% ... 98: 097% 99: 098% 100: 099% 101: 100%	I	R/W	21
---	S	Compressor 1 circuit 2 working hours	0	x1000h	0...999	I	R	26
---	S	Compressor 1 circuit 2 working hours	0	h	0...999	I	R	30
Da03	S	Compressor 2 hour threshold	30	x1000h	0...999	I	R/W	34
---	S	Reset hour counters compressor 1 circuit 2	0	---	0: N 1: Y	D	R/W	521
---	S	Compressor 1 running power circuit 2	0	%	0...999	I	R	2
Da04	S	Compressor 1 manual control circuit 2	0	%	0: AUTO 1: 000% 2: 001% 3: 002% 4: 003% ... 98: 097% 99: 098% 100: 099% 101: 100%	I	R/W	22
---	S	Compressor 1 circuit 3 working hours	0	x1000h	0...999	I	R	28
---	S	Compressor 1 circuit 3 working hours	0	h	0...999	I	R	32
Da85	S	Compressor 3 hour threshold	30	x1000h	0...999	I	R/W	36
---	S	Reset hour counters compressor 1 circuit 3	0	---	0: N 1: Y	D	R/W	522
---	S	Compressor 1 running power circuit 3	0	%	0...999	I	R	4
Da86	S	Compressor 1 manual control circuit 3	0	%	0: AUTO 1: 000% 2: 001% 3: 002% 4: 003% ... 98: 097% 99: 098% 100: 099% 101: 100%	I	R/W	24
---	S	Compressor 1 circuit 4 working hours	0	x1000h	0...999	I	R	27
---	S	Compressor 1 circuit 4 working hours	0	h	0...999	I	R	31
Da87	S	Compressor 4 hour threshold	30	x1000h	0...999	I	R/W	35

Parameter code	PWD	Description	Default	UOM	Range	Type	R/W	BMS index
---	S	Reset hour counters compressor 1 circuit 4	0	---	0: N 1: Y	D	R/W	523
---	S	Compressor 1 running power circuit 4	0	%	0...999	I	R	3
Da88	S	Compressor 1 manual control circuit 4	0	%	0: AUTO 1: 000% 2: 001% 3: 002% 4: 003% ... 98: 097% 99: 098% 100: 099% 101: 100%	I	R/W	23
Da05	S	Min time OFF compressor	180	s	MinMinOffT...999	I	R/W	353
Da06	S	Min time OFF compressor after alarm	180	s	0...999	I	R/W	352
Da07	S	Min time ON compressor	300	s	MinMinOnT...999	I	R/W	355
Da08	S	Min time between ON of the same compressor	600	s	MinMinOnOnSameT...999	I	R/W	354
Da09	S	Compressor load up time	300	s	0...999	I	R/W	342
Da10	S	Compressor load down time	30	s	0...999	I	R/W	340
Da11	S	Force rotation interval time	2	h	0...9	I	R/W	337
Da99	S	Delay between steps activation	20	s	0...999	I	R/W	341
Da12	S	Evaporating minimum temperature envelop limit	-20.0	°C/°F	-999.9...999.9	A	R/W	284
Da13	S	Condensing maximum temperature envelop limit	65.0	°C/°F	-999.9...999.9	A	R/W	235
Da14	S	Low pressure alarm startup delay	40	s	0...999	I	R/W	317
Da15	S	Low pressure alarm run delay	10	s	0...999	I	R/W	316
Da16	S	Oil level alarm startup delay	30	s	0...999	I	R/W	319
Da17	S	Oil level alarm run delay	15	s	0...999	I	R/W	318
Da18	S	High discharge pressure delay	40	s	0...999	I	R/W	296
Da19	S	High current alarm delay	20	s	0...999	I	R/W	295
Da20	S	High suction pressure alarm startup delay	120	s	0...999	I	R/W	298
Da21	S	High suction pressure alarm run delay	60	s	0...999	I	R/W	297
Da22	S	Low pressure ratio alarm startup delay	60	s	0...999	I	R/W	304
Da23	S	Low pressure ratio alarm run delay	20	s	0...999	I	R/W	303
Da24	S	Low delta pressure alarm startup delay	45	s	0...999	I	R/W	300
Da25	S	Low delta pressure alarm run delay	20	s	0...999	I	R/W	299
Da26	S	Low discharge pressure alarm startup delay	180	s	0...999	I	R/W	302
Da27	S	Low discharge pressure alarm run delay	60	s	0...999	I	R/W	301
Da28	S	Low suction pressure alarm startup delay	180	s	0...999	I	R/W	306
Da29	S	Low suction pressure alarm run delay	60	s	0...999	I	R/W	305
Da30	S	Max retry per hour for low suction pressure alarm	3	---	1...9	I	R/W	348
Da31	S	Prevent time for compressor step	30	s	0...32767	I	R/W	387
Da32	M	Pulsing valve Min time OFF	3	s	2...999	I	R/W	437
Da33	M	Pulsing valve Max time OFF	12	s	VlvPlsOffT_Min...999	I	R/W	436
Da34	M	Eco temperature setpoint	45.0	°C/°F	-999.9...999.9	A	R/W	253
Da35	M	Eco temperature differential	3.0	°C/°F	0.0...999.9	A	R/W	252
Da36	M	Eco minimum compressor power	75.0	%	0.0...100.0	A	R/W	251
Da37	M	Liquid injection temperature setpoint	100.0	°C/°F	-999.9...999.9	A	R/W	297
Da38	M	Liquid injection differential	10.0	°C/°F	0.0...999.9	A	R/W	296
Da2A	M	Value of delta pressure for a correct change of the reverse valve	3.0	barg/psig	0.0...999.9	A	R/W	245
Da39	M	Compressor ignition: Winding A to B delay time	500	ms	0...32767	I	R/W	390
Da40	M	Star/delta time delay [ms]	20	ms	0...32767	I	R/W	415
Da41	M	Star relay activation time [ms]	1000	ms	0...32767	I	R/W	416
Da42	M	Ignition type	1	---	0: DIRECT START 1: PART WINDING 2: STAR-DELTA	I	R/W	339
Da43	M	Low pressure from pressostat NO/NC contact logic	0	---	0: AL.IF OPEN 1: AL.IF CLOSE	D	R/W	507
Da44	M	Oil level NO/NC contact logic	0	---	0: AL.IF OPEN 1: AL.IF CLOSE	D	R/W	508
Da45	M	High pressure from pressostat contact NO/NC logic	0	---	0: AL.IF OPEN 1: AL.IF CLOSE	D	R/W	495
Da46	M	Compressor overload contact NO/NC logic	0	---	0: AL.IF OPEN 1: AL.IF CLOSE	D	R/W	418
Da47	M	Digital output logic of 4-way valve	0	---	0: HEAT CLOSE 1: HEAT IF OPEN	D	R/W	544
Da48	M	Digital output logic of ECONomizer	0	---	0: ON IF CLOSE 1: ON IF OPEN	D	R/W	477
Da49	M	Digital output logic of Liquid injection	0	---	0: ON IF CLOSE 1: ON IF OPEN	D	R/W	506
Da50	M	Current probe type	2	---	0: 0-1V 1: 0-10V 2: 0-20mA 3: 4-20mA 4: 0-5V 5: 0.5-4.5V	I	R/W	281
Da51	M	Min value current probe	0.0	A	0.0...999.9	A	R/W	242
Da52	M	Max value current probe	50.0	A	0.0...999.9	A	R/W	241
---	S	Current compressor 1 circuit 1	0.0	A	-999.9...999.9	A	R	61
Da53	S	Offset current probe compressor 1	0.0	A	-99.9...99.9	A	R/W	237
---	S	Current compressor 1 circuit 2	0.0	A	-999.9...999.9	A	R	62
Da54	S	Offset current probe compressor 1	0.0	A	-99.9...99.9	A	R/W	238
---	S	Current compressor 1 circuit 3	0.0	A	-999.9...999.9	A	R	64
Da89	S	Offset current probe compressor 3	0.0	A	-99.9...99.9	A	R/W	239
---	S	Current compressor 1 circuit 4	0.0	A	-999.9...999.9	A	R	63
Da90	S	Offset current probe compressor 4	0.0	A	-99.9...99.9	A	R/W	240
Da55	M	Probe type suction pressure	0	---	0: RAZ. 0-5V 1: 4-20mA 2: 4-20mA REMOTE	I	R/W	457

Parameter code	PWD	Description	Default	UOM	Range	Type	R/W	BMS index
					3: 4-20mA EXTERNAL			
Da56	M	Min value suction pressure probe	0.0	barg/psig	A32_Msk_Lim_Min... A32_Msk_Lim_Max	A	R/W	350
Da57	M	Max value suction pressure probe	30.0	barg/psig	A30_Msk_Lim_Min... A30_Msk_Lim_Max	A	R/W	349
Da58	M	Probe type suction temperature	0	---	0: NTC CAREL 1: CAREL NTC-HT 2: NTC SPKP**T0 3: 0-10V EXT. SIGNAL	I	R/W	458
Da59	M	Suction temperature threshold probe low	0.0	°C/°F	-999.9...999.9	A	R/W	352
Da60	M	Suction temperature threshold probe high	0.0	°C/°F	-999.9...999.9	A	R/W	351
---	S	Suction pressure circuit 1	0.0	barg/psig	-999.9...999.9	A	R	33
Da61	S	Suction pressure circuit 1 offset	0.0	barg/psig	A34_Msk_Lim_Min... A34_Msk_Lim_Max	A	R/W	327
---	S	Suction temperature circuit 1	0.0	°C/°F	-999.9...999.9	A	R	41
Da62	S	Suction temperature circuit 1 offset	0.0	°C/°F	A41_Msk_Lim_Min... A41_Msk_Lim_Max	A	R/W	331
---	S	Suction pressure circuit 2	0.0	barg/psig	-999.9...999.9	A	R	34
Da63	S	Suction pressure circuit 2 offset	0.0	barg/psig	A34_Msk_Lim_Min... A34_Msk_Lim_Max	A	R/W	328
---	S	Suction temperature circuit 2	0.0	°C/°F	-999.9...999.9	A	R	42
Da64	S	Suction temperature circuit 2 offset	0.0	°C/°F	A41_Msk_Lim_Min... A41_Msk_Lim_Max	A	R/W	332
---	S	Suction pressure circuit 3	0.0	barg/psig	-999.9...999.9	A	R	36
Da91	S	Suction pressure circuit 3 offset	0.0	barg/psig	A34_Msk_Lim_Min... A34_Msk_Lim_Max	A	R/W	329
---	S	Suction temperature circuit 3	0.0	°C/°F	-999.9...999.9	A	R	44
Da92	S	Suction temperature circuit 3 offset	0.0	°C/°F	A41_Msk_Lim_Min... A41_Msk_Lim_Max	A	R/W	333
---	S	Suction pressure circuit 4	0.0	barg/psig	-999.9...999.9	A	R	35
Da93	S	Suction pressure circuit 4 offset	0.0	barg/psig	A34_Msk_Lim_Min... A34_Msk_Lim_Max	A	R/W	330
---	S	Suction temperature circuit 4	0.0	°C/°F	-999.9...999.9	A	R	43
Da94	S	Suction temperature circuit 4 offset	0.0	°C/°F	A41_Msk_Lim_Min... A41_Msk_Lim_Max	A	R/W	334
Da65	M	Probe type discharge pressure	0	---	0: RAZ. 0-5V 1: 4-20mA 2: 4-20mA REMOTE 3: 4-20mA EXTERNAL	I	R/W	459
Da66	M	Min value discharge pressure probe	0.0	barg/psig	A33_Msk_Lim_Min... A33_Msk_Lim_Max	A	R/W	247
Da67	M	Max value discharge pressure probe	30.0	barg/psig	A31_Msk_Lim_Min... A31_Msk_Lim_Max	A	R/W	246
Da68	M	Probe type discharge temperature	0	---	0: CAREL NTC 1: CAREL NTC-HT 2: NTC SPKP**T0	I	R/W	460
Da69	M	Discharge temperature probe min. value	0.0	°C/°F	-999.9...999.9	A	R/W	249
Da70	M	Discharge temperature probe max. value	0.0	°C/°F	-999.9...999.9	A	R/W	248
---	S	Discharge pressure circuit 1	0.0	barg/psig	-999.9...999.9	A	R	45
Da71	S	Discharge pressure circuit 1 offset	0.0	barg/psig	A35_Msk_Lim_Min... A35_Msk_Lim_Max	A	R/W	335
---	S	Discharge temperature circuit 1	0.0	°C/°F	-999.9...999.9	A	R	53
Da72	S	Discharge temperature circuit 1 offset	0.0	°C/°F	A42_Msk_Lim_Min... A42_Msk_Lim_Max	A	R/W	339
---	S	Discharge pressure circuit 2	0.0	barg/psig	-999.9...999.9	A	R	46
Da73	S	Discharge pressure circuit 2 offset	0.0	barg/psig	A35_Msk_Lim_Min... A35_Msk_Lim_Max	A	R/W	336
---	S	Discharge temperature circuit 2	0.0	°C/°F	-999.9...999.9	A	R	54
Da74	S	Discharge temperature circuit 2 offset	0.0	°C/°F	A42_Msk_Lim_Min... A42_Msk_Lim_Max	A	R/W	340
---	S	Discharge pressure circuit 3	0.0	barg/psig	-999.9...999.9	A	R	48
Da95	S	Discharge pressure circuit 3 offset	0.0	barg/psig	A35_Msk_Lim_Min... A35_Msk_Lim_Max	A	R/W	337
---	S	Discharge temperature circuit 3	0.0	°C/°F	-999.9...999.9	A	R	56
Da96	S	Discharge temperature circuit 3 offset	0.0	°C/°F	A42_Msk_Lim_Min... A42_Msk_Lim_Max	A	R/W	341
---	S	Discharge pressure circuit 4	0.0	barg/psig	-999.9...999.9	A	R	47
Da97	S	Discharge pressure circuit 4 offset	0.0	barg/psig	A35_Msk_Lim_Min... A35_Msk_Lim_Max	A	R/W	338
---	S	Discharge temperature circuit 4	0.0	°C/°F	-999.9...999.9	A	R	55
Da98	S	Discharge temperature circuit 4 offset	0.0	°C/°F	A42_Msk_Lim_Min... A42_Msk_Lim_Max	A	R/W	342
Da75	M	Rotation type	1	---	0: --- 1: FIFO 2: LIFO 3: BY TIME	I	R/W	398
Da76	M	Devices unload sequence type	1	---	0: --- 1: CCpppp 2: CppCpp	I	R/W	283
Da1A	M	Compressor maximum operating current (SETPOINT)	0.0	amp	0.0...3276.7	A	R/W	292
Da77	M	Number of circuit in the unit	1	---	1...4	I	R/W	217
Da78	M	Refrigerant type	1	---	0: R22 1: R134a 2: R404A 3: R407C 4: R410A 5: R507 6: R290 7: R600 8: R600a 9: R717 10: R744 11: R728 12: R1270 13: R417A	I	R/W	397

Parameter code	PWD	Description	Default	UOM	Range	Type	R/W	BMS index
					14: R422d 15: R413A 16: R422A 17: R423A 18: R407A 19: R427A 20: R245fa 21: R407F 22: R32			
Da79	M	Enable current probe	0	---	0...1	D	R/W	478
Da80	M	Enable envelope prevent control	1	---	0...1	D	R/W	480
Da81	M	Eco enable	0	---	0...1	D	R/W	479
Da82	M	Enable liquid injection	0	---	0...1	D	R/W	483
Da83	M	Compressor manufacturer	1	---	0: CUSTOM 1: BITZER 2: REFCOMP 3: FRASCOLD 4: HANBELL 5: FUSHENG 6: J&E HALL 7: COPELAND	I	R/W	262
Da84	M	Compressor model	1	---	0: CSH3 M1 R134a 1: CSH3 M1 50% R134a 2: CSH3 25% M1 R134a 3: CSH3 50% M1 R134a 4: CSH3 M2 R134a 5: CSH3 M2 50% R134a 6: CSH3 25% M2 R134a 7: CSH3 50% M2 R134a 8: CSH6553-8573 R407C 9: CSH6553-8573 25% R407C 10: CSH6553-8573 50% R407C 11: CSH8583/95103 R407C 12: CSH8583/95103 25% R407C 13: CSH8583/95103 50% R407C 14: CSW R134a 15: CSW 25% R134a 16: CSW 50% R134a 17: CSW R407C 18: CSW 25% R407C 19: CSW 50% R407C 20: CSVH24-125Y R134a 21: CSVH25-160Y R134a 22: CSVH26-200Y R134a	I	R/W	263
Da84	M	Compressor model	1	---	0: STEP COMPRESSOR 1: STEPLESS COMPRESSOR 2: INVERTER COMPRESSOR	I	R/W	263
Da84	M	Compressor model	1	---	0: 134-S R134a 1: 134-XS L1 R134a 2: 134-XS L2 R134a 3: 134-S R134a	I	R/W	263
Da84	M	Compressor model	1	---	0: CXH MOTOR 1 25% R134a 1: CXH MOTOR 1 50% R134a 2: CXH MOTOR 2 25% R134a 3: CXH MOTOR 2 50% R134a 4: CXH MOTOR 1 R134a 5: CXH MOTOR 2 R134a 6: CXW MOTOR 1 25% R134a 7: CXW MOTOR 1 50% R134a 8: CXW MOTOR 1 R134a 9: CXIT R134a	I	R/W	263
Da84	M	Compressor model	1	---	0: RC2-200/930 M.A R134a 1: RC2-200/930 M.B R134a 2: RC2-200/930 M.A R134a 3: RC2-200/930 M.B R134a 4: RC2-1020/1530 M.A1 R134a 5: RC2-1020/1530 M.A2 R134a 6: RC2-1020/1530 M.B1 R134a	I	R/W	263
Da84	M	Compressor model	1	---	0: SR R22 1: SR R134a 2: SR R22 3: SR R134a	I	R/W	263
---	M	Compressor type (visualization only)	0	---	0: Error configuration! 1: Step,no env.data 2: Step 3: Stepless,no env.data 4: Stepless 5: Inverter,no env.data 6: Inverter	I	R	264
---	M	Compressor model msk	1	---	0: STEP 1: STEP 2: STEPLESS 3: STEPLESS 4: STEP 5: STEP 6: STEPLESS 7: STEPLESS 8: STEP 9: STEPLESS 10: STEPLESS 11: STEP 12: STEPLESS 13: STEPLESS 14: STEP 15: STEPLESS 16: STEPLESS 17: STEP 18: STEPLESS 19: STEPLESS 20: INVERTER 21: INVERTER 22: INVERTER	I	R	

Parameter code	PWD	Description	Default	UOM	Range	Type	R/W	BMS index
---	M	Compressor model msk	1	---	0: STEP 1: STEPLESS 2: INVERTER	I	R	
---	M	Compressor model msk	1	---	0: STEP 1: STEP 2: STEP 3: STEPLESS	I	R	
---	M	Compressor model msk	1	---	0: STEP 1: STEP 2: STEP 3: STEP 4: STEPLESS 5: STEPLESS 6: STEP 7: STEP 8: STEPLESS 9: INVERTER	I	R	
---	M	Compressor model msk	1	---	0: STEPLESS 1: STEPLESS 2: STEP 3: STEP 4: STEPLESS 5: STEPLESS 6: STEPLESS	I	R	
---	M	Compressor model msk	1	---	0: STEP 1: STEP 2: STEPLESS 3: STEPLESS	I	R	
Db01	M	Valve number	1	---	1...4	I	R/W	435
Db02	M	Pulsing valve: increment pulse time	1.0	s	0.1...9.9	A	R/W	358
Db03	M	Pulsing valve: decrement pulse time	1.0	s	0.1...9.9	A	R/W	357
Db04	M	Compressor valves intermittent time	1	s	1...99	I	R/W	434
Db10	M	Compressor OFF: Valve 1 command type	1	---	0: D 1: O 2: X 3: I 4: P 5: N	I	R/W	358
Db11	M	Compressor startup phase 1: Valve 1 command type	1	---	0: D 1: O 2: X 3: I 4: P 5: N	I	R/W	419
Db13	M	Compressor phase 1: Valve 1 command type	1	---	0: D 1: O 2: X 3: I 4: P 5: N	I	R/W	362
Db14	M	Compressor phase 2: Valve 1 command type	1	---	0: D 1: O 2: X 3: I 4: P 5: N	I	R/W	366
Db15	M	Compressor phase 3: Valve 1 command type	1	---	0: D 1: O 2: X 3: I 4: P 5: N	I	R/W	370
Db16	M	Compressor phase 4: Valve 1 command type	1	---	0: D 1: O 2: X 3: I 4: P 5: N	I	R/W	374
Db17	M	Compressor shutdown phase 1: Valve 1 command type	1	---	0: D 1: O 2: X 3: I 4: P 5: N	I	R/W	401
Db20	M	Compressor OFF: Valve 2 command type	1	---	0: D 1: O 2: X 3: I 4: P 5: N	I	R/W	359
Db21	M	Compressor startup phase 1: Valve 2 command type	1	---	0: D 1: O 2: X 3: I 4: P 5: N	I	R/W	420
Db23	M	Compressor phase 1: Valve 2 command type	1	---	0: D 1: O 2: X 3: I 4: P 5: N	I	R/W	363
Db24	M	Compressor phase 2: Valve 2 command type	1	---	0: D 1: O 2: X 3: I 4: P 5: N	I	R/W	367
Db25	M	Compressor phase 3: Valve 2 command type	1	---	0: D 1: O 2: X	I	R/W	371

Parameter code	PWD	Description	Default	UOM	Range	Type	R/W	BMS index
					3: I 4: P 5: N			
Db26	M	Compressor phase 4: Valve 2 command type	1	---	0: D 1: O 2: X 3: I 4: P 5: N	I	R/W	375
Db27	M	Compressor shutdown phase 1: Valve 2 command type	1	---	0: D 1: O 2: X 3: I 4: P 5: N	I	R/W	402
Db30	M	Compressor OFF: Valve 3 command type	1	---	0: D 1: O 2: X 3: I 4: P 5: N	I	R/W	360
Db31	M	Compressor startup phase 1: Valve 3 command type	1	---	0: D; 1: O; 2: X; 3: I; 4: P; 5: N	I	R/W	421
Db33	M	Compressor phase 1: Valve 3 command type	1	---	0: D; 1: O; 2: X; 3: I; 4: P; 5: N	I	R/W	364
Db34	M	Compressor phase 2: Valve 3 command type	1	---	0: D; 1: O; 2: X; 3: I; 4: P; 5: N	I	R/W	368
Db35	M	Compressor phase 3: Valve 3 command type	1	---	0: D; 1: O; 2: X; 3: I; 4: P; 5: N	I	R/W	372
Db36	M	Compressor phase 4: Valve 3 command type	1	---	0: D; 1: O; 2: X; 3: I; 4: P; 5: N	I	R/W	376
Db37	M	Compressor shutdown phase 1: Valve 3 command type	1	---	0: D; 1: O; 2: X; 3: I; 4: P; 5: N	I	R/W	403
Db40	M	Compressor OFF: Valve 4 command type	1	---	0: D; 1: O; 2: X; 3: I; 4: P; 5: N	I	R/W	361
Db41	M	Compressor startup phase 1: Valve 4 command type	1	---	0: D; 1: O; 2: X; 3: I; 4: P; 5: N	I	R/W	422
Db43	M	Compressor phase 1: Valve 4 command type	1	---	0: D; 1: O; 2: X; 3: I; 4: P; 5: N	I	R/W	365
Db44	M	Compressor phase 2: Valve 4 command type	1	---	0: D; 1: O; 2: X; 3: I; 4: P; 5: N	I	R/W	369
Db45	M	Compressor phase 3: Valve 4 command type	1	---	0: D; 1: O; 2: X; 3: I; 4: P; 5: N	I	R/W	373
Db46	M	Compressor phase 4: Valve 4 command type	1	---	0: D; 1: O; 2: X; 3: I; 4: P; 5: N	I	R/W	377
Db47	M	Compressor shutdown phase 1: Valve 4 command type	1	---	0: D; 1: O; 2: X; 3: I; 4: P; 5: N	I	R/W	404
Db10	M	Compressor OFF: Valve 1 command type	1	---	0: D; 1: O; 2: X; 3: I; 4: P; 5: N	I	R/W	358
Db11	M	Compressor startup phase 1: Valve 1 command type	1	---	0: D; 1: O; 2: X; 3: I; 4: P; 5: N	I	R/W	419
Db12	M	Compressor startup phase 2: Valve 1 command type	1	---	0: D; 1: O; 2: X; 3: I; 4: P; 5: N	I	R/W	423
Db13	M	Compressor phase 1: Valve 1 command type	1	---	0: D; 1: O; 2: X; 3: I; 4: P; 5: N	I	R/W	362
Db14	M	Compressor phase 2: Valve 1 command type	1	---	0: D; 1: O; 2: X; 3: I; 4: P; 5: N	I	R/W	366
Db15	M	Compressor phase 3: Valve 1 command type	1	---	0: D; 1: O; 2: X; 3: I; 4: P; 5: N	I	R/W	370
Db17	M	Compressor shutdown phase 1: Valve 1 command type	1	---	0: D; 1: O; 2: X; 3: I; 4: P; 5: N	I	R/W	401
Db18	M	Compressor shutdown phase 2: Valve 1 command type	1	---	0: D; 1: O; 2: X; 3: I; 4: P; 5: N	I	R/W	405
Db20	M	Compressor OFF: Valve 2 command type	1	---	0: D; 1: O; 2: X; 3: I; 4: P; 5: N	I	R/W	359
Db21	M	Compressor startup phase 1: Valve 2 command type	1	---	0: D; 1: O; 2: X; 3: I; 4: P; 5: N	I	R/W	420
Db22	M	Compressor startup phase 2: Valve 2 command type	1	---	0: D; 1: O; 2: X; 3: I; 4: P; 5: N	I	R/W	424
Db23	M	Compressor phase 1: Valve 2 command type	1	---	0: D; 1: O; 2: X; 3: I; 4: P; 5: N	I	R/W	363
Db24	M	Compressor phase 2: Valve 2 command type	1	---	0: D; 1: O; 2: X; 3: I; 4: P; 5: N	I	R/W	367
Db25	M	Compressor phase 3: Valve 2 command type	1	---	0: D; 1: O; 2: X; 3: I; 4: P; 5: N	I	R/W	371
Db27	M	Compressor shutdown phase 1: Valve 2 command type	1	---	0: D; 1: O; 2: X; 3: I; 4: P; 5: N	I	R/W	402
Db28	M	Compressor shutdown phase 2: Valve 2 command type	1	---	0: D; 1: O; 2: X; 3: I; 4: P; 5: N	I	R/W	406
Db30	M	Compressor OFF: Valve 3 command type	1	---	0: D; 1: O; 2: X; 3: I; 4: P; 5: N	I	R/W	360
Db31	M	Compressor startup phase 1: Valve 3 command type	1	---	0: D; 1: O; 2: X; 3: I; 4: P; 5: N	I	R/W	421
Db32	M	Compressor startup phase 2: Valve 3 command type	1	---	0: D; 1: O; 2: X; 3: I; 4: P; 5: N	I	R/W	425
Db33	M	Compressor phase 1: Valve 3 command type	1	---	0: D; 1: O; 2: X; 3: I; 4: P; 5: N	I	R/W	364
Db34	M	Compressor phase 2: Valve 3 command type	1	---	0: D; 1: O; 2: X; 3: I; 4: P; 5: N	I	R/W	368
Db35	M	Compressor phase 3: Valve 3 command type	1	---	0: D; 1: O; 2: X; 3: I; 4: P; 5: N	I	R/W	372
Db37	M	Compressor shutdown phase 1: Valve 3 command type	1	---	0: D; 1: O; 2: X; 3: I; 4: P; 5: N	I	R/W	403
Db38	M	Compressor shutdown phase 2: Valve 3 command type	1	---	0: D; 1: O; 2: X; 3: I; 4: P; 5: N	I	R/W	407
Db40	M	Compressor OFF: Valve 4 command type	1	---	0: D; 1: O; 2: X; 3: I; 4: P; 5: N	I	R/W	361
Db41	M	Compressor startup phase 1: Valve 4 command type	1	---	0: D; 1: O; 2: X; 3: I; 4: P; 5: N	I	R/W	422
Db42	M	Compressor startup phase 2: Valve 4 command type	1	---	0: D; 1: O; 2: X; 3: I; 4: P; 5: N	I	R/W	426
Db43	M	Compressor phase 1: Valve 4 command type	1	---	0: D; 1: O; 2: X; 3: I; 4: P; 5: N	I	R/W	365
Db44	M	Compressor phase 2: Valve 4 command type	1	---	0: D; 1: O; 2: X; 3: I; 4: P; 5: N	I	R/W	369
Db45	M	Compressor phase 3: Valve 4 command type	1	---	0: D; 1: O; 2: X; 3: I; 4: P; 5: N	I	R/W	373
Db47	M	Compressor shutdown phase 1: Valve 4 command type	1	---	0: D; 1: O; 2: X; 3: I; 4: P; 5: N	I	R/W	404
Db48	M	Compressor shutdown phase 2: Valve 4 command type	1	---	0: D; 1: O; 2: X; 3: I; 4: P; 5: N	I	R/W	408
Db50	M	Compressor startup phase 1 time	10	s	0...9999	I	R/W	428
Db51	M	Compressor shutdown phase 1 time	10	s	0...9999	I	R/W	410
Db52	M	Start/stop power	25.0	%	0.0...100.0	A	R/W	347
Db53	M	Number of compressor steps	1	---	1...4	I	R/W	431
Db54	M	Compressor power step 1	25.0	%	0.0...100.0	A	R/W	320
Db55	M	Compressor power step 2	50.0	%	0.0...100.0	A	R/W	321
Db56	M	Compressor power step 3	75.0	%	0.0...100.0	A	R/W	322
Db57	M	Step 1 - Step 2 delay	10	s	0...9999	I	R/W	321
Db58	M	Step 2 - Step 3 delay	10	s	0...9999	I	R/W	322
Db59	M	Step 3 - Step 4 delay	10	s	0...9999	I	R/W	323
Db61	M	Compressor startup phase 2 time	0	s	0...9999	I	R/W	427
Db63	M	Compressor shutdown phase 2 time	0	s	0...9999	I	R/W	409
Db65	M	Min power of stepless compressor	25.0	%	0.0...100.0	A	R/W	307

Parameter code	PWD	Description	Default	UOM	Range	Type	R/W	BMS index
Db66	M	Min power reach time for stepless control	60	s	0...9999	I	R/W	356
Db67	M	Max power reach time for stepless control	60	s	0...9999	I	R/W	347
Db68	M	MinInputValue of Min time OFF compressor	60	s	0...999	I	R/W	349
Db69	M	MinInputValue of Min time ON compressor	240	s	0...999	I	R/W	351
Db70	M	MinInputValue of Min time between ON of the same compressor	360	s	0...999	I	R/W	350
Db71	M	Envelope condensing min temperature	0.0	°C/°F	-999.9...999.9	A	R/W	257
Db72	M	Envelope condensing max temperature	0.0	°C/°F	-999.9...999.9	A	R/W	255
Db73	M	Envelope evaporating min temperature	0.0	°C/°F	-999.9...999.9	A	R/W	262
Db74	M	Envelope evaporating max temperature	0.0	°C/°F	-999.9...999.9	A	R/W	260
Db75	M	Envelope max condensing temperature in Eco mode	0.0	°C/°F	-999.9...999.9	A	R/W	256
Db76	M	Envelope max evaporating temperature in Eco mode	0.0	°C/°F	-999.9...999.9	A	R/W	261
Db77	M	Envelope max current segment X1	0.0	°C/°F	-999.9...999.9	A	R/W	268
Db78	M	Envelope max current segment Y1	0.0	°C/°F	-999.9...999.9	A	R/W	278
Db79	M	Envelope max current segment X2	0.0	°C/°F	-999.9...999.9	A	R/W	273
Db80	M	Envelope max current segment Y2	0.0	°C/°F	-999.9...999.9	A	R/W	283
Db81	M	Envelope min compression rate segment X1	0.0	°C/°F	-999.9...999.9	A	R/W	267
Db82	M	Envelope min compression rate segment Y1	0.0	°C/°F	-999.9...999.9	A	R/W	277
Db83	M	Envelope min compression rate segment X2	0.0	°C/°F	-999.9...999.9	A	R/W	272
Db84	M	Envelope min compression rate segment Y2	0.0	°C/°F	-999.9...999.9	A	R/W	282
Db85	M	Envelope min delta pressure segment X1	0.0	°C/°F	-999.9...999.9	A	R/W	265
Db86	M	Envelope min delta pressure segment Y1	0.0	°C/°F	-999.9...999.9	A	R/W	275
Db87	M	Envelope min delta pressure segment X2	0.0	°C/°F	-999.9...999.9	A	R/W	270
Db88	M	Envelope min delta pressure segment Y2	0.0	°C/°F	-999.9...999.9	A	R/W	280
Db89	M	Envelope max compression rate segment X1	0.0	°C/°F	-999.9...999.9	A	R/W	266
Db90	M	Envelope max compression rate segment Y1	0.0	°C/°F	-999.9...999.9	A	R/W	276
Db91	M	Envelope max compression rate segment X2	0.0	°C/°F	-999.9...999.9	A	R/W	271
Db92	M	Envelope max compression rate segment Y2	0.0	°C/°F	-999.9...999.9	A	R/W	281
Db93	M	Envelope max capacity segment X1	0.0	°C/°F	-999.9...999.9	A	R/W	264
Db94	M	Envelope max capacity segment Y1	0.0	°C/°F	-999.9...999.9	A	R/W	274
Db95	M	Envelope max capacity segment X2	0.0	°C/°F	-999.9...999.9	A	R/W	269
Db96	M	Envelope max capacity segment Y2	0.0	°C/°F	-999.9...999.9	A	R/W	279
Db97	M	Envelope max capacity limit	75.0	%	0.0...100.0	A	R/W	263
Db98	M	Envelope discharge min temperature	60.0	°C/°F	-999.9...999.9	A	R/W	259
Db99	M	Envelope discharge max temperature	120.0	°C/°F	-999.9...999.9	A	R/W	258
Dc01	M	Compressor inverter alarm contact NO/NC logic	0	---	0: AL.IF OPEN 1: AL.IF CLOSE	D	R/W	496
Dc02	M	Inverter RUN NO/NC contact logic	1	---	0: RUN IF OPEN 1: RUN IF CLOSE	D	R/W	499
Dc03	M	Inverter Start NO/NC contact logic	0	---	0: ON IF CLOSE 1: ON IF OPEN	D	R/W	500
Dc04	M	Inverter Emergency shut-off NO/NC contact logic	1	---	0: ON IF CLOSE 1: ON IF OPEN	D	R/W	498
Dc05	M	Inverter Alarm reset NO/NC contact logic	0	---	0: ON IF CLOSE 1: ON IF OPEN	D	R/W	497
Dc06	M	Inverter minimum frequency	30.0	Hz	0.0...99.9	A	R/W	295
Dc07	M	Inverter maximum frequency	70.0	Hz	0.0...999.0	A	R/W	294
Dc08	M	Inverter compressor StartUp time	30	s	0...999	I	R/W	464
Dc09	M	Inverter compressor ShutOff time	30	s	0...999	I	R/W	465
Dc10	M	Enable Modbus Master (3.0) inverter communication	0	---	0...1	D	R/W	580
Dc11	M	Inverter compressor address comp1 circ1	1	---	1...255	I	R/W	466
Dc12	M	Inverter compressor address comp1 circ2	2	---	1...255	I	R/W	467

7.8 HW-SW

Parameter code	PWD	Description	Default	UOM	Range	Type	R/W	BMS index
E001	S	Unit of measurement for temperature (0: °C; 1: °F)	0	---	0: INTERNATIONAL (°C) 1: IMPERIAL (°F)	D	R/W	92
E002	S	Unit of measurement for pressure (0: barg; 1: psig)	0	---	0: INTERNATIONAL (barg) 1: IMPERIAL (psig)	D	R/W	93
E003	S	Date format	1	---	0: --- 1: DD/MM/YY 2: MM/DD/YY 3: YY.MM.DD	I	R/W	282
E004	S	Protocol type on BMS port	2	---	0: NONE 1: CAREL RS485 2: MODBUS RS485 3: pCO MANAGER	I	R/W	388
E005	S	BMS speed	4	---	0: 1200bps 1: 2400bps 2: 4800bps 3: 9600bps 4: 19200bps	I	R/W	215
E006	S	BMS Address	1	---	0...207	I	R/W	208
E007	S	Protocol type on slave port BMS2	2	---	0: NONE 1: CAREL RS485 2: MODBUS RS485 3: pCO MANAGER	I	R/W	389
E008	S	BMS2 baudrate	4	---	0: 1200bps 1: 2400bps 2: 4800bps 3: 9600bps 4: 19200bps	I	R/W	216
E009	S	BMS2 address	1	---	00: N 1: Y ...207	I	R/W	209
E011	S	Reset hour counters	0	---	0: N	D	R/W	519

Parameter code	PWD	Description	Default	UOM	Range	Type	R/W	BMS index
					1: Y			
E012	M	Enable IO test	0	---	0...1	D	R/W	482
E018	M	IO test board selection	0	---	0: MASTER 1: SLAVE	D	R/W	501
E013	M	Digital output test channel	1	---	0...30	I	R/W	293
E014	M	Digital output test value	0	---	0: OPEN 1: CLOSE	D	R/W	472
E015	M	Analogue output test channel	1	---	0...6	I	R/W	214
E016	M	Analogue output test value	0.0	%	0.0...100.0	A	R/W	214
E017	M	Default installation	0	---	0: NO 1: YES	I	R/W	463
E017	M	Default installation	0	---	0 1: Please wait...	I	R	463

7.9 Log-Out

Parameter code	PWD	Description	Default	UOM	Range	Type	R/W	BMS index
---	U	Password run	0	---	0: --- 1: User 2: Service 3: Manufacturer	I	R	
F001	U	New user password	1234	---	0...9999	I	R/W	
F002	S	New service password	1234	---	0...9999	I	R/W	
F003	M	Manufacturer password	1234	---	0...9999	I	R/W	

8. SUPERVISOR TABLE

FLSTDmSCHE can be connected to various systems of supervision, in particular can be used the following communication protocols BMS: Carel and Modbus.

The connection is done by means of a BMS serial port.

The various connection protocols are managed by the following option cards:

- **Carel RS485:** code PCOS004850
- **Modbus RS485:** code PCOS004850

The Modbus® address is the address specified in the Modbus® frame.

The following tables shows the variables sent to the supervisor.



Note: In the column indexes are shown Carel addresses of consecutive indices, but the Carel protocol only handles up at the 207 analog, 207 and 207 of the entire digital.

8.1 Analog variables

MB Index	Carel index	Par. code	Description	Def.	UOM	Range	R/W	Variable name
1	1	---	Inverter frequency compressor 1 circuit 1	0	---	0...999.9	R	Comp1Circ1InvFreq
2	2	---	Inverter frequency compressor 1 circuit 2	0	---	0...999.9	R	Comp1Circ2InvFreq
3	3	---	Inverter frequency compressor 1 circuit 4	0	---	0...999.9	R	Comp1Circ4InvFreq
4	4	---	Inverter frequency compressor 1 circuit 3	0	---	0...999.9	R	Comp1Circ3InvFreq
5	5	---	Condenser fan setpoint circuit 2	13.0	°C/°F	0...999.9	R	CondFanSetPCirc2_Msk
6	6	---	Condenser fan setpoint circuit 1	13.0	°C/°F	0...999.9	R	CondFanSetPCirc1_Msk
7	7	---	Condenser fan setpoint circuit 4	13.0	°C/°F	0...999.9	R	CondFanSetPCirc4_Msk
8	8	---	Condenser fan setpoint circuit 3	13.0	°C/°F	0...999.9	R	CondFanSetPCirc3_Msk
9	9	---	Condenser fan 1 output request circuit 1	13.0	%	0...999.9	R	CondFanCirc1
10	10	---	Condenser fan output request circuit 2	13.0	%	0...999.9	R	CondFanCirc2
11	11	---	Condenser fan output request circuit 4	13.0	%	0...999.9	R	CondFanCirc4
12	12	---	Condenser fan output request circuit 3	13.0	%	0...999.9	R	CondFanCirc3
13	13	---	Discharge Superheat circuit 2	0	°C/°F	-3276.8...3276.7	R	DscgSH_Circ2_Msk
14	14	---	Discharge Superheat circuit 1	0	°C/°F	-3276.8...3276.7	R	DscgSH_Circ1_Msk
15	15	---	Discharge Superheat circuit 4	0	°C/°F	-3276.8...3276.7	R	DscgSH_Circ4_Msk
16	16	---	Discharge Superheat circuit 3	0	°C/°F	-3276.8...3276.7	R	DscgSH_Circ3_Msk
17	17	---	Superheat circuit 2	0	°C/°F	-3276.8...3276.7	R	SH_Circ2_Msk
18	18	---	Superheat circuit 1	0	°C/°F	-3276.8...3276.7	R	SH_Circ1_Msk
19	19	---	Superheat circuit 4	0	°C/°F	-3276.8...3276.7	R	SH_Circ4_Msk
20	20	---	Superheat circuit 3	0	°C/°F	-3276.8...3276.7	R	SH_Circ3_Msk
21	21	---	Valve opening percent circuit 1	0	---	0...100.0	R	A17_EEV_POSITION_PERC ENT_SHOW
22	22	---	Valve opening percent circuit 2	0	---	0...100.0	R	A17_EEV_POSITION_PERC ENT_SHOW
23	23	---	Valve opening percent circuit 3	0	---	0...100.0	R	EVO3_A17_EEV_POSITION_ PERC_SHOW
24	24	---	Valve opening percent circuit 4	0	---	0...100.0	R	EVO4_A17_EEV_POSITION_ PERC_SHOW
25	25	---	Outlet water temperature	0	°C/°F	-999.9...999.9	R	W_OutTemp_Msk
26	26	---	Inlet water temperature	0	°C/°F	0...99.9	R	W_InTemp_Msk
27	27	---	Actual setpoint	0	°C/°F	0...999.9	R	SetP_Act_Msk
28	28	---	Power request	0	%	0...999.9	R	PwrReq
29	29	---	Inverter request to compressor 1 circuit 1	0	---	0...100.0	R	Comp1Circ1InvReq
30	30	---	Inverter request to compressor 1 circuit 2	0	---	0...100.0	R	Comp1Circ2InvReq
31	31	---	Inverter request to compressor 1 circuit 3	0	---	0...100.0	R	Comp1Circ3InvReq
32	32	---	Inverter request to compressor 1 circuit 4	0	---	0...100.0	R	Comp1Circ4InvReq
33	33	---	Suction pressure circuit 1	0	barg/psig	-999.9...999.9	R	SuctP_Circ1_Msk
34	34	---	Suction pressure circuit 2	0	barg/psig	-999.9...999.9	R	SuctP_Circ2_Msk
35	35	---	Suction pressure circuit 4	0	barg/psig	-999.9...999.9	R	SuctP_Circ4_Msk
36	36	---	Suction pressure circuit 3	0	barg/psig	-999.9...999.9	R	SuctP_Circ3_Msk
37	37	---	Evaporation temperature circuit 1	0	°C/°F	-999.9...999.9	R	EvapTempCirc1_Msk
38	38	---	Evaporation temperature circuit 2	0	°C/°F	-999.9...999.9	R	EvapTempCirc2_Msk
39	39	---	Evaporation temperature circuit 4	0	°C/°F	-999.9...999.9	R	EvapTempCirc4_Msk
40	40	---	Evaporation temperature circuit 3	0	°C/°F	-999.9...999.9	R	EvapTempCirc3_Msk
41	41	---	Suction temperature circuit 1	0	°C/°F	-999.9...999.9	R	SuctTempCirc1_Msk
42	42	---	Suction temperature circuit 2	0	°C/°F	-999.9...999.9	R	SuctTempCirc2_Msk
43	43	---	Suction temperature circuit 4	0	°C/°F	-999.9...999.9	R	SuctTempCirc4_Msk
44	44	---	Suction temperature circuit 3	0	°C/°F	-999.9...999.9	R	SuctTempCirc3_Msk
45	45	---	Discharge pressure circuit 1	0	barg/psig	-999.9...999.9	R	DscgP_Circ1_Msk
46	46	---	Discharge pressure circuit 2	0	barg/psig	-999.9...999.9	R	DscgP_Circ2_Msk
47	47	---	Discharge pressure circuit 4	0	barg/psig	-999.9...999.9	R	DscgP_Circ4_Msk
48	48	---	Discharge pressure circuit 3	0	barg/psig	-999.9...999.9	R	DscgP_Circ3_Msk
49	49	---	Condensing temperature circuit 1	0	°C/°F	-999.9...999.9	R	CondTempCirc1_Msk
50	50	---	Condensing temperature circuit 2	0	°C/°F	-999.9...999.9	R	CondTempCirc2_Msk
51	51	---	Condensing temperature circuit 4	0	°C/°F	-999.9...999.9	R	CondTempCirc4_Msk
52	52	---	Condensing temperature circuit 3	0	°C/°F	-999.9...999.9	R	CondTempCirc3_Msk
53	53	---	Discharge temperature circuit 1	0	°C/°F	-999.9...999.9	R	DscgTempCirc1_Msk
54	54	---	Discharge temperature circuit 2	0	°C/°F	-999.9...999.9	R	DscgTempCirc2_Msk
55	55	---	Discharge temperature circuit 4	0	°C/°F	-999.9...999.9	R	DscgTempCirc4_Msk
56	56	---	Discharge temperature circuit 3	0	°C/°F	-999.9...999.9	R	DscgTempCirc3_Msk
57	57	---	External temperature	0	°C/°F	-999.9...999.9	R	ExtTemp_Msk
58	58	Q002	Cooling setpoint	12.0	°C/°F	-999.9...999.9	R/W	CoolSetP_Msk

MB Index	Carel index	Par. code	Description	Def.	UOM	Range	R/W	Variable name
59	59	Q003	Heating setpoint	40.0	°C/°F	-999.9...999.9	R/W	HeatSetP_Msk
60	60	---	Setpoint from BMS	0	°C/°F	-999.9...999.9	R/W	BMS_SetP
61	61	---	Current compressor 1 circuit 1	0	A	-999.9...999.9	R	CurrComp1Circ1
62	62	---	Current compressor 1 circuit 2	0	A	-999.9...999.9	R	CurrComp1Circ2
63	63	---	Current compressor 1 circuit 4	0	A	-999.9...999.9	R	CurrComp1Circ4
64	64	---	Current compressor 1 circuit 3	0	A	-999.9...999.9	R	CurrComp1Circ3
208	208	A027	Antifreeze alarm differential	2.0	°C/°F	0...999.9	R/W	AFreezeHeatDiff_Msk
209	209	A026	Antifreeze alarm setpoint	4.0	°C/°F	-99.9...99.9	R/W	AFreezeHeatSetp_Msk
210	210	C038	Antifreeze condenser alarm differential	30.0	°C/°F	0...999.9	R/W	AI_FreezeCondDiff_Msk
211	211	C037	Antifreeze condenser alarm threshold	-1.5	°C/°F	-999.9...999.9	R/W	AI_FreezeCondThrsh_Msk
212	212	A029	Antifreeze alarm differential	30.0	°C/°F	0...999.9	R/W	AI_FreezeDiff_Msk
213	213	A028	Antifreeze alarm threshold	-0.8	°C/°F	-999.9...999.9	R/W	AI_FreezeThrsh_Msk
214	214	E016	Analogue output test value	0	%	0...100.0	R/W	AOut_TestVal
215	215	C028	Compressor power on defrost entering	50.0	%	0...100.0	R/W	CompPwrInDfrRev
216	216	C029	Compressor power on defrost exiting	0	%	0...100.0	R/W	CompPwrOutDfrRev
217	217	---	Condenser fan command for inverter circuit 1 & 2 (common air circuit)	0	%	0...999.9	R	CondFanCirc1_2_Inv
218	218	---	Condenser fan command for inverter circuit 1	0	%	0...999.9	R	CondFanCirc1_Inv
219	219	---	Condenser fan command for inverter circuit 2	0	%	0...999.9	R	CondFanCirc2_Inv
220	220	C018	Condenser fan differential in chiller mode	15.0	°C/°F	0...999.9	R/W	CondFanDiffCH_Msk
221	221	C021	Condenser fan differential in heatpump mode	5.0	°C/°F	0...999.9	R/W	CondFanDiffHP_Msk
222	222	C023	Condenser fan maximum speed	8.0	V	4.0...10.0	R/W	CondFanMaxSpeed
223	223	C022	Condenser fan minimum speed	2.0	V	0...10.0	R/W	CondFanMinSpeed
224	224	---	Condenser fan pressure probe value circuit 1	2.0	barg/psig	0...999.9	R	CondFanP_PrbCirc1_Msk
225	225	---	Condenser fan pressure probe value circuit 2	2.0	barg/psig	0...999.9	R	CondFanP_PrbCirc2_Msk
226	226	---	Condenser fan pressure probe value circuit 3	2.0	barg/psig	0...999.9	R	CondFanP_PrbCirc3_Msk
227	227	---	Condenser fan pressure probe value circuit 4	2.0	barg/psig	0...999.9	R	CondFanP_PrbCirc4_Msk
228	228	---	Condenser fan temperature probe value circuit 1	13.0	°C/°F	0...999.9	R	CondFanPrbCirc1_Msk
229	229	---	Condenser fan temperature probe value circuit 2	13.0	°C/°F	0...999.9	R	CondFanPrbCirc2_Msk
230	230	---	Condenser fan temperature probe value circuit 3	13.0	°C/°F	0...999.9	R	CondFanPrbCirc3_Msk
231	231	---	Condenser fan temperature probe value circuit 4	13.0	°C/°F	0...999.9	R	CondFanPrbCirc4_Msk
232	232	C014	Condenser fan setpoint in chiller mode	23.0	°C/°F	-999.9...999.9	R/W	CondFanSetP_CH_Msk
233	233	C019	Condenser fan setpoint in heatpump mode	12.0	°C/°F	-999.9...999.9	R/W	CondFanSetP_HP_Msk
234	234	C016	Condenser fan setpoint at startup in chiller mode	45.0	°C/°F	-999.9...999.9	R/W	CondFanStartupSetP_CH_Msk
235	235	Da13	Condensing maximum temperature envelop limit	65.0	°C/°F	-999.9...999.9	R/W	CondMaxTemp_Msk
236	236	C015	Condenser setpoint offset	5.0	°C/°F	0...999.9	R/W	CondSetP_Ofs_Msk
237	237	Da53	Offset current probe compressor 1	0	A	-99.9...99.9	R/W	CurrentPrbCirc1_Ofs
238	238	Da54	Offset current probe compressor 1	0	A	-99.9...99.9	R/W	CurrentPrbCirc2_Ofs
239	239	Da89	Offset current probe compressor 3	0	A	-99.9...99.9	R/W	CurrentPrbCirc3_Ofs
240	240	Da90	Offset current probe compressor 4	0	A	-99.9...99.9	R/W	CurrentPrbCirc4_Ofs
241	241	Da52	Max value current probe	50.0	A	0...999.9	R/W	CurrentPrbMaxVal
242	242	Da51	Min value current probe	0	A	0...999.9	R/W	CurrentPrbMinVal
243	243	A046	Delta temp Free Cooling design (to reach unit nominal capacity)	10.0	°C/°F	0...999.9	R/W	DeltaTempFC_design_Msk
244	244	A045	Delta temp FC to activate free-cooling coil regulation	3.0	°C/°F	0...99.9	R/W	DeltaTempFC_RegOn_Msk
245	245	Da2A	Value of delta pressure for a correct change of the reverse valve	3.0	barg/psig	0...999.9	R/W	DP_ThrshRevVlv_Msk
246	246	Da67	Max value discharge pressure probe	30.0	barg/psig	0...99.9	R/W	DscgP_PrbMaxVal_Msk
247	247	Da66	Min value discharge pressure probe	0	barg/psig	-99.9...99.9	R/W	DscgP_PrbMinVal_Msk
248	248	Da70	Discharge temperature probe max. value	0	°C/°F	-999.9...999.9	R/W	DscgTempThrshHi_Msk
249	249	Da69	Discharge temperature probe min. value	0	°C/°F	-999.9...999.9	R/W	DscgTempThrshLow_Msk
250	250	---	Direct expansion regulation ramp	0	---	0...100.0	R	DxRegRamp
251	251	Da36	Eco minimum compressor power	75.0	%	0...100.0	R/W	EcoPwrMin
252	252	Da35	Eco temperature differential	3.0	°C/°F	0...999.9	R/W	EcoTempDiff_Msk
253	253	Da34	Eco temperature setpoint	45.0	°C/°F	-999.9...999.9	R/W	EcoTempSetp_Msk
254	254	C026	Defrost end threshold	52.0	°C/°F	-99.9...999.9	R/W	EndDfrThrsh_Msk
255	255	Db72	Envelope condensing max temperature	0	°C/°F	-999.9...999.9	R/W	EnvCondMaxTemp_Msk
256	256	Db75	Envelope max condensing temperature in Eco mode	0	°C/°F	-999.9...999.9	R/W	EnvCondMaxTempEco_Msk
257	257	Db71	Envelope condensing min temperature	0	°C/°F	-999.9...999.9	R/W	EnvCondMinTemp_Msk
258	258	Db99	Envelope discharge max temperature	120.0	°C/°F	-999.9...999.9	R/W	EnvDscgMax_Msk
259	259	Db98	Envelope discharge min temperature	60.0	°C/°F	-999.9...999.9	R/W	EnvDscgMin_Msk
260	260	Db74	Envelope evaporating max temperature	0	°C/°F	-999.9...999.9	R/W	EnvEvapMaxTemp_Msk
261	261	Db76	Envelope max evaporating temperature in Eco mode	0	°C/°F	-999.9...999.9	R/W	EnvEvapMaxTempEco_Msk
262	262	Db73	Envelope evaporating min temperature	0	°C/°F	-999.9...999.9	R/W	EnvEvapMinTemp_Msk
263	263	Db97	Envelope max capacity limit	75.0	%	0...100.0	R/W	EnvMaxCapLim
264	264	Db93	Envelope max capacity segment X1	0	°C/°F	-999.9...999.9	R/W	EnvX1CapMax_Msk
265	265	Db85	Envelope min delta pressure segment X1	0	°C/°F	-999.9...999.9	R/W	EnvX1CompDeltaMin_Msk
266	266	Db89	Envelope max compression rate segment X1	0	°C/°F	-999.9...999.9	R/W	EnvX1CompRateMax_Msk
267	267	Db81	Envelope min compression rate segment X1	0	°C/°F	-999.9...999.9	R/W	EnvX1CompRateMin_Msk
268	268	Db77	Envelope max current segment X1	0	°C/°F	-999.9...999.9	R/W	EnvX1Curr_Msk
269	269	Db95	Envelope max capacity segment X2	0	°C/°F	-999.9...999.9	R/W	EnvX2CapMax_Msk
270	270	Db87	Envelope min delta pressure segment X2	0	°C/°F	-999.9...999.9	R/W	EnvX2CompDeltaMin_Msk
271	271	Db91	Envelope max compression rate segment X2	0	°C/°F	-999.9...999.9	R/W	EnvX2CompRateMax_Msk
272	272	Db83	Envelope min compression rate segment X2	0	°C/°F	-999.9...999.9	R/W	EnvX2CompRateMin_Msk
273	273	Db79	Envelope max current segment X2	0	°C/°F	-999.9...999.9	R/W	EnvX2Curr_Msk
274	274	Db94	Envelope max capacity segment Y1	0	°C/°F	-999.9...999.9	R/W	EnvY1CapMax_Msk
275	275	Db86	Envelope min delta pressure segment Y1	0	°C/°F	-999.9...999.9	R/W	EnvY1CompDeltaMin_Msk
276	276	Db90	Envelope max compression rate segment Y1	0	°C/°F	-999.9...999.9	R/W	EnvY1CompRateMax_Msk
277	277	Db82	Envelope min compression rate segment Y1	0	°C/°F	-999.9...999.9	R/W	EnvY1CompRateMin_Msk
278	278	Db78	Envelope max current segment Y1	0	°C/°F	-999.9...999.9	R/W	EnvY1Curr_Msk
279	279	Db96	Envelope max capacity segment Y2	0	°C/°F	-999.9...999.9	R/W	EnvY2CapMax_Msk
280	280	Db88	Envelope min delta pressure segment Y2	0	°C/°F	-999.9...999.9	R/W	EnvY2CompDeltaMin_Msk

MB Index	Carel index	Par. code	Description	Def.	UOM	Range	R/W	Variable name
281	281	Db92	Envelope max compression rate segment Y2	0	°C/°F	-999.9...999.9	R/W	EnvY2CompRateMax_Msk
282	282	Db84	Envelope min compression rate segment Y2	0	°C/°F	-999.9...999.9	R/W	EnvY2CompRateMin_Msk
283	283	Db80	Envelope max current segment Y2	0	°C/°F	-999.9...999.9	R/W	EnvY2Curr_Msk
284	284	Da12	Evaporating minimum temperature envelop limit	-20.0	°C/°F	-999.9...999.9	R/W	EvapMinTemp_Msk
285	285	C020	Evaporator setpoint offset	3.0	°C/°F	0...999.9	R/W	EvapSetP_Ofs_Msk
286	286	C073	Fan differential Chiller mode	50	%	0...100	R/W	FanDiffCH
287	287	C074	Fan differential Heat Pump mode	60	%	0...100	R/W	FanDiffHP
288	288	---	Free Cooling damper regulation ramp	0	---	0...100.0	R	FC_DamperRegRamp
289	289	---	Free Cooling coil regulation factor	15.0	%	10.0...100.0	R	FC_FixedGainFactor
290	290	---	Free Cooling coil regulation factor	15.0	%	10.0...100.0	R	FC_GainFactor
291	291	---	Free Cooling coil regulation factor	15.0	%	10.0...100.0	R	FC_MaxGainFactor
292	292	Da1A	Compressor maximum operating current (SETPOINT)	0	amp	0...3276.7	R/W	FLA_Comp
293	293	B028	EEV: High condensing temperature threshold	0	°C/°F	0...999.9	R/W	HiCondTempThrsH
294	294	Dc07	Inverter maximum frequency	70.0	Hz	0...999.0	R/W	InvHighFreq
295	295	Dc06	Inverter minimum frequency	30.0	Hz	0...999.9	R/W	InvLowFreq
296	296	Da38	Liquid injection differential	10.0	°C/°F	0...999.9	R/W	LiqdInjDiff_Msk
297	297	Da37	Liquid injection temperature setpoint	100.0	°C/°F	-999.9...999.9	R/W	LiqdInjSetp_Msk
298	298	B017	EEV Low evaporating temp. threshold in Chiller mode	-50.0	°C/°F	-99.9...99.9	R/W	LOP_ThrschCH_Msk
299	299	B019	EEV Low evaporating temp. threshold in HeatPump mode	-50.0	°C/°F	-99.9...99.9	R/W	LOP_ThrschHP_Msk
300	300	B018	Integral time LOP regulation in chiller mode	15.0	s	0...800.0	R/W	LOP_TiCH
301	301	B020	Integral time LOP regulation in heating mode	15.0	s	0...800.0	R/W	LOP_TiHP
302	302	B013	EEV Low SuperHeating threshold in Chiller mode	2.0	°C/°F	0...99.9	R/W	LowSH_ThrschCH_Msk
303	303	B015	EEV Low SuperHeating threshold in HeatPump mode	2.0	°C/°F	0...99.9	R/W	LowSH_ThrschHP_Msk
304	304	B014	Integral time Low SH in chiller mode	15.0	s	0...800.0	R/W	LowSH_TiCH
305	305	B016	Integral time Low SH in heating mode	15.0	s	0...800.0	R/W	LowSH_TiHP
306	306	B031	EEV: Low suction temperature threshold	0	°C/°F	-999.9...999.9	R/W	LowSuctTempThrsH
307	307	Db65	Min power of steplless compressor	25.0	%	0...100.0	R/W	MinPwr
308	308	B021	EEV High evaporating temp. threshold in Chiller mode	20.0	°C/°F	0...999.9	R/W	MOP_ThrschCH_Msk
309	309	B023	EEV High evaporating temp. threshold in HeatPump mode	20.0	°C/°F	0...999.9	R/W	MOP_ThrschHP_Msk
310	310	B022	Integral time MOP regulation in chiller mode	20.0	s	0...800.0	R/W	MOP_TiCH
311	311	B024	Integral time MOP regulation in heating mode	20.0	s	0...800.0	R/W	MOP_TiHP
312	312	B006	Proportional gain SH regulation in chiller mode	15.0	---	1.0...800.0	R/W	PID_KpCH
313	313	B010	Proportional gain SH regulation in heating mode	15.0	---	1.0...800.0	R/W	PID_KpHP
314	314	B008	Derivative time SH regulation in chiller mode	5.0	s	0...800.0	R/W	PID_TdCH
315	315	B012	Derivative time SH regulation in heating mode	5.0	s	0...800.0	R/W	PID_TdHP
316	316	B035	Pumpdown end evaporation temperature threshold	-11.0	°C/°F	-999.9...999.9	R/W	PmpDwnEndTempThrsH_Msk
317	317	A031	Offset probe U1	0	°C/°F	-99.9...99.9	R/W	Prb1_Ofs_Msk
318	318	A032	Offset probe U2	0	°C/°F	-99.9...99.9	R/W	Prb2_Ofs_Msk
319	319	C040	Offset probe U3	0	°C/°F	-99.9...99.9	R/W	Prb3_Ofs_Msk
320	320	Db54	Compressor power step 1	25.0	%	0...100.0	R/W	PwrStep1
321	321	Db55	Compressor power step 2	50.0	%	0...100.0	R/W	PwrStep2
322	322	Db56	Compressor power step 3	75.0	%	0...100.0	R/W	PwrStep3
323	323	---	Regulation Ramp (e.g. from Temperature controller)	0	---	0...100.0	R	RegRamp
324	324	---	Temperature request by run PID	0	%	0...100.0	R	ReqPID_Run
325	325	---	Temperature request by startup PID	0	---	0...100.0	R	ReqPID_Startup
326	326	A018	Run regulation proportional band	10.0	°C/°F	-999.9...999.9	R/W	RunTempRegPB_Msk
327	327	Da61	Suction pressure circuit 1 offset	0	barg/psig	-999.9...999.9	R/W	S1_Circ1_PrbsOfs
328	328	Da63	Suction pressure circuit 2 offset	0	barg/psig	-999.9...999.9	R/W	S1_Circ2_PrbsOfs
329	329	Da91	Suction pressure circuit 3 offset	0	barg/psig	-999.9...999.9	R/W	S1_Circ3_PrbsOfs
330	330	Da93	Suction pressure circuit 4 offset	0	barg/psig	-999.9...999.9	R/W	S1_Circ4_PrbsOfs
331	331	Da62	Suction temperature circuit 1 offset	0	°C/°F	-999.9...999.9	R/W	S2_Circ1_PrbsOfs
332	332	Da64	Suction temperature circuit 2 offset	0	°C/°F	-999.9...999.9	R/W	S2_Circ2_PrbsOfs
333	333	Da92	Suction temperature circuit 3 offset	0	°C/°F	-999.9...999.9	R/W	S2_Circ3_PrbsOfs
334	334	Da94	Suction temperature circuit 4 offset	0	°C/°F	-999.9...999.9	R/W	S2_Circ4_PrbsOfs
335	335	Da71	Discharge pressure circuit 1 offset	0	barg/psig	-999.9...999.9	R/W	S3_Circ1_PrbsOfs
336	336	Da73	Discharge pressure circuit 2 offset	0	barg/psig	-999.9...999.9	R/W	S3_Circ2_PrbsOfs
337	337	Da95	Discharge pressure circuit 3 offset	0	barg/psig	-999.9...999.9	R/W	S3_Circ3_PrbsOfs
338	338	Da97	Discharge pressure circuit 4 offset	0	barg/psig	-999.9...999.9	R/W	S3_Circ4_PrbsOfs
339	339	Da72	Discharge temperature circuit 1 offset	0	°C/°F	-999.9...999.9	R/W	S4_Circ1_PrbsOfs
340	340	Da74	Discharge temperature circuit 2 offset	0	°C/°F	-999.9...999.9	R/W	S4_Circ2_PrbsOfs
341	341	Da96	Discharge temperature circuit 3 offset	0	°C/°F	-999.9...999.9	R/W	S4_Circ3_PrbsOfs
342	342	Da98	Discharge temperature circuit 4 offset	0	°C/°F	-999.9...999.9	R/W	S4_Circ4_PrbsOfs
343	343	B005	SuperHeat setpoint in Chiller mode	8.0	°C/°F	5.0...99.9	R/W	SH_SetCH_Msk
344	344	B009	SuperHeat setpoint in HeatPump mode	8.0	°C/°F	5.0...99.9	R/W	SH_SetHP_Msk
345	345	C024	Defrost start threshold	-1.0	°C/°F	-99.9...999.9	R/W	StartDirThrsH_Msk
346	346	C025	Defrost start threshold reset	1.0	°C/°F	-99.9...999.9	R/W	StartDirThrsRes_Msk
347	347	Db52	Start/stop power	25.0	%	0...100.0	R/W	StartStopPwr
348	348	A015	Startup regulation proportional band	16.0	°C/°F	-999.9...999.9	R/W	StartupTempRegPB_Msk
349	349	Da57	Max value suction pressure probe	30.0	barg/psig	0...99.9	R/W	SuctP_PrbsMaxValMsk
350	350	Da56	Min value suction pressure probe	0	barg/psig	-99.9...99.9	R/W	SuctP_PrbsMinVal_Msk
351	351	Da60	Suction temperature threshold probe high	0	°C/°F	-999.9...999.9	R/W	SuctTempThrsHi_Msk
352	352	Da59	Suction temperature threshold probe low	0	°C/°F	-999.9...999.9	R/W	SuctTempThrsLow_Msk
353	353	A006	Temperature high setpoint limits in chiller	20.0	°C/°F	-3276.8...3276.7	R/W	TempHiSetP_CH_Msk
354	354	A008	Temperature high setpoint limits in heat pump	45.0	°C/°F	-3276.8...3276.7	R/W	TempHiSetP_HP_Msk
355	355	A005	Temperature low setpoint limits in chiller	5.0	°C/°F	-3276.8...3276.7	R/W	TempLowSetP_CH_Msk
356	356	A007	Temperature low setpoint limits in heat pump	30.0	°C/°F	-3276.8...3276.7	R/W	TempLowSetP_HP_Msk
357	357	Db03	Pulsing valve: decrement pulse time	1.0	s	0.1...9.9	R/W	VlvPlsT_Decr
358	358	Db02	Pulsing valve: increment pulse time	1.0	s	0.1...9.9	R/W	VlvPlsT_Incr
359	359	---	Reference water temperature to run PID	0	°C/°F	-3276.8...3276.7	R	W_RegRunPID_Msk
360	360	---	Reference water temperature to startup PID	0	°C/°F	-3276.8...3276.7	R	W_RegStartupPID_Msk

MB Index	Carel index	Par. code	Description	Def.	UOM	Range	R/W	Variable name
361	361	A048	High water temperature alarm offset over setpoint	6.0	°C/°F	0...99.9	R/W	HighWaterTempOfs_Msk
363	363	B029	High condensing temperature: integral time	-777.7	---	0...800.0	R/W	A57_HITCOND_Ti_msk

8.2 Integer variables

MB Index	Carel index	Par. code	Description	Def.	UOM	Range	R/W	Variable name
5002	1	---	Compressor 1 running power circuit 1	0	%	0...999	R	Comp1Circ1PwrRunInt
5003	2	---	Compressor 1 running power circuit 2	0	%	0...999	R	Comp1Circ2PwrRunInt
5004	3	---	Compressor 1 running power circuit 4	0	%	0...999	R	Comp1Circ4PwrRunInt
5005	4	---	Compressor 1 running power circuit 3	0	%	0...999	R	Comp1Circ3PwrRunInt
5006	5	---	Compressor 1 circuit 2 power status	0	---	0...9	R	Comp1Circ2_PwrStatus
5007	6	---	Compressor 1 circuit 1 power status	0	---	0...9	R	Comp1Circ1_PwrStatus
5008	7	---	Compressor 1 circuit 3 power status	0	---	0...9	R	Comp1Circ3_PwrStatus
5009	8	---	Compressor 1 circuit 4 power status	0	---	0...9	R	Comp1Circ4_PwrStatus
5010	9	---	Envelope working point circuit 1	0	---	0...9	R	EnvZoneCirc1
5011	10	---	Envelope working point circuit 2	0	---	0...9	R	EnvZoneCirc2
5012	11	---	Envelope working point circuit 3	0	---	0...9	R	EnvZoneCirc3
5013	12	---	Envelope working point circuit 4	0	---	0...9	R	EnvZoneCirc4
5014	13	---	Compressor 1 device available status circuit 1	0	---	0...99	R	Comp1Circ1DevAvbl
5015	14	---	Compressor 1 device available status circuit 2	0	---	0...99	R	Comp1Circ2DevAvbl
5016	15	---	Compressor 1 device available status circuit 3	0	---	0...99	R	Comp1Circ3DevAvbl
5017	16	---	Compressor 1 device available status circuit 4	0	---	0...99	R	Comp1Circ4DevAvbl
5018	17	---	EEV position circuit 1	0	---	0...9999	R	I4_EEV_POSITION_STEPS_msk
5019	18	---	EEV position circuito 2	0	---	0...9999	R	I4_EEV_POSITION_STEPS_msk
5020	19	---	EEV position circuit 3	0	---	0...9999	R	EVO3_I4_EEV_POSITION_STEPS_msk
5021	20	---	EEV position circuit 4	0	---	0...9999	R	EVO4_I4_EEV_POSITION_STEPS_msk
5022	21	Da02	Compressor 1 manual control circuit 1	0	%	0...101	R/W	Comp1Circ1Man
5023	22	Da04	Compressor 1 manual control circuit 2	0	%	0...101	R/W	Comp1Circ2Man
5024	23	Da88	Compressor 1 manual control circuit 4	0	%	0...101	R/W	Comp1Circ4Man
5025	24	Da86	Compressor 1 manual control circuit 3	0	%	0...101	R/W	Comp1Circ3Man
5026	25	---	Compressor 1 circuit 1 working hours	0	x1000h	0...999	R	Comp1Circ1HiHrs
5027	26	---	Compressor 1 circuit 2 working hours	0	x1000h	0...999	R	Comp1Circ2HiHrs
5028	27	---	Compressor 1 circuit 4 working hours	0	x1000h	0...999	R	Comp1Circ4HiHrs
5029	28	---	Compressor 1 circuit 3 working hours	0	x1000h	0...999	R	Comp1Circ3HiHrs
5030	29	---	Compressor 1 circuit 1 working hours	0	h	0...999	R	Comp1Circ1LowHrs
5031	30	---	Compressor 1 circuit 2 working hours	0	h	0...999	R	Comp1Circ2LowHrs
5032	31	---	Compressor 1 circuit 4 working hours	0	h	0...999	R	Comp1Circ4LowHrs
5033	32	---	Compressor 1 circuit 3 working hours	0	h	0...999	R	Comp1Circ3LowHrs
5034	33	Da01	Compressor 1 hour threshold	30	x1000h	0...999	R/W	Comp1Circ1HrsThrs
5035	34	Da03	Compressor 2 hour threshold	30	x1000h	0...999	R/W	Comp1Circ2HrsThrs
5036	35	Da87	Compressor 4 hour threshold	30	x1000h	0...999	R/W	Comp1Circ4HrsThrs
5037	36	Da85	Compressor 3 hour threshold	30	x1000h	0...999	R/W	Comp1Circ3HrsThrs
5038	37	---	Compressor 1 valve 1 command circuit 1	0	---	0...9	R	Comp1Circ1V1v1Cmd
5039	38	---	Compressor 1 valve 1 command circuit 2	0	---	-32768...32767	R	Comp1Circ2V1v1Cmd
5040	39	---	Compressor 1 valve 1 command circuit 4	0	---	0...9	R	Comp1Circ4V1v1Cmd
5041	40	---	Compressor 1 valve 1 command circuit 3	0	---	0...9	R	Comp1Circ3V1v1Cmd
5042	41	---	Compressor 1 valve 2 command circuit 1	0	---	0...9	R	Comp1Circ1V2v2Cmd
5043	42	---	Compressor 1 valve 2 command circuit 2	0	---	-32768...32767	R	Comp1Circ2V2v2Cmd
5044	43	---	Compressor 1 valve 2 command circuit 4	0	---	0...9	R	Comp1Circ4V2v2Cmd
5045	44	---	Compressor 1 valve 2 command circuit 3	0	---	0...9	R	Comp1Circ3V2v2Cmd
5046	45	---	Compressor 1 valve 3 command circuit 1	0	---	0...9	R	Comp1Circ1V3v3Cmd
5047	46	---	Compressor 1 valve 3 command circuit 2	0	---	-32768...32767	R	Comp1Circ2V3v3Cmd
5048	47	---	Compressor 1 valve 3 command circuit 4	0	---	0...9	R	Comp1Circ4V3v3Cmd
5049	48	---	Compressor 1 valve 3 command circuit 3	0	---	0...9	R	Comp1Circ3V3v3Cmd
5050	49	---	Compressor 1 valve 4 command circuit 1	0	---	0...9	R	Comp1Circ1V4v4Cmd
5051	50	---	Compressor 1 valve 4 command circuit 2	0	---	-32768...32767	R	Comp1Circ2V4v4Cmd
5052	51	---	Compressor 1 valve 4 command circuit 4	0	---	0...9	R	Comp1Circ4V4v4Cmd
5053	52	---	Compressor 1 valve 4 command circuit 3	0	---	0...9	R	Comp1Circ3V4v4Cmd
5054	53	C006	Condenser Fan manual command circuit 1	0	%	0...101	R/W	CondFanCirc1Man
5055	54	C008	Condenser Fan manual command circuit 2	0	%	0...101	R/W	CondFanCirc2Man
5056	55	C052	Condenser Fan manual command circuit 4	0	%	0...101	R/W	CondFanCirc4Man
5057	56	C050	Condenser Fan manual command circuit 3	0	%	0...101	R/W	CondFanCirc3Man
5058	57	---	Condenser fan 1 circuit 1 working hours	0	x1000h	0...32767	R	CondFan1Circ1HiHrs
5059	58	---	Condenser fan1 circuit 2 working hours	0	x1000h	0...32767	R	CondFan1Circ2HiHrs
5060	59	---	Condenser fan 1 circuit 4 working hours	0	x1000h	0...32767	R	CondFan1Circ4HiHrs
5061	60	---	Condenser fan 1 circuit 3 working hours	0	x1000h	0...32767	R	CondFan1Circ3HiHrs
5062	61	---	Condenser fan 1 circuit 2 working hours	0	h	0...32767	R	CondFan1Circ2LowHrs
5063	62	---	Condenser fan 1 circuit 1 working hours	0	h	0...32767	R	CondFan1Circ1LowHrs
5064	63	---	Condenser fan 1 circuit 4 working hours	0	h	0...32767	R	CondFan1Circ4LowHrs
5065	64	---	Condenser fan 1 circuit 3 working hours	0	h	0...32767	R	CondFan1Circ3LowHrs
5066	65	C005	Circuit 1 condenser fan 1 maintenance hour threshold	99	x1000h	0...999	R/W	CondFan1Circ1HrsThrs
5067	66	C007	Circuit 2 condenser fan 1 maintenance hour threshold	99	x1000h	0...999	R/W	CondFan1Circ2HrsThrs
5068	67	C051	Circuit 4 condenser fan 1 maintenance hour threshold	99	x1000h	0...999	R/W	CondFan1Circ4HrsThrs
5069	68	C049	Circuit 3 condenser fan1 maintenance hour threshold	99	x1000h	0...999	R/W	CondFan1Circ3HrsThrs
5070	69	C053	Condenser Fan 1 manual command circuit 1	0	---	0...2	R/W	CondFan1Circ1Man
5071	70	C058	Condenser Fan 1 manual command circuit 2	0	---	0...2	R/W	CondFan1Circ2Man

MB Index	Carel index	Par. code	Description	Def.	UOM	Range	R/W	Variable name
5072	71	C063	Condenser Fan 1 manual command circuit 3	0	---	0...2	R/W	CondFan1Circ3Man
5073	72	C068	Condenser Fan 1 manual command circuit 4	0	---	0...2	R/W	CondFan1Circ4Man
5074	73	C055	Condenser Fan 2 manual command circuit 1	0	---	0...2	R/W	CondFan2Circ1Man
5075	74	C060	Condenser Fan 2 manual command circuit 2	0	---	0...2	R/W	CondFan2Circ2Man
5076	75	C065	Condenser Fan 2 manual command circuit 3	0	---	0...2	R/W	CondFan2Circ3Man
5077	76	C070	Condenser Fan 2 manual command circuit 4	0	---	0...2	R/W	CondFan2Circ4Man
5078	77	---	Condenser fan 2 circuit 1 working hours	0	x1000h	0...32767	R	CondFan2Circ1HiHrs
5079	78	---	Condenser fan 2 circuit 2 working hours	0	x1000h	0...32767	R	CondFan2Circ2HiHrs
5080	79	---	Condenser fan 2 circuit 3 working hours	0	x1000h	0...32767	R	CondFan2Circ3HiHrs
5081	80	---	Condenser fan 2 circuit 4 working hours	0	x1000h	0...32767	R	CondFan2Circ4HiHrs
5082	81	---	Condenser fan 2 circuit 1 working hours	0	h	0...32767	R	CondFan2Circ1LowHrs
5083	82	---	Condenser fan 2 circuit 2 working hours	0	h	0...32767	R	CondFan2Circ2LowHrs
5084	83	---	Condenser fan 2 circuit 3 working hours	0	h	0...32767	R	CondFan2Circ3LowHrs
5085	84	---	Condenser fan 2 circuit 4 working hours	0	h	0...32767	R	CondFan2Circ4LowHrs
5086	85	C054	Circuit 1 condenser fan 2 maintenance hour threshold	99	x1000h	0...999	R/W	CondFan2Circ1HrsThrsh
5087	86	C059	Circuit 2 condenser fan 2 maintenance hour threshold	99	x1000h	0...999	R/W	CondFan2Circ2HrsThrsh
5088	87	C064	Circuit 3 condenser fan 2 maintenance hour threshold	99	x1000h	0...999	R/W	CondFan2Circ3HrsThrsh
5089	88	C069	Circuit 4 condenser fan 2 maintenance hour threshold	99	x1000h	0...999	R/W	CondFan2Circ4HrsThrsh
5090	89	C057	Condenser Fan 3 manual command circuit 1	0	---	0...2	R/W	CondFan3Circ1Man
5091	90	C062	Condenser Fan 3 manual command circuit 2	0	---	0...2	R/W	CondFan3Circ2Man
5092	91	C067	Condenser Fan 3 manual command circuit 3	0	---	0...2	R/W	CondFan3Circ3Man
5093	92	C072	Condenser Fan 3 manual command circuit 4	0	---	0...2	R/W	CondFan3Circ4Man
5094	93	---	Condenser fan 3 circuit 1 working hours	0	x1000h	0...32767	R	CondFan3Circ1HiHrs
5095	94	---	Condenser fan 3 circuit 2 working hours	0	x1000h	0...32767	R	CondFan3Circ2HiHrs
5096	95	---	Condenser fan 3 circuit 3 working hours	0	x1000h	0...32767	R	CondFan3Circ3HiHrs
5097	96	---	Condenser fan 3 circuit 4 working hours	0	x1000h	0...32767	R	CondFan3Circ4HiHrs
5098	97	---	Condenser fan 3 circuit 1 working----- hours	0	h	0...32767	R	CondFan3Circ1LowHrs
5099	98	---	Condenser fan 3 circuit 2 working hours	0	h	0...32767	R	CondFan3Circ2LowHrs
5100	99	---	Condenser fan 3 circuit 3 working hours	0	h	0...32767	R	CondFan3Circ3LowHrs
5101	100	---	Condenser fan 3 circuit 4 working hours	0	h	0...32767	R	CondFan3Circ4LowHrs
5102	101	C056	Circuit 1 condenser fan 3 maintenance hour threshold	99	x1000h	0...999	R/W	CondFan3Circ1HrsThrsh
5103	102	C061	Circuit 2 condenser fan 3 maintenance hour threshold	99	x1000h	0...999	R/W	CondFan3Circ2HrsThrsh
5104	103	C066	Circuit 3 condenser fan 3 maintenance hour threshold	99	x1000h	0...999	R/W	CondFan3Circ3HrsThrsh
5105	104	C071	Circuit 4 condenser fan 3 maintenance hour threshold	99	x1000h	0...999	R/W	CondFan3Circ4HrsThrsh
5106	105	A002	Evaporator pump in manual mode	0	---	0...2	R/W	EvapPmpMan
5107	106	---	Evaporator pump 1 working hours	0	x1000h	0...32767	R	EvapPmp1HiHrs
5108	107	---	Evaporator pump 1 working hours	0	h	0...32767	R	EvapPmp1LowHrs
5109	108	A001	Evaporator pump 1 maintenance hour threshold	99	x1000h	0...999	R/W	EvapPmp1HrsThrsh
5110	109	---	Evaporator pump 2 working hours	0	x1000h	0...32767	R	EvapPmp2HiHrs
5111	110	---	Evaporator pump 2 working hours	0	h	0...32767	R	EvapPmp2LowHrs
5112	111	A003	Evaporator pump 2 maintenance hour threshold	99	x1000h	0...999	R/W	EvapPmp2HrsThrsh
5113	112	C002	Condenser pump in manual mode	0	---	0...2	R/W	CondPmpMan
5114	113	---	Condenser pump 1 working hours	0	x1000h	0...32767	R	CondPmp1HiHrs
5115	114	---	Condenser pump 1 working hours	0	h	0...32767	R	CondPmp1LowHrs
5116	115	C001	Condenser pump 1 maintenance hour threshold	99	x1000h	0...999	R/W	CondPmp1HrsThrsh
5117	116	---	Condenser pump 2 working hours	0	x1000h	0...32767	R	CondPmp2HiHrs
5118	117	---	Condenser pump 2 working hours	0	h	0...32767	R	CondPmp2LowHrs
5119	118	C003	Condenser pump 2 maintenance hour threshold	99	x1000h	0...999	R/W	CondPmp2HrsThrsh
5120	119	---	BMS software version (include the SwVerX and SwVerY)	15018	---	0...32767	R	BMS_SW_Ver_XY
5121	120	---	BMS software version (include the SwVerZ)	15018	---	0...32767	R	BMS_SW_Ver_Z
5122	121	---	BMS software date	15018	---	0...32767	R	BMS_SW_Date
5123	122	Q008	Clock hour for BMS	0	---	0...23	R/W	BMSHour
5124	123	Q009	Clock minute for BMS	0	---	0...59	R/W	BMSMinute
5125	124	Q005	Day for BMS	0	---	1...31	R/W	BMSDay
5126	125	Q006	Month for BMS	0	---	1...12	R/W	BMSMonth
5127	126	Q007	Year for BMS	0	---	0...99	R/W	BMSYear
5128	127	---	Actual phase run of compressor 1 circuit 1	0	---	0...30	R	ServiceTool_Comp1Circ1PhaseRun
5129	128	---	Actual phase run of compressor 1 circuit 2	0	---	0...30	R	ServiceTool_Comp1Circ2PhaseRun
5130	129	---	Actual phase run of compressor 1 circuit 3	0	---	0...30	R	ServiceTool_Comp1Circ3PhaseRun
5131	130	---	Actual phase run of compressor 1 circuit 4	0	---	0...30	R	ServiceTool_Comp1Circ4PhaseRun
5132	131	---	Temperature value converted	0	°C/°F	-999...999	R	Temp_X0_Circ1
5133	132	---	Temperature value converted	0	°C/°F	-999...999	R	Temp_X1_Circ1
5134	133	---	Temperature value converted	0	°C/°F	-999...999	R	Temp_X2_Circ1
5135	134	---	Temperature value converted	0	°C/°F	-999...999	R	Temp_X3_Circ1
5136	135	---	Temperature value converted	0	°C/°F	-999...999	R	Temp_X4_Circ1
5137	136	---	Temperature value converted	0	°C/°F	-999...999	R	Temp_X5_Circ1
5138	137	---	Temperature value converted	0	°C/°F	-999...999	R	Temp_X6_Circ1
5139	138	---	Temperature value converted	0	°C/°F	-999...999	R	Temp_X7_Circ1
5140	139	---	Temperature value converted	0	°C/°F	-999...999	R	Temp_Y0_Circ1
5141	140	---	Temperature value converted	0	°C/°F	-999...999	R	Temp_Y1_Circ1
5142	141	---	Temperature value converted	0	°C/°F	-999...999	R	Temp_Y3_Circ1
5143	142	---	Temperature value converted	0	°C/°F	-999...999	R	Temp_Y2_Circ1
5144	143	---	Temperature value converted	0	°C/°F	-999...999	R	Temp_Y4_Circ1
5145	144	---	Temperature value converted	0	°C/°F	-999...999	R	Temp_Y5_Circ1
5146	145	---	Temperature value converted	0	°C/°F	-999...999	R	Temp_Y6_Circ1
5147	146	---	Temperature value converted	0	°C/°F	-999...999	R	Temp_Y7_Circ1
5148	147	---	Temperature value converted	0	°C/°F	-999...999	R	Temp_X0_Circ2
5149	148	---	Temperature value converted	0	°C/°F	-999...999	R	Temp_X1_Circ2

MB Index	Carel index	Par. code	Description	Def.	UOM	Range	R/W	Variable name
5150	149	---	Temperature value converted	0	°C/°F	-999...999	R	Temp_X2_Circ2
5151	150	---	Temperature value converted	0	°C/°F	-999...999	R	Temp_X3_Circ2
5152	151	---	Temperature value converted	0	°C/°F	-999...999	R	Temp_X4_Circ2
5153	152	---	Temperature value converted	0	°C/°F	-999...999	R	Temp_X5_Circ2
5154	153	---	Temperature value converted	0	°C/°F	-999...999	R	Temp_X6_Circ2
5155	154	---	Temperature value converted	0	°C/°F	-999...999	R	Temp_X7_Circ2
5156	155	---	Temperature value converted	0	°C/°F	-999...999	R	Temp_Y0_Circ2
5157	156	---	Temperature value converted	0	°C/°F	-999...999	R	Temp_Y1_Circ2
5158	157	---	Temperature value converted	0	°C/°F	-999...999	R	Temp_Y2_Circ2
5159	158	---	Temperature value converted	0	°C/°F	-999...999	R	Temp_Y3_Circ2
5160	159	---	Temperature value converted	0	°C/°F	-999...999	R	Temp_Y4_Circ2
5161	160	---	Temperature value converted	0	°C/°F	-999...999	R	Temp_Y5_Circ2
5162	161	---	Temperature value converted	0	°C/°F	-999...999	R	Temp_Y6_Circ2
5163	162	---	Temperature value converted	0	°C/°F	-999...999	R	Temp_Y7_Circ2
5164	163	---	Temperature value converted	0	°C/°F	-999...999	R	Temp_X0_Circ3
5165	164	---	Temperature value converted	0	°C/°F	-999...999	R	Temp_X1_Circ3
5166	165	---	Temperature value converted	0	°C/°F	-999...999	R	Temp_X2_Circ3
5167	166	---	Temperature value converted	0	°C/°F	-999...999	R	Temp_X3_Circ3
5168	167	---	Temperature value converted	0	°C/°F	-999...999	R	Temp_X4_Circ3
5169	168	---	Temperature value converted	0	°C/°F	-999...999	R	Temp_X5_Circ3
5170	169	---	Temperature value converted	0	°C/°F	-999...999	R	Temp_X6_Circ3
5171	170	---	Temperature value converted	0	°C/°F	-999...999	R	Temp_X7_Circ3
5172	171	---	Temperature value converted	0	°C/°F	-999...999	R	Temp_X0_Circ4
5173	172	---	Temperature value converted	0	°C/°F	-999...999	R	Temp_X2_Circ4
5174	173	---	Temperature value converted	0	°C/°F	-999...999	R	Temp_X1_Circ4
5175	174	---	Temperature value converted	0	°C/°F	-999...999	R	Temp_X3_Circ4
5176	175	---	Temperature value converted	0	°C/°F	-999...999	R	Temp_X4_Circ4
5177	176	---	Temperature value converted	0	°C/°F	-999...999	R	Temp_X5_Circ4
5178	177	---	Temperature value converted	0	°C/°F	-999...999	R	Temp_X6_Circ4
5179	178	---	Temperature value converted	0	°C/°F	-999...999	R	Temp_X7_Circ4
5180	179	---	Temperature value converted	0	°C/°F	-999...999	R	Temp_Y0_Circ3
5181	180	---	Temperature value converted	0	°C/°F	-999...999	R	Temp_Y1_Circ3
5182	181	---	Temperature value converted	0	°C/°F	-999...999	R	Temp_Y2_Circ3
5183	182	---	Temperature value converted	0	°C/°F	-999...999	R	Temp_Y3_Circ3
5184	183	---	Temperature value converted	0	°C/°F	-999...999	R	Temp_Y5_Circ3
5185	184	---	Temperature value converted	0	°C/°F	-999...999	R	Temp_Y4_Circ3
5186	185	---	Temperature value converted	0	°C/°F	-999...999	R	Temp_Y7_Circ3
5187	186	---	Temperature value converted	0	°C/°F	-999...999	R	Temp_Y6_Circ3
5188	187	---	Temperature value converted	0	°C/°F	-999...999	R	Temp_Y0_Circ4
5189	188	---	Temperature value converted	0	°C/°F	-999...999	R	Temp_Y1_Circ4
5190	189	---	Temperature value converted	0	°C/°F	-999...999	R	Temp_Y2_Circ4
5191	190	---	Temperature value converted	0	°C/°F	-999...999	R	Temp_Y4_Circ4
5192	191	---	Temperature value converted	0	°C/°F	-999...999	R	Temp_Y3_Circ4
5193	192	---	Temperature value converted	0	°C/°F	-999...999	R	Temp_Y5_Circ4
5194	193	---	Temperature value converted	0	°C/°F	-999...999	R	Temp_Y6_Circ4
5195	194	---	Temperature value converted	0	°C/°F	-999...999	R	Temp_Y7_Circ4
5209	208	E006	BMS Adress	1	---	0...207	R/W	Adress_BMS
5210	209	E009	BMS2 adress	1	---	0...207	R/W	Adress_BMS2
5211	210	---	Antifreeze heater output channel	0	---	0...99	R	AFreezeHeatPos
5212	211	A041	Antifreeze management	0	---	0...2	R/W	AFreezeMng
5213	212	C039	Antifreeze condenser alarm delay time at 1K below thrsh	60	s	5...300	R/W	AI_FreezeCondT_1K
5214	213	A030	Antifreeze alarm delay time at 1K below thrsh	60	s	5...300	R/W	AI_FreezeT_1K
5215	214	E015	Analogue output test channel	1	---	0...6	R/W	AOut_TestPos
5216	215	E005	BMS speed	4	---	0...4	R/W	Baudrate_BMS
5217	216	E008	BMS2 baudrate	4	---	0...4	R/W	Baudrate_BMS2
5218	217	Da77	Number of circuit in the unit	1	---	1...4	R/W	CircNo
5219	218	---	Position Compressor 1 circuit 1 direct start	0	---	0...99	R	Comp1Circ1DeltaPwA_DirectPos
5220	219	---	Reset Inverter alarms compressor 1 circuit 1	0	---	0...32767	R	Comp1Circ1InvAlrmResPos
5221	220	---	Emergency shutdown Inverter compressor 1 circuit 1	0	---	0...32767	R	Comp1Circ1InvEmergShOffPos
5222	221	---	Start signal Inverter compressor 1 circuit 1	0	---	0...32767	R	Comp1Circ1InvStartPos
5223	222	---	Compressor 1 running phase circuit 1	0	---	0...99	R	Comp1Circ1PhaseRun
5224	223	---	Rotation request compressor 1 circuit 1	0	%	0...999	R	Comp1Circ1RotInt
5225	224	---	Position Compressor 1 circuit 1 start or PartWinding B	0	---	0...99	R	Comp1Circ1StarPwB_Pos
5226	225	---	Position Compressor 1 valve 1 circuit 1	0	---	0...99	R	Comp1Circ1Vlv1Pos
5227	226	---	Position Compressor 1 valve 2 circuit 1	0	---	0...99	R	Comp1Circ1Vlv2Pos
5228	227	---	Position Compressor 1 valve 3 circuit 1	0	---	0...99	R	Comp1Circ1Vlv3Pos
5229	228	---	Position Compressor 1 valve 4 circuit 1	0	---	0...99	R	Comp1Circ1Vlv4Pos
5230	229	---	Position Compressor 1 circuit 2 direct start	0	---	0...99	R	Comp1Circ2DeltaPwA_DirectPos
5231	230	---	Reset Inverter alarms compressor 1 circuit 2	0	---	0...32767	R	Comp1Circ2InvAlrmResPos
5232	231	---	Emergency shutdown Inverter compressor 1 circuit 2	0	---	0...32767	R	Comp1Circ2InvEmergShOffPos
5233	232	---	Start signal Inverter compressor 1 circuit 2	0	---	0...32767	R	Comp1Circ2InvStartPos
5234	233	---	Compressor 1 running phase circuit 2	0	%	0...99	R	Comp1Circ2PhaseRun
5235	234	---	Rotation request compressor 1 circuit 2	0	%	0...999	R	Comp1Circ2RotInt
5236	235	---	Position Compressor 1 circuit 2 start or PartWinding B	0	---	0...99	R	Comp1Circ2StarPwB_Pos
5237	236	---	Position Compressor 1 valve 1 circuit 2	0	---	0...99	R	Comp1Circ2Vlv1Pos
5238	237	---	Position Compressor 1 valve 2 circuit 2	0	---	0...99	R	Comp1Circ2Vlv2Pos
5239	238	---	Position Compressor 1 valve 3 circuit 2	0	---	0...99	R	Comp1Circ2Vlv3Pos
5240	239	---	Position Compressor 1 valve 4 circuit 2	0	---	0...99	R	Comp1Circ2Vlv4Pos

MB Index	Carel index	Par. code	Description	Def.	UOM	Range	R/W	Variable name
5241	240	---	Position Compressor 1 circuit 3 direct start	0	---	0...99	R	Comp1Circ3DeltaPwA_DirectPos
5242	241	---	Reset Inverter alarms compressor 1 circuit 3	0	---	0...32767	R	Comp1Circ3InvAlrmResPos
5243	242	---	Emergency shutdown Inverter compressor 1 circuit 3	0	---	0...32767	R	Comp1Circ3InvEmergShOffPos
5244	243	---	Start signal Inverter compressor 1 circuit 3	0	---	0...32767	R	Comp1Circ3InvStartPos
5245	244	---	Compressor 1 running phase circuit 3	0	---	0...99	R	Comp1Circ3PhaseRun
5246	245	---	Rotation request compressor 1 circuit 3	0	%	0...999	R	Comp1Circ3RotInt
5247	246	---	Position Compressor 1 circuit 3 start or PartWinding B	0	---	0...99	R	Comp1Circ3StarPwB_Pos
5248	247	---	Position Compressor 1 valve 1 circuit 3	0	---	0...99	R	Comp1Circ3Vlv1Pos
5249	248	---	Position Compressor 1 valve 2 circuit 3	0	---	0...99	R	Comp1Circ3Vlv2Pos
5250	249	---	Position Compressor 1 valve 3 circuit 3	0	---	0...99	R	Comp1Circ3Vlv3Pos
5251	250	---	Position Compressor 1 valve 4 circuit 3	0	---	0...99	R	Comp1Circ3Vlv4Pos
5252	251	---	Position Compressor 1 circuit 4 direct start	0	---	0...99	R	Comp1Circ4DeltaPwA_DirectPos
5253	252	---	Reset Inverter alarms compressor 1 circuit 4	0	---	0...32767	R	Comp1Circ4InvAlrmResPos
5254	253	---	Emergency shutdown Inverter compressor 1 circuit 4	0	---	0...32767	R	Comp1Circ4InvEmergShOffPos
5255	254	---	Start signal Inverter compressor 1 circuit 4	0	---	0...32767	R	Comp1Circ4InvStartPos
5256	255	---	Compressor 1 running phase circuit 4	0	---	0...99	R	Comp1Circ4PhaseRun
5257	256	---	Rotation request compressor 1 circuit 4	0	%	0...999	R	Comp1Circ4RotInt
5258	257	---	Position Compressor 1 circuit 4 start or PartWinding B	0	---	0...99	R	Comp1Circ4StarPwB_Pos
5259	258	---	Position Compressor 1 valve 1 circuit 4	0	---	0...99	R	Comp1Circ4Vlv1Pos
5260	259	---	Position Compressor 1 valve 2 circuit 4	0	---	0...99	R	Comp1Circ4Vlv2Pos
5261	260	---	Position Compressor 1 valve 3 circuit 4	0	---	0...99	R	Comp1Circ4Vlv3Pos
5262	261	---	Position Compressor 1 valve 4 circuit 4	0	---	0...99	R	Comp1Circ4Vlv4Pos
5263	262	Da84	Compressor manufacturer	1	---	0...5	R/W	CompManuf
5264	263	Da84	Compressor model	1	---	0...99	R/W	CompModel
5265	264	---	Compressor type (visualization only)	0	---	0...9	R	CompTyp_Msk
5266	265	---	Position Condenser fan 1 circuit 1	0	---	0...32767	R	CondFan1Circ1Pos
5267	266	---	Position Condenser fan 1 circuit 2	0	---	0...32767	R	CondFan1Circ2Pos
5268	267	---	Position Condenser fan 1 circuit 3	0	---	0...32767	R	CondFan1Circ3Pos
5269	268	---	Position Condenser fan 1 circuit 4	0	---	0...32767	R	CondFan1Circ4Pos
5270	269	---	Position Condenser fan 2 circuit 1	0	---	0...32767	R	CondFan2Circ1Pos
5271	270	---	Position Condenser fan 2 circuit 2	0	---	0...32767	R	CondFan2Circ2Pos
5272	271	---	Position Condenser fan 2 circuit 3	0	---	0...32767	R	CondFan2Circ3Pos
5273	272	---	Position Condenser fan 2 circuit 4	0	---	0...32767	R	CondFan2Circ4Pos
5274	273	---	Position Condenser fan 3 circuit 1	0	---	0...32767	R	CondFan3Circ1Pos
5275	274	---	Position Condenser fan 3 circuit 2	0	---	0...32767	R	CondFan3Circ2Pos
5276	275	---	Position Condenser fan 3 circuit 3	0	---	0...32767	R	CondFan3Circ3Pos
5277	276	---	Position Condenser fan 3 circuit 4	0	---	0...32767	R	CondFan3Circ4Pos
5278	277	C017	Condenser fan startup delay in chiller mode	240	s	30...600	R/W	CondFanStartupT_CH
5279	278	C045	Number of condenser pumps	1	---	1...2	R/W	CondPmpNo
5280	279	---	Number condenser pump On	0	---	0...9	R	CondPmpNoOn
5281	280	C013	Condenser pumps rotation time	12	h	1...99	R/W	CondPmpRotT
5282	281	Da50	Current probe type	2	---	0...5	R/W	CurrentPrbTyp
5283	282	E003	Date format	1	---	1...3	R/W	DateFormat
5284	283	Da76	Devices unload sequence type	1	---	1...2	R/W	DevUnlSeq
5285	284	C035	Defrost interval time	20	min	0...999	R/W	DfrIntervalT
5286	285	C032	Defrost maximum time	5	min	1...999	R/W	DfrMaxT
5287	286	C031	Defrost minimum time	1	min	0...999	R/W	DfrMinT
5288	287	---	Number of defrost phase actually running circuit 1	0	---	0...9	R	DfrPhaseRunCirc1
5289	288	---	Number of defrost phase actually running circuit 2	0	---	0...99	R	DfrPhaseRunCirc2
5290	289	---	Number of defrost phase actually running circuit 3	0	---	0...9	R	DfrPhaseRunCirc3
5291	290	---	Number of defrost phase actually running circuit 4	0	---	0...9	R	DfrPhaseRunCirc4
5292	291	C030	Defrost startup delay	300	s	1...9999	R/W	DfrStartupT
5293	292	C036	Defrost synchronization type	0	---	0...2	R/W	DfrSynchTyp
5294	293	E013	Digital output test channel	1	---	0...30	R/W	DOut_TestPos
5295	294	C033	Dripping time	30	s	0...999	R/W	DripT
5296	295	Da19	High current alarm delay	20	s	0...999	R/W	DT_AIHiCurr
5297	296	Da18	High discharge pressure delay	40	s	0...999	R/W	DT_AIHiDscgP
5298	297	Da21	High suction pressure alarm run delay	60	s	0...999	R/W	DT_AIHiSuctP_Run
5299	298	Da20	High suction pressure alarm startup delay	120	s	0...999	R/W	DT_AIHiSuctP_Startup
5300	299	Da25	Low delta pressure alarm run delay	20	s	0...999	R/W	DT_AILowDP_Run
5301	300	Da24	Low delta pressure alarm startup delay	45	s	0...999	R/W	DT_AILowDP_Startup
5302	301	Da27	Low discharge pressure alarm run delay	60	s	0...999	R/W	DT_AILowDscgP_Run
5303	302	Da26	Low discharge pressure alarm startup delay	180	s	0...999	R/W	DT_AILowDscgP_Startup
5304	303	Da23	Low pressure ratio alarm run delay	20	s	0...999	R/W	DT_AILowP_RatioRun
5305	304	Da22	Low pressure ratio alarm startup delay	60	s	0...999	R/W	DT_AILowP_RatioStartup
5306	305	Da29	Low suction pressure alarm run delay	60	s	0...999	R/W	DT_AILowSuctP_Run
5307	306	Da28	Low suction pressure alarm startup delay	180	s	0...999	R/W	DT_AILowSuctP_Startup
5308	307	A010	Changeover delay	60	min	0...99	R/W	DT_ChgOver
5309	308	C012	Condenser pump delay OFF	10	s	0...999	R/W	DT_CondPmpOff
5310	309	C011	Delay from Condenser pump ON to start regulation	30	s	0...999	R/W	DT_CondPmpOn
5311	310	C010	Condenser pump flow alarm run delay	3	s	0...999	R/W	DT_CondPmpRunFlw
5312	311	C009	Condenser pump flow alarm startup delay	15	s	0...999	R/W	DT_CondPmpStartupFlw
5313	312	A024	Evaporator pump delay OFF	10	s	0...999	R/W	DT_EvapPmpOff
5314	313	A023	Delay from evaporator pump ON to start regulation	60	s	0...999	R/W	DT_EvapPmpOn
5315	314	A022	Evaporator pump flow alarm run delay	2	s	0...999	R/W	DT_EvapPmpRunFlw
5316	315	A021	Evaporator pump flow alarm startup delay	20	s	0...999	R/W	DT_EvapPmpStartupFlw
5317	316	Da15	Low pressure alarm run delay	10	s	0...999	R/W	DT_LP_PstatRun
5318	317	Da14	Low pressure alarm startup delay	40	s	0...999	R/W	DT_LP_PstatStartup
5319	318	Da17	Oil level alarm run delay	15	s	0...999	R/W	DT_OilLevRun

MB Index	Carel index	Par. code	Description	Def.	UOM	Range	R/W	Variable name
5320	319	Da16	Oil level alarm startup delay	30	s	0...999	R/W	DT_OilLevStartUp
5321	320	A012	Startup PID --> Run PID delay	180	s	0...9999	R/W	DT_StartupRunPID
5322	321	D57	Step 1 - Step 2 delay	10	s	0...9999	R/W	DTStep1Step2
5323	322	D58	Step 2 - Step 3 delay	10	s	0...9999	R/W	DTStep2Step3
5324	323	D59	Step 3 - Step 4 delay	10	s	0...9999	R/W	DTStep3Step4
5325	324	---	Position Eco compressor 1 circuit 1	0	---	0...99	R	EcoComp1Circ1Pos
5326	325	---	Position Eco compressor 1 circuit 2	0	---	0...99	R	EcoComp1Circ2Pos
5327	326	---	Position Eco compressor 1 circuit 3	0	---	0...99	R	EcoComp1Circ3Pos
5328	327	---	Position Eco compressor 1 circuit 4	0	---	0...99	R	EcoComp1Circ4Pos
5329	328	---	Position Digital output value of evaporator pump 1	0	---	0...99	R	EvapPmp1Pos
5330	329	---	Position Digital output value of evaporator pump 2	0	---	0...99	R	EvapPmp2Pos
5331	330	A043	Number of evaporator pumps	1	---	1...2	R/W	EvapPmpNo
5332	331	---	Number evaporator pump On	0	---	0...9	R	EvapPmpNoOn
5333	332	A025	Evaporator pumps rotation time	12	h	0...99	R/W	EvapPmpRotT
5334	333	B056	Manual valve position - Circ3	0	---	0...9999	R/W	EVO3_I39_MANUAL_POSIT_STEPS
5335	334	---	EVD status circuit 3	0	---	1...100	R	EVO3_I8_REG_STATUS_msk
5336	335	B058	Manual valve position - Circ4	0	---	0...9999	R/W	EVO4_I39_MANUAL_POSIT_STEPS
5337	336	---	EVD status circuit 4	0	---	1...100	R	EVO4_I8_REG_STATUS_msk
5338	337	Da11	Force rotation interval time	2	h	0...9	R/W	FrcRotT
5339	338	---	Position General alarm	0	---	0...32767	R	GenAlrmPos
5340	339	Da42	Ignition type	1	---	0...2	R/W	IgnitionTyp
5341	340	Da10	Compressor load down time	30	s	0...999	R/W	LdDwnT
5342	341	Da99	Delay between steps activation	20	s	0...999	R/W	LdStepsDT
5343	342	Da09	Compressor load up time	300	s	0...999	R/W	LdUpT
5344	343	---	Position Liquid injection compressor 1 circuit 1	0	---	0...99	R	LiqdInjComp1Circ1Pos
5345	344	---	Position Liquid injection compressor 1 circuit 2	0	---	0...99	R	LiqdInjComp1Circ2Pos
5346	345	---	Position Liquid injection compressor 1 circuit 3	0	---	0...99	R	LiqdInjComp1Circ3Pos
5347	346	---	Position Liquid injection compressor 1 circuit 4	0	---	0...99	R	LiqdInjComp1Circ4Pos
5348	347	D57	Max power reach time for stepless control	60	s	0...9999	R/W	MaxPwrDT
5349	348	Da30	Max retry per hour for low suction pressur alarm	3	---	1...9	R/W	MaxRetryAIOWSuctIP
5350	349	D58	MinInputValue of Min time OFF compressor	60	s	0...32767	R/W	MinMinOffT
5351	350	D57	MinInputValue of Min time between ON of the same compressor	360	s	0...32767	R/W	MinMinOnOnSameT
5352	351	D59	MinInputValue of Min time ON compressor	240	s	0...32767	R/W	MinMinOnT
5353	352	Da06	Min time OFF compressor after alarm	180	s	0...9999	R/W	MinOffAlrmT
5354	353	Da05	Min time OFF compressor	180	s	0...9999	R/W	MinOffRegT
5355	354	Da08	Min time between ON of the same compressor	600	s	0...9999	R/W	MinOnOnSameT
5356	355	Da07	Min time ON compressor	300	s	0...9999	R/W	MinOnT
5357	356	D56	Min power reach time for stepless control	60	s	0...9999	R/W	MinPwrDT
5358	357	C075	Fans number	1	---	1...3	R/W	N_Fans
5359	358	D510	Compressor OFF: Valve 1 command type	1	---	0...5	R/W	OffCmdVlv1
5360	359	D520	Compressor OFF: Valve 2 command type	1	---	0...5	R/W	OffCmdVlv2
5361	360	D530	Compressor OFF: Valve 3 command type	1	---	0...5	R/W	OffCmdVlv3
5362	361	D540	Compressor OFF: Valve 4 command type	1	---	0...5	R/W	OffCmdVlv4
5363	362	D513	Compressor phase 1: Valve 1 command type	1	---	0...5	R/W	Phase1CmdVlv1
5364	363	D523	Compressor phase 1: Valve 2 command type	1	---	0...5	R/W	Phase1CmdVlv2
5365	364	D533	Compressor phase 1: Valve 3 command type	1	---	0...5	R/W	Phase1CmdVlv3
5366	365	D543	Compressor phase 1: Valve 4 command type	1	---	0...5	R/W	Phase1CmdVlv4
5367	366	D514	Compressor phase 2: Valve 1 command type	1	---	0...5	R/W	Phase2CmdVlv1
5368	367	D524	Compressor phase 2: Valve 2 command type	1	---	0...5	R/W	Phase2CmdVlv2
5369	368	D534	Compressor phase 2: Valve 3 command type	1	---	0...5	R/W	Phase2CmdVlv3
5370	369	D544	Compressor phase 2: Valve 4 command type	1	---	0...5	R/W	Phase2CmdVlv4
5371	370	D515	Compressor phase 3: Valve 1 command type	1	---	0...5	R/W	Phase3CmdVlv1
5372	371	D525	Compressor phase 3: Valve 2 command type	1	---	0...5	R/W	Phase3CmdVlv2
5373	372	D535	Compressor phase 3: Valve 3 command type	1	---	0...5	R/W	Phase3CmdVlv3
5374	373	D545	Compressor phase 3: Valve 4 command type	1	---	0...5	R/W	Phase3CmdVlv4
5375	374	D516	Compressor phase 4: Valve 1 command type	1	---	0...5	R/W	Phase4CmdVlv1
5376	375	D526	Compressor phase 4: Valve 2 command type	1	---	0...5	R/W	Phase4CmdVlv2
5377	376	D536	Compressor phase 4: Valve 3 command type	1	---	0...5	R/W	Phase4CmdVlv3
5378	377	D546	Compressor phase 4: Valve 4 command type	1	---	0...5	R/W	Phase4CmdVlv4
5379	378	B007	Integral time SH regulation in chiller mode	150	s	0...1000	R/W	PID_TICH
5380	379	B011	Integral time SH regulation in heating mode	150	s	0...1000	R/W	PID_TIHP
5381	380	B036	Maximum pumpdown time	20	s	0...999	R/W	PmpDwnMaxT
5382	381	B037	Pumpdown type	0	---	0...2	R/W	PmpDwnTyp
5383	382	B039	Pumpdown valve configuration	3	---	0...3	R/W	PmpDwnVlvCfg
5384	383	C034	Post dripping time	30	s	0...999	R/W	PostDripT
5388	387	Da31	Prevent time for compressor step	30	s	0...32767	R/W	PreventT
5389	388	E004	Protocol type on BMS port	2	---	0...3	R/W	Protocol_BMS
5390	389	E007	Protocol type on slave port BMS2	2	---	0...3	R/W	Protocol_BMS2
5391	390	Da39	Compressor ignition: Winding A to B delay time	500	ms	0...32767	R/W	PwDT
5392	391	A014	Tau par. for exponential distribution on temp. Regulation	5	s	1...999	R/W	RegTau
5393	392	---	Position 4way valve circuit 1	0	---	0...99	R	RevVlvCirc1Pos
5394	393	---	Position 4way valve circuit 2	0	---	0...99	R	RevVlvCirc2Pos
5395	394	---	Position 4way valve circuit 3	0	---	0...99	R	RevVlvCirc3Pos
5396	395	---	Position 4way valve circuit 4	0	---	0...99	R	RevVlvCirc4Pos
5397	396	C027	Reverse cycle time	20	s	0...999	R/W	RevVlvT
5398	397	Da78	Refrigerant type	1	---	0...22	R/W	RfrgTyp
5399	398	Da75	Rotation type	1	---	1...3	R/W	RotTyp
5400	399	A020	Run regulation derivative time	5	s	0...9999	R/W	RunTempRegTd

MB Index	Carel index	Par. code	Description	Def.	UOM	Range	R/W	Variable name
5401	400	A019	Run regulation integral time	40	s	0...9999	R/W	RunTempRegTi
5402	401	Db17	Compressor shutdown phase 1: Valve 1 command type	1	---	0...5	R/W	ShOff1CmdVlv1
5403	402	Db27	Compressor shutdown phase 1: Valve 2 command type	1	---	0...5	R/W	ShOff1CmdVlv2
5404	403	Db37	Compressor shutdown phase 1: Valve 3 command type	1	---	0...5	R/W	ShOff1CmdVlv3
5405	404	Db47	Compressor shutdown phase 1: Valve 4 command type	1	---	0...5	R/W	ShOff1CmdVlv4
5406	405	Db18	Compressor shutdown phase 2: Valve 1 command type	1	---	0...5	R/W	ShOff2CmdVlv1
5407	406	Db28	Compressor shutdown phase 2: Valve 2 command type	1	---	0...5	R/W	ShOff2CmdVlv2
5408	407	Db38	Compressor shutdown phase 2: Valve 3 command type	1	---	0...5	R/W	ShOff2CmdVlv3
5409	408	Db48	Compressor shutdown phase 2: Valve 4 command type	1	---	0...5	R/W	ShOff2CmdVlv4
5410	409	Db63	Compressor shutdown phase 2 time	0	s	0...9999	R/W	ShOff2T
5411	410	Db51	Compressor shutdown phase 1 time	10	s	0...9999	R/W	ShOffT
5412	411	---	Position Solenoid valve circuit 1	0	---	0...99	R	SolVlvCirc1Pos
5413	412	---	Position Solenoid valve circuit 2	0	---	0...99	R	SolVlvCirc2Pos
5414	413	---	Position Solenoid valve circuit 3	0	---	0...99	R	SolVlvCirc3Pos
5415	414	---	Position Solenoid valve circuit 4	0	---	0...99	R	SolVlvCirc4Pos
5416	415	Da40	Star/delta time delay [ms]	20	ms	0...32767	R/W	StarDeltaDT
5417	416	Da41	Star relay activation time [ms]	1000	ms	0...32767	R/W	StarT
5418	417	B033	Startup valve opening % (capacity ratio EVAP / EEV) - Chiller mode	80	%	0...100	R/W	StartEEV_OpenRatioCH
5419	418	B034	Startup valve opening % (capacity ratio EVAP / EEV) - HeatPump mode	75	%	0...100	R/W	StartEEV_OpenRatioHP
5420	419	Db11	Compressor startup phase 1: Valve 1 command type	1	---	0...5	R/W	StartUp1CmdVlv1
5421	420	Db21	Compressor startup phase 1: Valve 2 command type	1	---	0...5	R/W	StartUp1CmdVlv2
5422	421	Db31	Compressor startup phase 1: Valve 3 command type	1	---	0...5	R/W	StartUp1CmdVlv3
5423	422	Db41	Compressor startup phase 1: Valve 4 command type	1	---	0...5	R/W	StartUp1CmdVlv4
5424	423	Db12	Compressor startup phase 2: Valve 1 command type	1	---	0...5	R/W	StartUp2CmdVlv1
5425	424	Db22	Compressor startup phase 2: Valve 2 command type	1	---	0...5	R/W	StartUp2CmdVlv2
5426	425	Db32	Compressor startup phase 2: Valve 3 command type	1	---	0...5	R/W	StartUp2CmdVlv3
5427	426	Db42	Compressor startup phase 2: Valve 4 command type	1	---	0...5	R/W	StartUp2CmdVlv4
5428	427	Db61	Compressor startup phase 2 time	0	s	0...9999	R/W	StartUp2T
5429	428	Db50	Compressor startup phase 1 time	10	s	0...9999	R/W	StartUpT
5430	429	A017	Startup regulation derivative time	0	s	0...9999	R/W	StartupTempRegTd
5431	430	A016	Startup regulation integral time	180	s	0...9999	R/W	StartupTempRegTi
5432	431	Db53	Number of compressor steps	1	---	1...4	R/W	StepNo
5433	432	---	Unit status	0	---	0...9	R	UnitStatus
5434	433	A042	Type of the unit	1	---	0...2	R/W	UnitTyp
5435	434	Db04	Compressor valves intermittent time	1	s	1...99	R/W	VlvBlinkT
5436	435	Db01	Valve number	1	---	1...4	R/W	VlvNo
5437	436	Da33	Pulsing valve Max time OFF	12	s	2...999	R/W	VlvPlsOfft_Max
5438	437	Da32	Pulsing valve Min time OFF	3	s	2...999	R/W	VlvPlsOfft_Min
5439	438	B041	Output relay configuration	2	---	1...6	R/W	I12_RELE_CONFIG_msk
5440	439	B043	Valve type	1	---	1...22	R/W	I14_SUPER_EEV_TYPE_msk
5441	440	B044	Regulation type	1	---	0...21	R/W	I15_SUPER_MAIN_REGULATION_msk
5442	441	B045	EEV minimum steps	50	---	0...9999	R/W	I30_EEV_REG_MIN_POS_msk
5443	442	B046	EEV maximum steps	480	---	0...9999	R/W	I31_EEV_REG_MAX_POS_msk
5444	443	B048	EEV move rate	50	---	1...2000	R/W	I32_EEV_MOVE_RATE_msk
5445	444	B050	EEV move current	450	---	0...800	R/W	I33_EEV_MOVE_CURRENT_msk
5446	445	B052	EEV duty cycle	30	---	1...100	R/W	I34_EEV_MOVE_DUTY_msk
5447	446	B051	EEV hold current	100	---	0...800	R/W	I35_EEV_HOLD_CURRENT_msk
5448	447	B047	EEV full close steps	500	---	0...9999	R/W	I36_EEV_FULLCLOSE_STEP_S_msk
5449	448	B002	Manual valve position - Circ1	0	---	0...9999	R/W	I39_MANUAL_POSIT_STEPS_msk
5450	449	A049	High water temperature startup delay	15	min	0...99	R/W	DT_HighWaterTemp_Startup
5451	450	B026	Low evaporation temperature alarm delay	300	---	0...18000	R/W	I41_LOP_ALARM_DELAY_msk
5452	451	B027	MOP: high temperature evaporation alarm delay	600	---	0...18000	R/W	I42_MOP_ALARM_DELAY_msk
5453	452	B025	LowSH: low superheat alarm delay	300	---	0...18000	R/W	I43_LOW_SH_ALARM_DELAY_msk
5454	453	B030	High condensing temperature alarm delay	600	---	0...18000	R/W	I44_HITCOND_ALARM_DELAY_msk
5455	454	B049	Rate for fast valve closig (in case of power failure)	150	---	1...2000	R/W	I86_EEV_FAST_CLOS_MOVE_RATE_msk
5456	455	B032	Alarm delay low suction temperature	300	---	0...18000	R/W	I9_LOW_SUCTION_ALARM_DELAY_msk
5457	456	B040	Regulation delay after power-on	6	---	0...18000	R/W	I90_SH_WAIT_DELAY_msk
5458	457	Da55	Probe type suction pressure	0	---	0...3	R/W	S1_Probe_Type_msk
5459	458	Da58	Probe type suction temperature	0	---	0...3	R/W	S2_Probe_Type_msk
5460	459	Da65	Probe type discharge pressure	0	---	0...3	R/W	S3_Probe_Type_msk
5461	460	Da68	Probe type discharge temperature	0	---	0...2	R/W	S4_Probe_Type_msk
5462	461	B004	Manual valve position - Circ2	0	---	0...9999	R/W	I39_MANUAL_POSIT_STEPS_msk
5463	462	A050	High water temperature run delay	180	2	0...999	R/W	DT_HighWaterTemp_Run
5464	463	E017	Default installation	0	---	0...1	R/W	Msk_Default_Init
5465	464	Dc08	Inverter compressor StartUp time	30	s	0...999	R/W	InvStartUpT
5466	465	Dc09	Inverter compressor ShutOff time	30	s	0...999	R/W	InvShOffT
5467	466	Dc11	Inverter compressor address comp1 circ1	1	---	1...255	R/W	Comp1Circ1_InvAddr
5468	467	Dc12	Inverter compressor address comp1 circ2	2	---	1...255	R/W	Comp1Circ2_InvAddr

8.3 Digital variables

MB Index	Carel index	Par. code	Description	Def.	UOM	Range	R/W	Variable name
1	1	---	Compressor 1 circuit 1 Direct/PartWinding A/Delta relay	0	---	0...1	R	Comp1Circ1DeltaDirectPwA
2	2	---	Compressor 1 circuit 2 Direct/PartWinding A/Delta relay	0	---	0...1	R	Comp1Circ2DeltaDirectPwA
3	3	---	Compressor 1 circuit 4 Direct/PartWinding A/Delta relay	0	---	0...1	R	Comp1Circ4DeltaDirectPwA
4	4	---	Compressor 1 circuit 3 Direct/PartWinding A/Delta relay	0	---	0...1	R	Comp1Circ3DeltaDirectPwA
5	5	---	Compressor 1 circuit 2 Star/PartWinding B relay	0	---	0...1	R	Comp1Circ2StarPwB
6	6	---	Compressor 1 circuit 1 Star/PartWinding B relay	0	---	0...1	R	Comp1Circ1StarPwB
7	7	---	Compressor 1 circuit 4 Star/PartWinding B relay	0	---	0...1	R	Comp1Circ4StarPwB
8	8	---	Compressor 1 circuit 3 Star/PartWinding B relay	0	---	0...1	R	Comp1Circ3StarPwB
9	9	---	Inverter start request compressor 1 circuit 1	0	---	0...1	R	Comp1Circ1InvStart
10	10	---	Inverter start request compressor 1 circuit 2	0	---	0...1	R	Comp1Circ2InvStart
11	11	---	Inverter start request compressor 1 circuit 4	0	---	0...1	R	Comp1Circ4InvStart
12	12	---	Inverter start request compressor 1 circuit 3	0	---	0...1	R	Comp1Circ3InvStart
13	13	---	Reset Inverter alarms compressor 1 circuit 1	0	---	0...1	R	Comp1Circ1InvAlrmRes
14	14	---	Reset Inverter alarms compressor 1 circuit 2	0	---	0...1	R	Comp1Circ2InvAlrmRes
15	15	---	Reset Inverter alarms compressor 1 circuit 4	0	---	0...1	R	Comp1Circ4InvAlrmRes
16	16	---	Reset Inverter alarms compressor 1 circuit 3	0	---	0...1	R	Comp1Circ3InvAlrmRes
17	17	---	Immediate Shutoff of compressor inverter 1	0	---	0...1	R	Comp1Circ1InvEmergShOff
18	18	---	Immediate Shutoff of compressor	0	---	0...1	R	Comp1Circ2InvEmergShOff
19	19	---	Immediate Shutoff of compressor	0	---	0...1	R	Comp1Circ4InvEmergShOff
20	20	---	Immediate Shutoff of compressor	0	---	0...1	R	Comp1Circ3InvEmergShOff
21	21	---	Solenoid valve circuit 1 status	0	---	0...1	R	SolVlvCirc1
22	22	---	Solenoid valve circuit 2 status	0	---	0...1	R	SolVlvCirc2
23	23	---	Solenoid valve circuit 3 status	0	---	0...1	R	SolVlvCirc3
24	24	---	Solenoid valve circuit 4 status	0	---	0...1	R	SolVlvCirc4
25	25	---	Status of 4way valve circuit 1	0	---	0...1	R	RevVlvCirc1
26	26	---	Status of 4way valve circuit 2	0	---	0...1	R	RevVlvCirc2
27	27	---	Status of 4way valve circuit 3	0	---	0...1	R	RevVlvCirc3
28	28	---	Status of 4way valve circuit 4	0	---	0...1	R	RevVlvCirc4
29	29	---	Eco compressor 1 relay circuit 1	0	---	0...1	R	EcoComp1Circ1
30	30	---	Eco compressor 1 circuit 2 relay	0	---	0...1	R	EcoComp1Circ2
31	31	---	Eco compressor 1 relay circuit 3	0	---	0...1	R	EcoComp1Circ3
32	32	---	Eco compressor 1 relay circuit 4	0	---	0...1	R	EcoComp1Circ4
33	33	---	Liquid injection compressor 1 circuit 1 status	0	---	0...1	R	LiqdInjComp1Circ1
34	34	---	Liquid injection compressor 1 circuit 2 status	0	---	0...1	R	LiqdInjComp1Circ2
35	35	---	Liquid injection compressor 1 circuit 3 status	0	---	0...1	R	LiqdInjComp1Circ3
36	36	---	Liquid injection compressor 1 circuit 4 status	0	---	0...1	R	LiqdInjComp1Circ4
37	37	---	Condenser 1 status	0	---	0...1	R	Cond1_On
38	38	---	Condenser 2 status	0	---	0...1	R	Cond2_On
39	39	---	Condenser 3 status	0	---	0...1	R	Cond3_On
40	40	---	Condenser 4 status	0	---	0...1	R	Cond4_On
41	41	---	Condenser fan 2 status circuit 1	0	---	0...1	R	CondFan2Circ1_On
42	42	---	Condenser fan 2 status circuit 2	0	---	0...1	R	CondFan2Circ2_On
43	43	---	Condenser fan 2 status circuit 3	0	---	0...1	R	CondFan2Circ3_On
44	44	---	Condenser fan 2 status circuit 4	0	---	0...1	R	CondFan2Circ4_On
45	45	---	Condenser fan 3 status circuit 1	0	---	0...1	R	CondFan3Circ1_On
46	46	---	Condenser fan 3 status circuit 2	0	---	0...1	R	CondFan3Circ2_On
47	47	---	Condenser fan 3 status circuit 3	0	---	0...1	R	CondFan3Circ3_On
48	48	---	Condenser fan 3 status circuit 4	0	---	0...1	R	CondFan3Circ4_On
49	49	---	Evaporator pump 1 status	0	---	0...1	R	EvapPmp1On
50	50	---	Evaporator pump 2 status	0	---	0...1	R	EvapPmp2On
51	51	---	Antifreeze heater relay	0	---	0...1	R	AFreezeHeat
52	52	---	Free cooling valve status	0	---	0...1	R	FC_VlvOn
53	53	---	General alarm	0	---	0...1	R	GenAlrm
54	54	---	Low pressure switch circuit 1 status	0	---	0...1	R	Circ1_LP_Pstat
55	55	---	Low pressure switch status circuit 2	0	---	0...1	R	Circ2_LP_Pstat
56	56	---	Low pressure switch circuit 4 status	0	---	0...1	R	Circ4_LP_Pstat
57	57	---	Low pressure switch circuit 3 status	0	---	0...1	R	Circ3_LP_Pstat
58	58	---	Oil level circuit 1	0	---	0...1	R	Circ1_OilLev
59	59	---	Oil level circuit 2	0	---	0...1	R	Circ2_OilLev
60	60	---	Oil level circuit 4	0	---	0...1	R	Circ4_OilLev
61	61	---	Oil level circuit 3	0	---	0...1	R	Circ3_OilLev
62	62	---	High pressure switch status circuit 1	0	---	0...1	R	Circ1_HP_Pstat
63	63	---	High pressure switch status circuit 2	0	---	0...1	R	Circ2_HP_Pstat
64	64	---	High pressure switch status circuit 4	0	---	0...1	R	Circ4_HP_Pstat
65	65	---	High pressure switch status circuit 3	0	---	0...1	R	Circ3_HP_Pstat
66	66	---	Overload of compressor 1 circuit 1	0	---	0...1	R	OvldComp1Circ1
67	67	---	Overload of compressor 1 circuit 2	0	---	0...1	R	OvldComp1Circ2
68	68	---	Overload of compressor 1 circuit 4	0	---	0...1	R	OvldComp1Circ4
69	69	---	Overload of compressor 1 circuit 3	0	---	0...1	R	OvldComp1Circ3
70	70	---	Inverter RUN feedback compressor 1 circuit 1	0	---	0...1	R	Comp1Circ1InvRun
71	71	---	Inverter RUN feedback compressor 1 circuit 2	0	---	0...1	R	Comp1Circ2InvRun
72	72	---	Inverter RUN feedback compressor 1 circuit 3	0	---	0...1	R	Comp1Circ3InvRun
73	73	---	Inverter RUN feedback compressor 1 circuit 4	0	---	0...1	R	Comp1Circ4InvRun
74	74	---	Inverter alarm signal compressor 1 circuit 1	0	---	0...1	R	Comp1Circ1InvAlrm
75	75	---	Inverter alarm signal compressor 1 circuit 2	0	---	0...1	R	Comp1Circ2InvAlrm
76	76	---	Inverter alarm signal compressor 1 circuit 3	0	---	0...1	R	Comp1Circ3InvAlrm
77	77	---	Inverter alarm signal compressor 1 circuit 4	0	---	0...1	R	Comp1Circ4InvAlrm
78	78	---	Evaporator Flow switch status	0	---	0...1	R	EvapFlwSw

79	79	---	Evaporator pump 1 overload	0	---	0...1	R	EvapPmp1Ovld
80	80	---	Evaporator pump 2 overload	0	---	0...1	R	EvapPmp2Ovld
81	81	---	Condenser Flow switch status	0	---	0...1	R	CondFlwSw
82	82	---	Condenser 1 overload	0	---	0...1	R	Cond1Ovld
83	83	---	Condenser 2 overload	0	---	0...1	R	Cond2Ovld
84	84	---	Condenser 3 overload	0	---	0...1	R	Cond3Ovld
85	85	---	Condenser 4 overload	0	---	0...1	R	Cond4Ovld
86	86	---	Remote alarm	0	---	0...1	R	RemoteAl
87	87	---	Summer/Winter selection by digital input	0	---	0...1	R	RemoteCoolHeat
88	88	---	Remote ON/OFF	0	---	0...1	R	RemoteOn
89	89	---	BMS ON/OFF	1	---	0...1	R/W	BmsOn
90	90	---	Enable Setpoint by BMS	0	---	0...1	R/W	BMS_En_SetP_Change
91	91	Q004	Cooling/heating (Summer/winter) by keyboard	0	---	0...1	R/W	KeybCoolHeat
92	92	E001	Unit of measurement for temperature (0: °C; 1: °F)	0	---	0...1	R/W	UnitMeasTemp
93	93	E002	Unit of measurement for pressure (0: barg; 1: psig)	0	---	0...1	R/W	UnitMeasPress
94	94	---	Regulation probe type running	0	---	0...1	R	RegTypPrb
95	95	---	Reset alarm	0	---	0...1	R/W	ResAlarm
96	96	---	Alarm active circuit 1	0	---	0...1	R	OrAlCirc1
97	97	---	Alarm active circuit 2	0	---	0...1	R	OrAlCirc2
98	98	---	Alarm active circuit 3	0	---	0...1	R	OrAlCirc3
99	99	---	Alarm active circuit 4	0	---	0...1	R	OrAlCirc4
100	100	---	Unit is ON	0	---	0...1	R	SysOn
101	101	---	Air/Water unit	0	---	0...1	R	UnitAirW
102	102	Q001	Request unit On by keyboard	0	---	0...1	R/W	KeybOnOff
208	208	---	Digital output status of antifreeze heater	0	---	0...1	R	AFreezeHeatVal
209	209	A040	Antifreeze digital output logic	0	---	0...1	R/W	AFreezeLogic
210	210	C048	Air circuit type	1	---	0...1	R/W	AirFlowType
211	211	---	Low battery alarm EVD circuit 1	0	---	0...1	R	Al_BattEvdCirc1
212	212	---	Low battery alarm EVD circuit 2	0	---	0...1	R	Al_BattEvdCirc2
213	213	---	Low battery alarm EVD circuit 3	0	---	0...1	R	Al_BattEvdCirc3
214	214	---	Low battery alarm EVD circuit 4	0	---	0...1	R	Al_BattEvdCirc4
215	215	---	Configuration error alarm EVD circuit 1	0	---	0...1	R	Al_CfgErrEvdCirc1
216	216	---	Configuration error alarm EVD circuit 2	0	---	0...1	R	Al_CfgErrEvdCirc2
217	217	---	Configuration error alarm EVD circuit 3	0	---	0...1	R	Al_CfgErrEvdCirc3
218	218	---	Configuration error alarm EVD circuit 4	0	---	0...1	R	Al_CfgErrEvdCirc4
219	219	---	Clock alarm	0	---	0...1	R	AL_Clock
220	220	---	Clock alarm Slave board	0	---	0...1	R	AL_ClockSlv
221	221	---	Compressor 1 maintenance alarm circuit 1	0	---	0...1	R	Al_Comp1Circ1Hrs
222	222	---	Compressor 1 maintenance alarm circuit 2	0	---	0...1	R	Al_Comp1Circ2Hrs
223	223	---	Compressor 1 maintenance alarm circuit 3	0	---	0...1	R	Al_Comp1Circ3Hrs
224	224	---	Compressor 1 maintenance alarm circuit 4	0	---	0...1	R	Al_Comp1Circ4Hrs
225	225	---	Condenser 1 maintenance alarm	0	---	0...1	R	Al_Cond1Hrs
226	226	---	Condenser 2 maintenance alarm	0	---	0...1	R	Al_Cond2Hrs
227	227	---	Condenser 3 maintenance alarm	0	---	0...1	R	Al_Cond3Hrs
228	228	---	Condenser 4 maintenance alarm	0	---	0...1	R	Al_Cond4Hrs
229	229	---	Condenser fan 1 overload alarm	0	---	0...1	R	Al_CondFan1Ovld
230	230	---	Condenser fan 2 circuit 1 maintenance alarm	0	---	0...1	R	Al_CondFan2Circ1Hrs
231	231	---	Condenser fan 2 circuit 2 maintenance alarm	0	---	0...1	R	Al_CondFan2Circ2Hrs
232	232	---	Condenser fan 2 circuit 3 maintenance alarm	0	---	0...1	R	Al_CondFan2Circ3Hrs
233	233	---	Condenser fan 2 circuit 4 maintenance alarm	0	---	0...1	R	Al_CondFan2Circ4Hrs
234	234	---	Condenser fan 2 overload alarm	0	---	0...1	R	Al_CondFan2Ovld
235	235	---	Condenser fan 3 circuit 1 maintenance alarm	0	---	0...1	R	Al_CondFan3Circ1Hrs
236	236	---	Condenser fan 3 circuit 2 maintenance alarm	0	---	0...1	R	Al_CondFan3Circ2Hrs
237	237	---	Condenser fan 3 circuit 3 maintenance alarm	0	---	0...1	R	Al_CondFan3Circ3Hrs
238	238	---	Condenser fan 3 circuit 4 maintenance alarm	0	---	0...1	R	Al_CondFan3Circ4Hrs
239	239	---	Condenser fan 3 overload alarm	0	---	0...1	R	Al_CondFan3Ovld
240	240	---	Condenser fan 4 overload alarm	0	---	0...1	R	Al_CondFan4Ovld
241	241	---	High condensing temperature alarm EVD circuit 1	0	---	0...1	R	Al_CondHiTempCirc1
242	242	---	Condensing high temperature alarm EVD circuit 2	0	---	0...1	R	Al_CondHiTempCirc2
243	243	---	High condensing temperature alarm EVD circuit 3	0	---	0...1	R	Al_CondHiTempCirc3
244	244	---	Condensing high temperature alarm EVD circuit 4	0	---	0...1	R	Al_CondHiTempCirc4
245	245	---	Condenser pumps group alarm - compressor shutoff immediately	0	---	0...1	R	Al_CondPmp
246	246	---	Condenser pump 1 flow alarm	0	---	0...1	R	Al_CondPmp1Flw
247	247	---	Condenser pump 1 overload alarm	0	---	0...1	R	Al_CondPmp1Ovld
248	248	---	Condenser pump 2 flow alarm	0	---	0...1	R	Al_CondPmp2Flw
249	249	---	Condenser pump 2 overload alarm	0	---	0...1	R	Al_CondPmp2Ovld
250	250	---	EEPROM Alarm EVD circuit 1	0	---	0...1	R	Al_EEPROM_EvdCirc1
251	251	---	EEPROM Alarm EVD circuit 2	0	---	0...1	R	Al_EEPROM_EvdCirc2
252	252	---	EEPROM Alarm EVD circuit 3	0	---	0...1	R	Al_EEPROM_EvdCirc3
253	253	---	EEPROM Alarm EVD circuit 4	0	---	0...1	R	Al_EEPROM_EvdCirc4
254	254	---	EEV motor alarm EVD circuit 1	0	---	0...1	R	Al_EEV_Circ1
255	255	---	EEV motor alarm EVD circuit 2	0	---	0...1	R	Al_EEV_Circ2
256	256	---	EEV motor alarm EVD circuit 3	0	---	0...1	R	Al_EEV_Circ3
257	257	---	EEV motor alarm EVD circuit 4	0	---	0...1	R	Al_EEV_Circ4
258	258	---	Alarm status for valve emergency closing EVD circuit 1	0	---	0...1	R	Al_EmergClosingEvdCirc1
259	259	---	Alarm status for valve emergency closing EVD circuit 2	0	---	0...1	R	Al_EmergClosingEvdCirc2
260	260	---	Alarm status for valve emergency closing EVD circuit 3	0	---	0...1	R	Al_EmergClosingEvdCirc3
261	261	---	Alarm status for valve emergency closing EVD circuit 4	0	---	0...1	R	Al_EmergClosingEvdCirc4
262	262	---	Evaporator pump group alarm - comp is shut off immediately	0	---	0...1	R	Al_EvapPmp
263	263	---	Evaporator pump 1 flow alarm	0	---	0...1	R	Al_EvapPmp1Flw
264	264	---	Evaporator pump 1 maintenance alarm	0	---	0...1	R	Al_EvapPmp1Hrs
265	265	---	Evaporator pump 1 overload alarm	0	---	0...1	R	Al_EvapPmp1Ovld

266	266	---	Evaporator pump 2 flow alarm	0	---	0...1	R	AI_EvapPmp2Flw
267	267	---	Evaporator pump 2 maintenance alarm	0	---	0...1	R	AI_EvapPmp2Hrs
268	268	---	Evaporator pump 2 overload alarm	0	---	0...1	R	AI_EvapPmp2Ovld
269	269	---	P-Memory expansion alarm or is absent	0	---	0...1	R	AI_ExtIdMemory
270	270	---	P-Memory expansion alarm or is absent in Slave board	0	---	0...1	R	AI_ExtIdMemorySlv
271	271	---	Antifreeze alarm evaporator 1	0	---	0...1	R	AI_FreezeEvap1
272	272	---	Antifreeze alarm evaporator 2	0	---	0...1	R	AI_FreezeEvap2
273	273	---	Antifreeze alarm evaporator 3	0	---	0...1	R	AI_FreezeEvap3
274	274	---	Antifreeze alarm evaporator 4	0	---	0...1	R	AI_FreezeEvap4
275	275	---	Firmware not compatible alarm EVD circuit 1	0	---	0...1	R	AI_FWNtOkEvdCirc1
276	276	---	Firmware not compatible alarm EVD circuit 2	0	---	0...1	R	AI_FWNtOkEvdCirc2
277	277	---	Firmware not compatible alarm EVD circuit 3	0	---	0...1	R	AI_FWNtOkEvdCirc3
278	278	---	Firmware not compatible alarm EVD circuit 4	0	---	0...1	R	AI_FWNtOkEvdCirc4
279	279	---	Alarm high current circuit 1	0	---	0...1	R	AI_HiCurrCirc1
280	280	---	Alarm high current circuit 2	0	---	0...1	R	AI_HiCurrCirc2
281	281	---	Alarm high current circuit 3	0	---	0...1	R	AI_HiCurrCirc3
282	282	---	Alarm high current circuit 4	0	---	0...1	R	AI_HiCurrCirc4
283	283	---	High discharge pressure alarm circuit 1	0	---	0...1	R	AI_HiDscgP_Circ1
284	284	---	High discharge pressure alarm circuit 2	0	---	0...1	R	AI_HiDscgP_Circ2
285	285	---	High discharge pressure alarm circuit 3	0	---	0...1	R	AI_HiDscgP_Circ3
286	286	---	High discharge pressure alarm circuit 4	0	---	0...1	R	AI_HiDscgP_Circ4
287	287	---	High discharge temperature alarm circuit 1	0	---	0...1	R	AI_HiDscgTempCirc1
288	288	---	High discharge temperature alarm circuit 2	0	---	0...1	R	AI_HiDscgTempCirc2
289	289	---	High discharge temperature alarm circuit 3	0	---	0...1	R	AI_HiDscgTempCirc3
290	290	---	High discharge temperature alarm circuit 4	0	---	0...1	R	AI_HiDscgTempCirc4
291	291	---	Alarm high pressure ratio circuit 1	0	---	0...1	R	AI_HiP_RatioCirc1
292	292	---	Alarm high pressure ratio circuit 2	0	---	0...1	R	AI_HiP_RatioCirc2
293	293	---	Alarm high pressure ratio circuit 3	0	---	0...1	R	AI_HiP_RatioCirc3
294	294	---	Alarm high pressure ratio circuit 4	0	---	0...1	R	AI_HiP_RatioCirc4
295	295	---	High suction pressure alarm by transducer circuit 1	0	---	0...1	R	AI_HiSuctP_Circ1
296	296	---	High suction pressure alarm by transducer circuit 2	0	---	0...1	R	AI_HiSuctP_Circ2
297	297	---	High suction pressure alarm by transducer circuit 3	0	---	0...1	R	AI_HiSuctP_Circ3
298	298	---	High suction pressure alarm by transducer circuit 4	0	---	0...1	R	AI_HiSuctP_Circ4
299	299	---	High pressure alarm by pressure switch circuit 1	0	---	0...1	R	AI_HP_PstatCirc1
300	300	---	High pressure alarm by pressure switch circuit 2	0	---	0...1	R	AI_HP_PstatCirc2
301	301	---	High pressure alarm by pressure switch circuit 3	0	---	0...1	R	AI_HP_PstatCirc3
302	302	---	High pressure alarm by pressure switch circuit 4	0	---	0...1	R	AI_HP_PstatCirc4
303	303	---	Incomplete valve closing alarm EVD circuit 1	0	---	0...1	R	AI_IncompleteClosingEvdCirc1
304	304	---	Incomplete valve closing alarm EVD circuit 2	0	---	0...1	R	AI_IncompleteClosingEvdCirc2
305	305	---	Incomplete valve closing alarm EVD circuit 3	0	---	0...1	R	AI_IncompleteClosingEvdCirc3
306	306	---	Incomplete valve closing alarm EVD circuit 4	0	---	0...1	R	AI_IncompleteClosingEvdCirc4
307	307	---	Alarm Inverter compressor 1 circuit 1	0	---	0...1	R	AI_InvComp1Circ1
308	308	---	Alarm Inverter compressor 1 circuit 2	0	---	0...1	R	AI_InvComp1Circ2
309	309	---	Alarm Inverter compressor 1 circuit 3	0	---	0...1	R	AI_InvComp1Circ3
310	310	---	Alarm Inverter compressor 1 circuit 4	0	---	0...1	R	AI_InvComp1Circ4
311	311	---	Light alarm circuit 1	0	---	0...1	R	AI_LigCirc1_Msk
312	312	---	Light alarm circuit 2	0	---	0...1	R	AI_LigCirc2_Msk
313	313	---	LOP (low temperature of evaporation) alarm EVD circuit 1	0	---	0...1	R	AI_LOP_Circ1
314	314	---	LOP (low temperature of evaporation) alarm EVD circuit 2	0	---	0...1	R	AI_LOP_Circ2
315	315	---	LOP (low temperature of evaporation) alarm EVD circuit 3	0	---	0...1	R	AI_LOP_Circ3
316	316	---	LOP (low temperature of evaporation) alarm EVD circuit 4	0	---	0...1	R	AI_LOP_Circ4
317	317	---	Alarm low delta pressure circuit 1	0	---	0...1	R	AI_LowDP_Circ1
318	318	---	Alarm low delta pressure circuit 2	0	---	0...1	R	AI_LowDP_Circ2
319	319	---	Alarm low delta pressure circuit 3	0	---	0...1	R	AI_LowDP_Circ3
320	320	---	Alarm low delta pressure circuit 4	0	---	0...1	R	AI_LowDP_Circ4
321	321	---	Low discharge pressure alarm by envelope circuit 1	0	---	0...1	R	AI_LowDscgP_Circ1
322	322	---	Low discharge pressure alarm by envelope circuit 2	0	---	0...1	R	AI_LowDscgP_Circ2
323	323	---	Low discharge pressure alarm by envelope circuit 3	0	---	0...1	R	AI_LowDscgP_Circ3
324	324	---	Low discharge pressure alarm by envelope circuit 4	0	---	0...1	R	AI_LowDscgP_Circ4
325	325	---	Alarm low pressure ratio circuit 1	0	---	0...1	R	AI_LowP_RatioCirc1
326	326	---	Alarm low pressure ratio circuit 2	0	---	0...1	R	AI_LowP_RatioCirc2
327	327	---	Alarm low pressure ratio circuit 3	0	---	0...1	R	AI_LowP_RatioCirc3
328	328	---	Alarm low pressure ratio circuit 4	0	---	0...1	R	AI_LowP_RatioCirc4
329	329	---	LowSH (low super heat) alarm EVD circuit 1	0	---	0...1	R	AI_LowSH_Circ1
330	330	---	LowSH (low super heat) alarm EVD circuit 2	0	---	0...1	R	AI_LowSH_Circ2
331	331	---	LowSH (low super heat) alarm EVD circuit 3	0	---	0...1	R	AI_LowSH_Circ3
332	332	---	LowSH (low super heat) alarm EVD circuit 4	0	---	0...1	R	AI_LowSH_Circ4
333	333	---	Low suction temperature alarm EVD circuit 1	0	---	0...1	R	AI_LowSuctCirc1
334	334	---	Low suction temperature alarm EVD circuit 2	0	---	0...1	R	AI_LowSuctCirc2
335	335	---	Low suction temperature alarm EVD circuit 3	0	---	0...1	R	AI_LowSuctCirc3
336	336	---	Low suction temperature alarm EVD circuit 4	0	---	0...1	R	AI_LowSuctCirc4
337	337	---	Low suction pressure alarm by transducer circuit 1	0	---	0...1	R	AI_LowSuctP_Circ1
338	338	---	Low suction pressure alarm by transducer circuit 2	0	---	0...1	R	AI_LowSuctP_Circ2
339	339	---	Low suction pressure alarm by transducer circuit 3	0	---	0...1	R	AI_LowSuctP_Circ3
340	340	---	Low suction pressure alarm by transducer circuit 4	0	---	0...1	R	AI_LowSuctP_Circ4
341	341	---	Low pressure alarm by pressure switch circuit 1	0	---	0...1	R	AI_LP_PstatCirc1
342	342	---	Low pressure alarm by pressure switch circuit 2	0	---	0...1	R	AI_LP_PstatCirc2
343	343	---	Low pressure alarm by pressure switch circuit 3	0	---	0...1	R	AI_LP_PstatCirc3

344	344	---	Low pressure alarm by pressure switch circuit 4	0	---	0...1	R	AI_LP_PstatCirc4
345	345	---	MOP alarm EVD circuit 1	0	---	0...1	R	AI_MOP_Circ1
346	346	---	MOP alarm EVD circuit 2	0	---	0...1	R	AI_MOP_Circ2
347	347	---	MOP alarm EVD circuit 3	0	---	0...1	R	AI_MOP_Circ3
348	348	---	MOP alarm EVD circuit 4	0	---	0...1	R	AI_MOP_Circ4
349	349	---	Driver offline alarm EVD circuit 1	0	---	0...1	R	AI_OfflineEvdCirc1
350	350	---	Driver offline alarm EVD circuit 2	0	---	0...1	R	AI_OfflineEvdCirc2
351	351	---	Driver offline alarm EVD circuit 3	0	---	0...1	R	AI_OfflineEvdCirc3
352	352	---	Driver offline alarm EVD circuit 4	0	---	0...1	R	AI_OfflineEvdCirc4
353	353	---	Oil level alarm circuit 1	0	---	0...1	R	AI_OilLevCirc1
354	354	---	Oil level alarm circuit 2	0	---	0...1	R	AI_OilLevCirc2
355	355	---	Oil level alarm circuit 3	0	---	0...1	R	AI_OilLevCirc3
356	356	---	Oil level alarm circuit 4	0	---	0...1	R	AI_OilLevCirc4
357	357	---	Compressor 1 overload alarm circuit 1	0	---	0...1	R	AI_OvrlComp1Circ1
358	358	---	Compressor 1 overload alarm circuit 2	0	---	0...1	R	AI_OvrlComp1Circ2
359	359	---	Compressor 1 overload alarm circuit 3	0	---	0...1	R	AI_OvrlComp1Circ3
360	360	---	Compressor 1 overload alarm circuit 4	0	---	0...1	R	AI_OvrlComp1Circ4
361	361	---	Alarm probe 1	0	---	0...1	R	AI_Prb1
362	362	---	Alarm probe 1 Slave board	0	---	0...1	R	AI_Prb1Slv
363	363	---	Alarm probe 2	0	---	0...1	R	AI_Prb2
364	364	---	Alarm probe 2 Slave board	0	---	0...1	R	AI_Prb2Slv
365	365	---	Alarm Probe 3	0	---	0...1	R	AI_Prb3
366	366	---	Alarm Probe 3 Slave board	0	---	0...1	R	AI_Prb3Slv
367	367	---	Alarm Probe 4	0	---	0...1	R	AI_Prb4
368	368	---	Alarm Probe 4 Slave board	0	---	0...1	R	AI_Prb4Slv
369	369	---	Alarm Probe 5	0	---	0...1	R	AI_Prb5
370	370	---	Alarm Probe 5 Slave board	0	---	0...1	R	AI_Prb5Slv
371	371	---	Alarm Probe 6	0	---	0...1	R	AI_Prb6
372	372	---	Alarm Probe 6 Slave board	0	---	0...1	R	AI_Prb6Slv
373	373	---	Discharge pressure probe alarm circuit 1	0	---	0...1	R	AI_PrbDscgP_Circ1
374	374	---	Discharge pressure probe alarm circuit 2	0	---	0...1	R	AI_PrbDscgP_Circ2
375	375	---	Discharge pressure probe alarm circuit 3	0	---	0...1	R	AI_PrbDscgP_Circ3
376	376	---	Discharge pressure probe alarm circuit 4	0	---	0...1	R	AI_PrbDscgP_Circ4
377	377	---	Discharge temperature probe alarm circuit 1	0	---	0...1	R	AI_PrbDscgT_Circ1
378	378	---	Discharge temperature probe alarm circuit 2	0	---	0...1	R	AI_PrbDscgT_Circ2
379	379	---	Discharge temperature probe alarm circuit 3	0	---	0...1	R	AI_PrbDscgT_Circ3
380	380	---	Discharge temperature probe alarm circuit 4	0	---	0...1	R	AI_PrbDscgT_Circ4
381	381	---	Suction pressure probe alarm circuit 1	0	---	0...1	R	AI_PrbSuctP_Circ1
382	382	---	Suction pressure probe alarm circuit 2	0	---	0...1	R	AI_PrbSuctP_Circ2
383	383	---	Suction pressure probe alarm circuit 3	0	---	0...1	R	AI_PrbSuctP_Circ3
384	384	---	Suction pressure probe alarm circuit 4	0	---	0...1	R	AI_PrbSuctP_Circ4
385	385	---	Suction temperature probe alarm circuit 1	0	---	0...1	R	AI_PrbSuctT_Circ1
386	386	---	Suction temperature probe alarm circuit 2	0	---	0...1	R	AI_PrbSuctT_Circ2
387	387	---	Suction temperature probe alarm circuit 3	0	---	0...1	R	AI_PrbSuctT_Circ3
388	388	---	Suction temperature probe alarm circuit 4	0	---	0...1	R	AI_PrbSuctT_Circ4
389	389	---	Serious alarm circuit 1	0	---	0...1	R	AI_SerCirc1_Msk
390	390	---	Serious alarm circuit 2	0	---	0...1	R	AI_SerCirc2_Msk
391	391	---	Specify if slave offline (0: No alarm; 1: Alarm)	0	---	0...1	R	AI_Slave_Offline
392	392	---	Unit alarm	0	---	0...1	R	AI_Unit
393	393	A009	Summer/winter changeover type	0	---	0...1	R/W	ChgOverKey
394	394	---	Digital output value of Reset Inverter alarms compressor 1 circuit 1	0	---	0...1	R	Comp1Circ1InvAlrmResVal
395	395	---	Digital output value of Immediate Shutoff of compressor	0	---	0...1	R	Comp1Circ1InvEmergShOffVal
396	396	---	Compressor 1 valve 1 relay circuit 1	0	---	0...1	R	Comp1Circ1Vlv1
397	397	---	Compressor 1 valve 2 relay circuit 1	0	---	0...1	R	Comp1Circ1Vlv2
398	398	---	Compressor 1 valve 3 relay circuit 1	0	---	0...1	R	Comp1Circ1Vlv3
399	399	---	Compressor 1 valve 4 relay circuit 1	0	---	0...1	R	Comp1Circ1Vlv4
400	400	---	Digital output value of Reset Inverter alarms compressor 1 circuit 2	0	---	0...1	R	Comp1Circ2InvAlrmResVal
401	401	---	Digital output value of Immediate Shutoff of compressor	0	---	0...1	R	Comp1Circ2InvEmergShOffVal
402	402	---	Compressor 1 circuit 2 valve 1 relay	0	---	0...1	R	Comp1Circ2Vlv1
403	403	---	Compressor 1 circuit 2 valve 2 relay	0	---	0...1	R	Comp1Circ2Vlv2
404	404	---	Compressor 1 circuit 2 valve 3 relay	0	---	0...1	R	Comp1Circ2Vlv3
405	405	---	Compressor 1 circuit 2 valve 4 relay	0	---	0...1	R	Comp1Circ2Vlv4
406	406	---	Digital output value of Reset Inverter alarms compressor 1 circuit 3	0	---	0...1	R	Comp1Circ3InvAlrmResVal
407	407	---	Digital output value of Immediate Shutoff of compressor	0	---	0...1	R	Comp1Circ3InvEmergShOffVal
408	408	---	Compressor 1 valve 1 relay circuit 3	0	---	0...1	R	Comp1Circ3Vlv1
409	409	---	Compressor 1 valve 2 relay circuit 3	0	---	0...1	R	Comp1Circ3Vlv2
410	410	---	Compressor 1 valve 3 relay circuit 3	0	---	0...1	R	Comp1Circ3Vlv3
411	411	---	Compressor 1 valve 4 relay circuit 3	0	---	0...1	R	Comp1Circ3Vlv4
412	412	---	Digital output value of Reset Inverter alarms compressor 1 circuit 4	0	---	0...1	R	Comp1Circ4InvAlrmResVal
413	413	---	Digital output value of Immediate Shutoff of compressor	0	---	0...1	R	Comp1Circ4InvEmergShOffVal
414	414	---	Compressor 1 valve 1 relay circuit 4	0	---	0...1	R	Comp1Circ4Vlv1
415	415	---	Compressor 1 valve 2 relay circuit 4	0	---	0...1	R	Comp1Circ4Vlv2
416	416	---	Compressor 1 valve 3 relay circuit 4	0	---	0...1	R	Comp1Circ4Vlv3
417	417	---	Compressor 1 valve 4 relay circuit 4	0	---	0...1	R	Comp1Circ4Vlv4
418	418	Da46	Compressor overload contact NO/NC logic	0	---	0...1	R/W	CompOvldLogic
419	419	---	Digital output status of condenser fan circuit 1	0	---	0...1	R	Cond1Val
420	420	---	Digital output status of condenser fan circuit 2	0	---	0...1	R	Cond2Val
421	421	---	Digital output status of condenser fan circuit 3	0	---	0...1	R	Cond3Val

422	422	---	Digital output status of condenser fan circuit 4	0	---	0...1	R	Cond4Val
423	423	---	Condenser fan 1 status circuit 1	0	---	0...1	R	CondFan1Circ1_On
424	424	---	Condenser fan 1 status circuit 2	0	---	0...1	R	CondFan1Circ2_On
425	425	---	Condenser fan 1 status circuit 3	0	---	0...1	R	CondFan1Circ3_On
426	426	---	Condenser fan 1 status circuit 4	0	---	0...1	R	CondFan1Circ4_On
427	427	---	Digital output status of condenser fan 2 circuit 1	0	---	0...1	R	CondFan2Circ1Val
428	428	---	Digital output status of condenser fan 2 circuit 2	0	---	0...1	R	CondFan2Circ2Val
429	429	---	Digital output status of condenser fan 2 circuit 3	0	---	0...1	R	CondFan2Circ3Val
430	430	---	Digital output status of condenser fan 2 circuit 4	0	---	0...1	R	CondFan2Circ4Val
431	431	---	Digital output status of condenser fan 3 circuit 1	0	---	0...1	R	CondFan3Circ1Val
432	432	---	Digital output status of condenser fan 3 circuit 2	0	---	0...1	R	CondFan3Circ2Val
433	433	---	Digital output status of condenser fan 3 circuit 3	0	---	0...1	R	CondFan3Circ3Val
434	434	---	Digital output status of condenser fan 3 circuit 4	0	---	0...1	R	CondFan3Circ4Val
435	435	C046	Condenser fan type	1	---	0...1	R/W	CondFanTyp
436	436	C043	Condenser flow switch NO/NC contact logic	0	---	0...1	R/W	CondFlwSwLogic
437	437	C044	Digital output logic of condenser fan	0	---	0...1	R/W	CondLogic
438	438	C042	Condenser fan/pump overload NO/NC contact logic	0	---	0...1	R/W	CondOvldLogic
439	439	---	Condenser pump 1 status	0	---	0...1	R	CondPmp1On
440	440	---	Condenser pump 2 status	0	---	0...1	R	CondPmp2On
441	441	---	Summer/Winter status	0	---	0...1	R	CoolHeat
442	442	---	EVD digital input 1 circuit 1	0	---	0...1	R	Din1_EvdCirc1
443	443	---	EVD digital input 1 circuit 2	0	---	0...1	R	Din1_EvdCirc2
444	444	---	EVD digital input 1 circuit 3	0	---	0...1	R	Din1_EvdCirc3
445	445	---	EVD digital input 1 circuit 4	0	---	0...1	R	Din1_EvdCirc4
446	446	---	Digital input 1 status	0	---	0...1	R	DIn1_Status
447	447	---	Digital input 10 status on Slave board	0	---	0...1	R	DIn10_Slv_Status
448	448	---	Digital input 10 status	0	---	0...1	R	DIn10_Status
449	449	---	Digital input 11 status on Slave board	0	---	0...1	R	DIn11_Slv_Status
450	450	---	Digital input 11 status	0	---	0...1	R	DIn11_Status
451	451	---	Digital input 12 status	0	---	0...1	R	DIn12_Status
452	452	---	Digital input 13 status on Slave board	0	---	0...1	R	DIn13_Slv_Status
453	453	---	Digital input 13 status	0	---	0...1	R	DIn13_Status
454	454	---	Digital input 14 status on Slave board	0	---	0...1	R	DIn14_Slv_Status
455	455	---	Digital input 14 status	0	---	0...1	R	DIn14_Status
456	456	---	EVD digital input 2 circuit 1	0	---	0...1	R	Din2_EvdCirc1
457	457	---	EVD digital input 2 circuit 2	0	---	0...1	R	Din2_EvdCirc2
458	458	---	EVD digital input 2 circuit 3	0	---	0...1	R	Din2_EvdCirc3
459	459	---	EVD digital input 2 circuit 4	0	---	0...1	R	Din2_EvdCirc4
460	460	---	Digital input 2 status	0	---	0...1	R	DIn2_Status
461	461	---	Digital input 3 status	0	---	0...1	R	DIn3_Status
462	462	---	Digital input 4 status	0	---	0...1	R	DIn4_Status
463	463	---	Digital input 5 status	0	---	0...1	R	DIn5_Status
464	464	---	Digital input 6 status on Slave board	0	---	0...1	R	DIn6_Slv_Status
465	465	---	Digital input 6 status	0	---	0...1	R	DIn6_Status
466	466	---	Digital input 7 status on Slave board	0	---	0...1	R	DIn7_Slv_Status
467	467	---	Digital input 7 status	0	---	0...1	R	DIn7_Status
468	468	---	Digital input 8 status on Slave board	0	---	0...1	R	DIn8_Slv_Status
469	469	---	Digital input 8 status	0	---	0...1	R	DIn8_Status
470	470	---	Digital input 9 status on Slave board	0	---	0...1	R	DIn9_Slv_Status
471	471	---	Digital input 9 status	0	---	0...1	R	DIn9_Status
472	472	E014	Digital output test value	0	---	0...1	R/W	DOUt_TestVal
473	473	---	Digital output value of Eco compressor 1 circuit 1	0	---	0...1	R	EcoComp1Circ1Val
474	474	---	Digital output status of Eco compressor 1 circuit 2	0	---	0...1	R	EcoComp1Circ2Val
475	475	---	Digital output value of Eco compressor 1 circuit 3	0	---	0...1	R	EcoComp1Circ3Val
476	476	---	Digital output value of Eco compressor 1 circuit 4	0	---	0...1	R	EcoComp1Circ4Val
477	477	Da48	Digital output logic of Economizer	0	---	0...1	R/W	EcoLogic
478	478	Da79	Enable current probe	0	---	0...1	R/W	En_CurrentPrb
479	479	Da81	Eco enable	0	---	0...1	R/W	En_Eco
480	480	Da80	Enable envelope prevent control	1	---	0...1	R/W	En_Env
481	481	A044	Enable Free Cooling with outdoor air (direct free-cooling)	0	---	0...1	R/W	En_FC_Air
482	482	E012	Enable IO test	0	---	0...1	R/W	En_IO_Test
483	483	Da82	Enable liquid injection	0	---	0...1	R/W	En_LiqdInj
484	484	B038	Enable liquid solenoid valve	1	---	0...1	R/W	En_SolVlv
485	485	A036	Evaporator flow switch NO/NC contact logic	0	---	0...1	R/W	EvapFlwSwLogic
486	486	A037	Evaporator pump overload NO/NC contact logic	0	---	0...1	R/W	EvapOvldLogic
487	487	---	Digital output status of evaporator pump 1	0	---	0...1	R	EvapPmp1Val
488	488	---	Digital output status of evaporator pump 2	0	---	0...1	R	EvapPmp2Val
489	489	A038	Digital output logic of evaporator pump	0	---	0...1	R/W	EvapPmpLogic
490	490	B055	Manual positioning enable - Circ3	0	---	0...1	R/W	EVO3_D24_MANUAL_POSIT_EN
491	491	B057	Manual positioning enable - Circ4	0	---	0...1	R/W	EVO4_D24_MANUAL_POSIT_EN
492	492	A047	Digital output logic of Free cooling valve	0	---	0...1	R/W	FC_VlvLogic
493	493	A039	Digital output logic of general alarm	0	---	0...1	R/W	GenAlrmLogic
494	494	---	Digital output status of general alarm	0	---	0...1	R	GenAlrmVal
495	495	Da45	High pressure from pressostat contact NO/NC logic	0	---	0...1	R/W	HP_PstatLogic
496	496	Dc01	Compressor inverter alarm contact NO/NC logic	0	---	0...1	R/W	InvAlrmLogic
497	497	Dc05	Inverter Alarm reset NO/NC contact logic	0	---	0...1	R/W	InvAlrmResLogic
498	498	Dc04	Inverter Emergency shut-off NO/NC contact logic	1	---	0...1	R/W	InvEmergShOffLogic
499	499	Dc02	Inverter RUN NO/NC contact logic	1	---	0...1	R/W	InvRunLogic
500	500	Dc03	Inverter Start NO/NC contact logic	0	---	0...1	R/W	InvStartLogic
501	501	E018	IO test board selection	0	---	0...1	R/W	IO_Test_Board
502	502	---	Digital output status of Liquid Injection compressor 1 circuit 1	0	---	0...1	R	LiqdInjComp1Circ1Val
503	503	---	Digital output status of Liquid Injection compressor 1 circuit 2	0	---	0...1	R	LiqdInjComp1Circ2Val

			circuit 2					
504	504	---	Digital output status of Liquid Injection compressor 1 circuit 3	0	---	0...1	R	LiqdInjComp1Circ3Val
505	505	---	Digital output status of Liquid Injection compressor 1 circuit 4	0	---	0...1	R	LiqdInjComp1Circ4Val
506	506	Da49	Digital output logic of Liquid injection	0	---	0...1	R/W	LiqdInjLogic
507	507	Da43	Low pressure from pressostat NO/NC contact logic	0	---	0...1	R/W	LP_PstatLogic
508	508	Da44	Oil level NO/NC contact logic	0	---	0...1	R/W	OilLevLogic
509	509	---	Pumpdown warning (End for max time) on circuit 1	0	---	0...1	R	PmpDwnCirc1_Warning
510	510	---	Pumpdown warning (End for max time) on circuit 2	0	---	0...1	R	PmpDwnCirc2_Warning
511	511	---	Pumpdown warning (End for max time) on circuit 3	0	---	0...1	R	PmpDwnCirc3_Warning
512	512	---	Pumpdown warning (End for max time) on circuit 4	0	---	0...1	R	PmpDwnCirc4_Warning
513	513	A013	Run regulation type	1	---	0...1	R/W	RegTypRun
514	514	A011	Startup regulation type	0	---	0...1	R/W	RegTypStartup
515	515	A033	Remote alarm NO/NC contact logic	0	---	0...1	R/W	RemoteAl_Logic
516	516	A034	Remote Summer/Winter NO/NC contact logic	0	---	0...1	R/W	RemoteCoolHeatLogic
517	517	A035	Remote On NO/NC contact logic	1	---	0...1	R/W	RemoteOnLogic
518	518	E010	Reset data logger	0	---	0...1	R/W	ResEvent
519	519	E011	Reset hour counters	0	---	0...1	R/W	ResHrs
520	520	---	Reset hour counters compressor 1 circuit 1	0	---	0...1	R/W	ResHrsComp1Circ1
521	521	---	Reset hour counters compressor 1 circuit 2	0	---	0...1	R/W	ResHrsComp1Circ2
522	522	---	Reset hour counters compressor 1 circuit 3	0	---	0...1	R/W	ResHrsComp1Circ3
523	523	---	Reset hour counters compressor 1 circuit 4	0	---	0...1	R/W	ResHrsComp1Circ4
524	524	---	Reset hour counters circuit 1 condenser fan 1	0	---	0...1	R/W	ResHrsCondFan1Circ1
525	525	---	Reset hour counters circuit 2 condenser fan 1	0	---	0...1	R/W	ResHrsCondFan1Circ2
526	526	---	Reset hour counters circuit 3 condenser fan 1	0	---	0...1	R/W	ResHrsCondFan1Circ3
527	527	---	Reset hour counters circuit 4 condenser fan 1	0	---	0...1	R/W	ResHrsCondFan1Circ4
528	528	---	Reset hour counters circuit 1 condenser fan 2	0	---	0...1	R/W	ResHrsCondFan2Circ1
529	529	---	Reset hour counters circuit 2 condenser fan 2	0	---	0...1	R/W	ResHrsCondFan2Circ2
530	530	---	Reset hour counters circuit 3 condenser fan 2	0	---	0...1	R/W	ResHrsCondFan2Circ3
531	531	---	Reset hour counters circuit 4 condenser fan 2	0	---	0...1	R/W	ResHrsCondFan2Circ4
532	532	---	Reset hour counters circuit 1 condenser fan 3	0	---	0...1	R/W	ResHrsCondFan3Circ1
533	533	---	Reset hour counters circuit 2 condenser fan 3	0	---	0...1	R/W	ResHrsCondFan3Circ2
534	534	---	Reset hour counters circuit 3 condenser fan 3	0	---	0...1	R/W	ResHrsCondFan3Circ3
535	535	---	Reset hour counters circuit 4 condenser fan 3	0	---	0...1	R/W	ResHrsCondFan3Circ4
536	536	---	Reset hour counters condenser pump 1	0	---	0...1	R/W	ResHrsCondPmp1
537	537	---	Reset hour counters condenser pump 2	0	---	0...1	R/W	ResHrsCondPmp2
538	538	---	Reset hour counters evaporator pump 1	0	---	0...1	R/W	ResHrsEvapPmp1
539	539	---	Reset hour counters evaporator pump 2	0	---	0...1	R/W	ResHrsEvapPmp2
540	540	---	Digital output value of 4way valve circuit 1	0	---	0...1	R	RevVlvCirc1Val
541	541	---	Digital output status of 4way valve circuit 2	0	---	0...1	R	RevVlvCirc2Val
542	542	---	Digital output value of 4way valve circuit 3	0	---	0...1	R	RevVlvCirc3Val
543	543	---	Digital output value of 4way valve circuit 4	0	---	0...1	R	RevVlvCirc4Val
544	544	Da47	Digital output logic of 4-way valve	0	---	0...1	R/W	RevVlvLogic
545	545	---	Shut down unit for prototype error	0	---	0...1	R	ShutdownUnit
546	546	---	Digital output value of solenoid valve circuit 1	0	---	0...1	R	SolVlvCirc1Val
547	547	---	Digital output status of solenoid valve circuit 2	0	---	0...1	R	SolVlvCirc2Val
548	548	---	Digital output value of solenoid valve circuit 3	0	---	0...1	R	SolVlvCirc3Val
549	549	---	Digital output value of solenoid valve circuit 4	0	---	0...1	R	SolVlvCirc4Val
550	550	B042	Digital output logic of solenoid valve	0	---	0...1	R/W	SolVlvLogic
551	551	C004	Switch-over condenser pumps	0	---	0...1	R/W	SwCondPmp
552	552	A004	Switch-over evaporator pumps	0	---	0...1	R/W	SwEvapPmp
553	553	C047	Water/Water unit	0	---	0...1	R/W	UnitWW
554	554	B001	Manual positioning enable - Circ1	0	---	0...1	R/W	D24_MANUAL_POSIT_ENAB LE_msk
555	555	B054	Closing valve position synchronization	1	---	0...1	R/W	D21_EEV_EXTRA_CLOSE_E NABLE_msk
556	556	B053	Opening valve position synchronization	1	---	0...1	R/W	D20_EEV_EXTRA_OPEN_E NABLE_msk
557	557	B003	Manual positioning enable - Circ2	0	---	0...1	R/W	D24_MANUAL_POSIT_ENAB LE_msk
558	558	---	Serious alarm circuit 3	0	---	0...1	R	Al_SerCirc3_Msk
559	559	---	Light alarm circuit 3	0	---	0...1	R	Al_LigCirc3_Msk
560	560	---	Serious alarm circuit 4	0	---	0...1	R	Al_SerCirc4_Msk
561	561	---	Light alarm circuit 4	0	---	0...1	R	Al_LigCirc4_Msk
562	562	---	Wrong Envelope data (Bad point coordinates assignment)	0	---	0...1	R	EnvDataErr
563	563	---	Compressor 1 circuit 1 status	0	---	0...1	R	Comp1Circ1_On
564	564	---	Compressor 1 circuit 2 status	0	---	0...1	R	Comp1Circ2_On
565	565	---	Compressor 1 circuit 3 status	0	---	0...1	R	Comp1Circ3_On
566	566	---	Compressor 1 circuit 4 status	0	---	0...1	R	Comp1Circ4_On
567	567	---	Enable second compressor	0	---	0...1	R	En_Comp1Circ2
568	568	---	Enable third compressor	0	---	0...1	R	En_Comp1Circ3
569	569	---	Enable fourth compressor	0	---	0...1	R	En_Comp1Circ4
570	570	---	Digital universal input 4 status	0	---	0...1	R	DUIn4_Status
571	571	---	Digital input 1 status on Slave board	0	---	0...1	R	DIn1_Slv_Status
572	572	---	Digital input 2 status on Slave board	0	---	0...1	R	DIn2_Slv_Status
573	573	---	Digital input 3 status on Slave board	0	---	0...1	R	DIn3_Slv_Status
574	574	---	Digital input 4 status on Slave board	0	---	0...1	R	DIn4_Slv_Status
575	575	---	Digital input 5 status on Slave board	0	---	0...1	R	DIn5_Slv_Status
576	576	---	Digital input 12 status on Slave board	0	---	0...1	R	DIn12_Slv_Status
577	577	---	NOT of condenser fan type	1	---	0...1	R	CondFanTyp_NOT
578	578	---	Number of fan enabled >= 2	0	---	0...1	R	En_Fan2
579	579	---	Number of fan enabled >= 3	0	---	0...1	R	En_Fan3
580	580	Dc10	Enable Modbus Master (3.0) inverter communication	0	---	0...1	R/W	En_MBM_Comm
581	581	---	High water temperature alarm	0	---	0...1	R	Al_HighWaterTemp

582	582	---	Free cooling anomaly	0	---	0...1	R	AI_FC_Anomaly
583	583	---	Inverter 1 offline (MBM 3.0)	0	---	0...1	R	MBM_Comp1_InvOffline
584	584	---	Inverter 2 offline (MBM 3.0)	0	---	0...1	R	MBM_Comp2_InvOffline
585	585	---	Inverter 1 alarm active (read by MBM3.0)	0	---	0...1	R	MBM_InvAlrmActive
586	586	---	Inverter 2 alarm active (read by MBM3.0)	0	---	0...1	R	MBM_InvAlrmActive

9. ALARMS

9.1 Alarms interface

9.1.1 Alarms screen and LEDs

Pressing the ALARM key can occur in two different situations - no alarm or an alarm present.

If there is no alarm, the following screen is displayed:



This screen makes it possible to easily enter the alarms log using the ENTER key.

If there is at least one alarm, the alarms screen is displayed sorted by alarm code from lesser to greater.

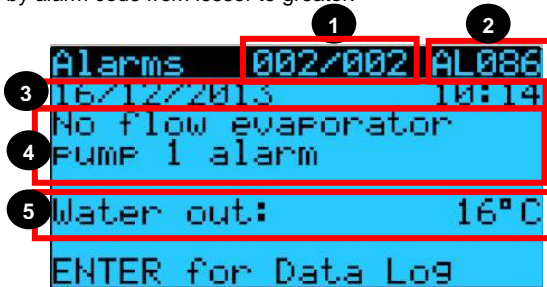

Each alarm contains the information needed to understand the cause of the alarm.

The information available in the screen is shown below:

1. Alarm number/total alarms;
2. Unique alarm code;
3. Alarm date and time;
4. Long alarm description;
5. Value of the probe linked to the alarm;

In every alarm screen, the alarms log can be displayed by pressing ENTER.

The red LED under the ALARM button can be:

- Off: no active alarm;
- Flashing: there is at least one active alarm and the display shows a screen that is not part of the alarms loop.
- On: there is at least one active alarms and a screen that is part of the alarms loop is displayed.

9.1.2 Alarms log

From the main menu, entering the Alarms Log menu allows access to the following alarms log display screen.



The alarms log memorizes the FLSTDmSCHE operation status when the alarms are triggered. Each log entry is an event that can be displayed from among all of the events available in the memory. The information saved in the alarms screen will also be saved in the alarms log. The maximum number of events that can be saved is 100. Once the limit is reached, the most recent alarm will overwrite the oldest one. The alarms log can be cleared in the HW-SW menu through the E010 parameter or by restoring the pCO to default values.

9.1.3 Reset alarms

The alarms can be reset manually, automatically or automatically with retries:

- Manual reset: when the cause of the alarm has stopped, the buzzer must first be reset using the ALARM button and then the ALARM button pressed a second time for a true reset. At this point, even the specific alarm action is reset and the device can restart.
- Automatic reset: when the alarm condition stops automatically, the buzzer is silenced and the alarm reset.
- Automatic reset with retries: The number of interventions per hour is checked. If that number is less than the set maximum, the alarm is on automatic reset, once the limit is exceeded it becomes manual.

9.2 Alarms table

Code	Description	Reset	Action	Delay
AL001	Probe U1 broken or disconnected	A	Unit OFF and compressors in controlled shutdown	10s
AL002	Probe U2 broken or disconnected	A	Unit OFF and compressors in controlled shutdown	10s
AL003	Probe U3 broken or disconnected	A	None	10s
AL004	Probe U4 broken or disconnected	A	None	10s
AL005	Probe U5 broken or disconnected	A	None	10s
AL006	Probe U6 broken or disconnected	A	None	10s
AL007	Clock card broken	A	None	No
AL008	Memory expansion damaged	A	None	No
AL009	Remote alarm	M	Unit OFF and compressors OFF immediately	No
AL010	Envelope data error: check data entered	M	Unit OFF and compressors in controlled shutdown	No
AL011	Custom general alarm 1	M	Unit OFF and compressors in controlled shutdown	No
AL012	Suction press.circ.1 S1 EVD probe broken or disconnected	A	Compressor 1 OFF immediately	No
AL013	Suction temp.circ.1 S2 EVD probe broken or disconnected	A	Compressor 1 OFF in controlled shutdown	No
AL014	Discharge press.circ.1 S3 EVD probe broken or disconnected	A	Compressor 1 OFF in controlled shutdown	No
AL015	Discharge temp.circ.1 S4 EVD probe broken or disconnected	A	Compressor 1 OFF immediately	No
AL016	Low SH alarm circ.1	M	Compressor 1 OFF immediately	Parameter
AL017	LOP alarm circuit 1	A	Compressor 1 OFF in controlled shutdown	Parameter
AL018	MOP alarm circuit 1	A	Compressor 1 OFF in controlled shutdown	Parameter
AL019	Motor valve A alarm circuit 1	M	Compressor 1 OFF immediately	No
AL020	Low suction temp. alarm circuit 1	A	Compressor 1 OFF in controlled shutdown	Parameter
AL021	High condensing temp. alarm circuit 1	A	Compressor 1 OFF in controlled shutdown	Parameter
AL022	Battery alarm circuit 1	A	None	No
AL023	EEPROM EVD circuit 1 alarm	A	None	No
AL024	Incomplete valve closing alarm circ.1	A	Compressor 1 OFF in controlled shutdown	No
AL025	Emergency valve closing alarm circ.1	A	Compressor 1 OFF in controlled shutdown	No
AL026	EVD circ.1 FW not OK	A	Compressor 1 OFF in controlled shutdown	No
AL027	EVD circ.1 configuration error	A	Compressor 1 OFF immediately	No

Code	Description	Reset	Action	Delay
AL028	EVD circ.1 offline	A	Compressor 1 OFF immediately	No
AL029	High pressure ratio circuit 1 alarm	A	Compressor 1 OFF in controlled shutdown	Parameter
AL030	High discharge press. circuit 1 alarm	M	Compressor 1 OFF in controlled shutdown	Parameter
AL031	High motor current compressor 1 alarm	A	Compressor 1 OFF in controlled shutdown	Parameter
AL032	High suction pressure circuit 1 alarm	A	Compressor 1 OFF in controlled shutdown	Start/Run parameter
AL033	Low pressure ratio circuit 1 alarm	A	Compressor 1 OFF in controlled shutdown	Start/Run parameter
AL034	Low delta pressure circuit 1 alarm	A	Compressor 1 OFF in controlled shutdown	Start/Run parameter
AL035	High discharge temp. circuit 1 alarm	A	Compressor 1 OFF immediately	Start/Run parameter
AL036	Low discharge pressure circuit 1 alarm	A	Compressor 1 OFF in controlled shutdown	Start/Run parameter
AL037	Low suction pressure circuit 1 alarm	R	Compressor 1 OFF in controlled shutdown	Start/Run parameter
AL038	Overload compressor 1 alarm	M	Compressor 1 OFF immediately	No
AL039	High pressure from pressure switch circuit 1	M	Compressor 1 OFF immediately	No
AL040	Low pressure from pressure switch circuit 1	M	Compressor 1 OFF immediately	Start/Run parameter
AL041	Maintenance request compressor 1	A	None	Parameter
AL042	Oil level circuit 1 alarm	M	Compressor 1 OFF immediately	Start/Run parameter
AL043	Pumpdown end for max time circuit 1	A	None	No
AL044	Custom circ.1 alarm 2	M	Compressor 1 OFF immediately	No
AL045	Suction press.circ.2 S1 EVD probe broken or disconnected	A	Compressor 2 OFF immediately	No
AL046	Suction temp.circ.2 S2 EVD probe broken or disconnected	A	Compressor 2 OFF in controlled shutdown	No
AL047	Discharge press.circ.2 S3 EVD probe broken or disconnected	A	Compressor 2 OFF in controlled shutdown	No
AL048	Discharge temp.circ.2 S4 EVD probe broken or disconnected	A	Compressor 2 OFF immediately	No
AL049	Low SH alarm circ.2	M	Compressor 2 OFF immediately	Parameter
AL050	LOP alarm circuit 2	A	Compressor 2 OFF in controlled shutdown	Parameter
AL051	MOP alarm circuit 2	A	Compressor 2 OFF in controlled shutdown	Parameter
AL052	Motor valve A alarm circuit 2	M	Compressor 2 OFF immediately	No
AL053	Low suction temp. alarm circuit 2	A	Compressor 2 OFF in controlled shutdown	Parameter
AL054	High condensing temp. alarm circuit 2	A	Compressor 2 OFF in controlled shutdown	Parameter
AL055	Battery alarm circuit 2	A	None	No
AL056	EEPROM EVD circuit 2 alarm	A	None	No
AL057	Incomplete valve closing alarm circ.2	A	Compressor 2 OFF in controlled shutdown	No
AL058	Emergency valve closing alarm circ.2	A	Compressor 2 OFF in controlled shutdown	No
AL059	EVD circ.2 FW not OK	A	Compressor 2 OFF in controlled shutdown	No
AL060	EVD circ.2 configuration error	A	Compressor 2 OFF immediately	No
AL061	EVD circ.2 offline	A	Compressor 2 OFF immediately	No
AL062	High pressure ratio circuit 2 alarm	A	Compressor 2 OFF in controlled shutdown	Parameter
AL063	High discharge press. circuit 2 alarm	M	Compressor 2 OFF in controlled shutdown	Parameter
AL064	High motor current compressor 2 alarm	A	Compressor 2 OFF in controlled shutdown	Parameter
AL065	High suction pressure circuit 2 alarm	A	Compressor 2 OFF in controlled shutdown	Start/Run parameter
AL066	Low pressure ratio circuit 2 alarm	A	Compressor 2 OFF in controlled shutdown	Start/Run parameter
AL067	Low delta pressure circuit 2 alarm	A	Compressor 2 OFF in controlled shutdown	Start/Run parameter
AL068	High discharge temp. circuit 2 alarm	A	Compressor 2 OFF immediately	Start/Run parameter
AL069	Low discharge pressure circuit 2 alarm	A	Compressor 2 OFF in controlled shutdown	Start/Run parameter
AL070	Low suction pressure circuit 2 alarm	R	Compressor 2 OFF in controlled shutdown	Start/Run parameter
AL071	Overload compressor 2 alarm	M	Compressor 2 OFF immediately	No
AL072	High pressure from pressure switch circuit 2	M	Compressor 2 OFF immediately	No
AL073	Low pressure from pressure switch circuit 2	M	Compressor 2 OFF immediately	Start/Run parameter
AL074	Maintenance request compressor 2	A	None	Parameter
AL075	Oil level circuit 2 alarm	M	Compressor 2 OFF immediately	Start/Run parameter
AL076	Pumpdown end for max time circuit 2	A	None	No
AL077	Custom circ.2 alarm 2	M	Compressor 2 OFF immediately	No
AL078	Antifreeze alarm circuit 1	M	Compressor 1 OFF immediately	Parameter
AL079	Antifreeze alarm circuit 2	M	Compressor 2 OFF immediately	Parameter
AL080	Custom unit alarm 3	A	Unit OFF and compressors in controlled shutdown	No
AL081	Maintenance request evaporator pump 1	A	None	Parameter
AL082	Maintenance request evaporator pump 2	A	None	Parameter
AL083	Maintenance request condenser 1	A	None	Parameter
AL084	Maintenance request condenser 2	A	None	Parameter
AL085	Evaporator pumps alarm	M	Unit OFF and compressors OFF immediately	No
AL086	No flow evaporator pump 1 alarm	M	Unit OFF and compressors OFF immediately	Start/Run parameter
AL087	No flow evaporator pump 2 alarm	M	Unit OFF and compressors OFF immediately	Start/Run parameter
AL088	Overload evaporator pump 1 alarm	A ⁽¹⁾	None	No
AL089	Overload evaporator pump 2 alarm	A ⁽¹⁾	None	No
AL090	Condenser pumps alarm	M	Unit OFF and compressors OFF immediately	No
AL091	No flow condenser pump 1 alarm	M	Unit OFF and compressors OFF immediately	Start/Run parameter
AL092	No flow condenser pump 2 alarm	M	Unit OFF and compressors OFF immediately	Start/Run parameter
AL093	Overload condenser pump 1 alarm	A ⁽¹⁾	None	No
AL094	Overload condenser pump 2 alarm	A ⁽¹⁾	None	No
AL095	Overload condenser fan 1 alarm	A	None	No
AL096	Overload condenser fan 2 alarm	A	None	No
AL097	This is a beta version Update with official version	M	Unit OFF and compressors OFF immediately	30 days
AL098	Custom unit alarm 1	M	Unit OFF and compressors in controlled shutdown	No
AL099	Custom unit alarm 2	M	Unit OFF and compressors in controlled shutdown	No
AL100	Probe U1 broken or disconnected	A	Unit OFF and compressors in controlled shutdown	10s
AL101	Probe U2 broken or disconnected	A	Unit OFF and compressors in controlled shutdown	10s
AL102	Probe U3 broken or disconnected	A	None	10s
AL103	Probe U4 broken or disconnected	A	None	10s
AL104	Probe U5 broken or disconnected	A	None	10s
AL105	Probe U6 broken or disconnected	A	None	10s
AL106	Clock card broken	A	None	No
AL107	Memory expansion damaged	A	None	No
AL108	Slave Offline	A	Compressor 3,4 OFF in controlled shutdown	20s
AL109	Custom general alarm 2	A	Unit OFF and compressors in controlled shutdown	No
AL110	Custom general alarm 3	M	Unit OFF and compressors in controlled shutdown	No

Code	Description	Reset	Action	Delay
AL111	Suction press.circ.3 S1 EVD probe broken or disconnected	A	Compressor 3 OFF immediately	No
AL112	Suction temp.circ.3 S2 EVD probe broken or disconnected	A	Compressor 3 OFF in controlled shutdown	No
AL113	Discharge press.circ.3 S3 EVD probe broken or disconnected	A	Compressor 3 OFF in controlled shutdown	No
AL114	Discharge temp.circ.3 S4 EVD probe broken or disconnected	A	Compressor 3 OFF immediately	No
AL115	Low SH alarm circ.3	M	Compressor 3 OFF immediately	Parameter
AL116	LOP alarm circuit 3	A	Compressor 3 OFF in controlled shutdown	Parameter
AL117	MOP alarm circuit 3	A	Compressor 3 OFF in controlled shutdown	Parameter
AL118	Motor valve A alarm circuit 3	M	Compressor 3 OFF immediately	No
AL119	Low suction temp. alarm circuit 3	A	Compressor 3 OFF in controlled shutdown	Parameter
AL120	High condensing temp. alarm circuit 3	A	Compressor 3 OFF in controlled shutdown	Parameter
AL121	Battery alarm circuit 3	A	None	No
AL122	EEPROM EVD circuit 3 alarm	A	None	No
AL123	Incomplete valve closing alarm circ.3	A	Compressor 3 OFF in controlled shutdown	No
AL124	Emergency valve closing alarm circ.3	A	Compressor 3 OFF in controlled shutdown	No
AL125	EVD circ.3 FW not OK	A	Compressor 3 OFF in controlled shutdown	No
AL126	EVD circ.3 configuration error	A	Compressor 3 OFF immediately	No
AL127	EVD circ.3 offline	A	Compressor 3 OFF immediately	No
AL128	High pressure ratio circuit 3 alarm	A	Compressor 3 OFF in controlled shutdown	Parameter
AL129	High discharge press. circuit 3 alarm	M	Compressor 3 OFF in controlled shutdown	Parameter
AL130	High motor current compressor 3 alarm	A	Compressor 3 OFF in controlled shutdown	Parameter
AL131	High suction pressure circuit 3 alarm	A	Compressor 3 OFF in controlled shutdown	Start/Run parameter
A132	Low pressure ratio circuit 3 alarm	A	Compressor 3 OFF in controlled shutdown	Start/Run parameter
A133	Low delta pressure circuit 3 alarm	A	Compressor 3 OFF in controlled shutdown	Start/Run parameter
A134	High discharge temp. circuit 3 alarm	A	Compressor 3 OFF immediately	Start/Run parameter
A135	Low discharge pressure circuit 3 alarm	A	Compressor 3 OFF in controlled shutdown	Start/Run parameter
A136	Low suction pressure circuit 3 alarm	R	Compressor 3 OFF in controlled shutdown	Start/Run parameter
A137	Overload compressor 3 alarm	M	Compressor 3 OFF immediately	No
A138	High pressure from pressure switch circuit 3	M	Compressor 3 OFF immediately	No
A139	Low pressure from pressure switch circuit 3	M	Compressor 3 OFF immediately	Start/Run parameter
A140	Maintenance request compressor 3	A	None	Parameter
A141	Oil level circuit 3 alarm	M	Compressor 3 OFF immediately	Start/Run parameter
A142	Pumpdown end for max time circuit 3	A	None	No
A143	Custom circ.3 alarm 2	M	Compressor 3 OFF immediately	No
A144	Suction press.circ.4 S1 EVD probe broken or disconnected	A	Compressor 4 OFF immediately	No
A145	Suction temp.circ.4 S2 EVD probe broken or disconnected	A	Compressor 4 OFF in controlled shutdown	No
A146	Discharge press.circ.4 S3 EVD probe broken or disconnected	A	Compressor 4 OFF in controlled shutdown	No
A147	Discharge temp.circ.4 S4 EVD probe broken or disconnected	A	Compressor 4 OFF immediately	No
A148	Low SH alarm circ.4	M	Compressor 4 OFF immediately	Parameter
A149	LOP alarm circuit 4	A	Compressor 4 OFF in controlled shutdown	Parameter
A150	MOP alarm circuit 4	A	Compressor 4 OFF in controlled shutdown	Parameter
A151	Motor valve A alarm circuit 4	M	Compressor 4 OFF immediately	No
A152	Low suction temp. alarm circuit 4	A	Compressor 4 OFF in controlled shutdown	Parameter
A153	High condensing temp. alarm circuit 4	A	Compressor 4 OFF in controlled shutdown	Parameter
A154	Battery alarm circuit 4	A	None	No
A155	EEPROM EVD circuit 4 alarm	A	None	No
A156	Incomplete valve closing alarm circ.4	A	Compressor 4 OFF in controlled shutdown	No
A157	Emergency valve closing alarm circ.4	A	Compressor 4 OFF in controlled shutdown	No
A158	EVD circ.4 FW not OK	A	Compressor 4 OFF in controlled shutdown	No
A159	EVD circ.4 configuration error	A	Compressor 4 OFF immediately	No
A160	EVD circ.4 offline	A	Compressor 4 OFF immediately	No
A161	High pressure ratio circuit 4 alarm	A	Compressor 4 OFF in controlled shutdown	Parameter
A162	High discharge press. circuit 4 alarm	M	Compressor 4 OFF in controlled shutdown	Parameter
A163	High motor current compressor 4 alarm	A	Compressor 4 OFF in controlled shutdown	Parameter
A164	High suction pressure circuit 4 alarm	A	Compressor 4 OFF in controlled shutdown	Start/Run parameter
A165	Low pressure ratio circuit 4 alarm	A	Compressor 4 OFF in controlled shutdown	Start/Run parameter
A166	Low delta pressure circuit 4 alarm	A	Compressor 4 OFF in controlled shutdown	Start/Run parameter
A167	High discharge temp. circuit 4 alarm	A	Compressor 4 OFF immediately	Start/Run parameter
A168	Low discharge pressure circuit 4 alarm	A	Compressor 4 OFF in controlled shutdown	Start/Run parameter
A169	Low suction pressure circuit 4 alarm	R	Compressor 4 OFF in controlled shutdown	Start/Run parameter
A170	Overload compressor 4 alarm	M	Compressor 4 OFF immediately	No
A171	High pressure from pressure switch circuit 4	M	Compressor 4 OFF immediately	No
A172	Low pressure from pressure switch circuit 4	M	Compressor 4 OFF immediately	Start/Run parameter
A173	Maintenance request compressor 4	A	None	Parameter
A174	Oil level circuit 4 alarm	M	Compressor 4 OFF immediately	Start/Run parameter
A175	Pumpdown end for max time circuit 4	A	None	No
A176	Custom circ.4 alarm 2	M	Compressor 4 OFF immediately	No
A177	Antifreeze alarm circuit 3	M	Compressor 3 OFF immediately	Parameter
A178	Antifreeze alarm circuit 4	M	Compressor 4 OFF immediately	Parameter
A179	Overload condenser fan 3 alarm	A	None	No
A180	Overload condenser fan 4 alarm	A	None	No
A181	Maintenance request condenser 3	A	None	Parameter
A182	Maintenance request condenser 4	A	None	Parameter
A187	Custom unit alarm 3	M	None	No
A188	Maintenance request fan 2 circuit 1	A	None	Parameter
A189	Maintenance request fan 3 circuit 1	A	None	Parameter
A190	Maintenance request fan 2 circuit 2	A	None	Parameter
A191	Maintenance request fan 3 circuit 2	A	None	Parameter
A192	Maintenance request fan 2 circuit 3	A	None	Parameter
A193	Maintenance request fan 3 circuit 3	A	None	Parameter
A194	Maintenance request fan 2 circuit 4	A	None	Parameter
A195	Maintenance request fan 3 circuit 4	A	None	Parameter
A196	Inverter comp.1 alarm	A	Compressor 1 OFF immediately	No
A197	Inverter comp.2 alarm	A	Compressor 2 OFF immediately	No

Code	Description	Reset	Action	Delay
A198	Inverter comp.3 alarm	A	Compressor 3 OFF immediately	No
A199	Inverter comp.4 alarm	A	Compressor 4 OFF immediately	No
A200	Inverter comp.1 alarm by MBM	A	Compressor 1 OFF immediately	No
A201	Inverter comp.2 alarm by MBM	A	Compressor 2 OFF immediately	No
A202	Inverter comp.1 offline	A	None	No
A203	Inverter comp.2 offline	A	None	No
A204	Free cooling ineffective, outlet water temperature increasing.	M	Free cooling off immediately	No
A205	Outlet water high temperature alarm	A	None	No

⁽¹⁾ In case of single evaporator/condenser pump, also the "alarm evaporator/condenser pumps " is activated which has a manual reset. In case of double evaporator/condenser pump, the latter is activated only when both "overload pump alarm" are simultaneously active.

Reset:

A: automatic reset

M: manual reset

R: Automatic reset with retries

CAREL INDUSTRIES reserves the right to make changes or modifications to its products without prior notice.

All trademarks hereby referenced are the property of their respective owners.

CAREL is a registered trademark of CAREL INDUSTRIES Hqs in Italy and/or other countries.

© CAREL INDUSTRIES Hqs 2014 all rights reserved

CAREL

CAREL INDUSTRIES S.p.a.

Via dell'Industria, 11 - 35020 Brugine - Padova (Italy)

Tel. (+39) 049.9716611 Fax (+39) 049.9716600

<http://www.carel.com> - e-mail: carel@carel.com

