

SKP Series

SKP15...U.. Gas Valve Actuator with Safety Shutoff Function



ISO 9001 and 14000
REGISTERED FIRM



Only when assembled to Series VG...U Gas valves

Description

SKP15... electro-hydraulic actuators combine with VG... series gas valves to provide safety shut-off control for industrial and commercial burner applications.

The compact SKP15... actuator opens slowly and closes immediately when power is interrupted. The modular design allows the SKP15... to be used in combination with all VG... series gas valves bodies from 1/2-inch to 6 inches in size. The actuator easily mounts on the square flange of any VG... valve with four pre-mounted screws. A visible position indicator on the front of the actuator displays the entire stroke of the valve. A light indicates when the actuator is powered.

Features

- UL listed, FM approved, CSA certified for USA and Canada, and ISO 9001 certified. European, Australian and Japanese approved versions available.
- Proof of Closure with Over Travel (POC) versions.
- Optional NEMA 4 protection.
- Visual position indication.
- "Power on" indication light
- Quick connect wiring terminals
- Optional adjustable auxiliary switch available.
- Modular design with 360° actuator rotation for easy field wiring and installation.
- Low, 13.5 VA power consumption.

Application

SKP15... series actuators are combined with 1/2-inch to 6-inch VG... series gas valve bodies. VG... series gas valves must be ordered separately (See *VG...U... Technical Instructions*, P/N 155-512P25).

Product Numbers

Table 1.

Product Number ¹	Operating Voltage	Proof of Closure Switch ²	Auxiliary Switch ²	Type of Switch
SKP15.013U1	110 to 120 Vac	–	–	–
SKP15.012U1		X	X	SPDT SPDT
SKP15.011U1		X	–	SPDT
SKP15.013U2	220 to 240 Vac	–	–	–
SKP15.012U2		X	X	SPDT SPDT

Note:

1. European, CE certified models are available (see *data sheet 7643*)
2. Proof of closure and auxiliary switches cannot be field installed.

Accessories

AGA66 Sealing gasket to provide NEMA 3, 3R, and 4 protection (for VGG.../VGD...valves)

Specifications	As safety shut-off valve	UL/429, FM/7400, ANSI Z21.21/CGA6.5 C/I Agency marks apply only for SKPxx.xxxU actuators with VGxxx.xxxU series gas valve bodies.
Agency approvals		
Power supply	Operating voltage	110 to 120 Vac + 10% to -15% 220 to 240 Vac + 10% to -15%
	Operating frequency	50 to 60 Hz ± 6%
	Power consumption	13.5 VA
	Duty cycle	continuous
Operating environment	Ambient operating temperature	5°F to 140°F (–15°C to 60°C)
	Mounting position	Any position except upside down
Physical characteristics	Weight	2.4 lb (1.1 kg)
	Enclosure	NEMA 1, 2, 5, and 12 for indoor use NEMA 3, 3R, and 4 with optional AGA66 gasket
	Dimensions	See Figure 3
	Specification for valve bodies	See <i>gas valve Technical Instructions</i> , P/N 155-512P25
Operating characteristics	Conduit connection	Two 1/2-inch NPSM threaded knock-outs
	Electrical connection	Spring loaded terminals for 14 AWG wires
	Output force	100 lb (450 N)
Auxiliary features	Maximum stroke	1 inch (26 mm)
	Opening time for maximum stroke	Varies with valve size, 14 seconds for max. stroke
	Closing time	<0.8 seconds
Auxiliary features	Proof of closure switch	Non-adjustable
	Setting range of auxiliary switch	40% to 100% of stroke
	Switch rating	6A/250 Vac resistive; 3A/120 Vac pilot duty

Operation

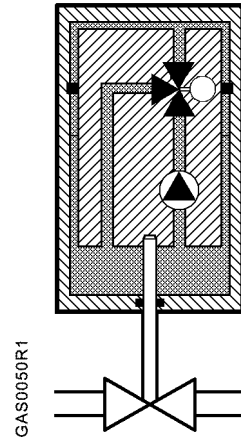

Figure 1. SKP15... Operation.

The electro-hydraulic actuator consists of a cylinder filled with oil, a piston containing an electric oscillating pump, and a relief system. When power is supplied to the actuator, the relief system closes, and the pump moves oil from the reservoir into the pressure chamber. This action causes the piston to move downward in the cylinder, opening the gas valve. When power to the actuator is interrupted, the relief system opens and the gas valve closes in less than 0.8 seconds.

A position indicator, visible through the transparent portion of the terminal cover, shows the entire stroke range of the actuator. A light, which is visible through the lower left transparent portion of the terminal cover, indicates when the actuator receives power. An optional, non-adjustable SPDT proof of closure over travel switch signals the closed position after the gas valve has closed. An optional SPDT auxiliary switch is adjustable between 40% and 100% of the stroke. The adjustment screw and scale are located on the right side in the terminal box, and are visible through the transparent portion of the terminal cover.

Installation



WARNING:

- Personal injury or loss of life may occur if procedures are not followed as specified.
 - All installations must be performed by qualified personnel only.
 - Do not pull the actuator shaft.
 - The AGA66 gasket must be installed between the actuator and the gas valve body to provide NEMA 3, 3R, and 4 protection rating for VGG... and VGD... valves.
- The SKP15... actuator is directly coupled to the VG... series valve body by four pre-mounted 4 mm Allen key screws.
 - The square mounting flange can be rotated in steps of 90° to provide four different mounting positions. The SKP15... actuator can be mounted in any position except upside down.
 - The actuator can be mounted or replaced while the valve body is under pressure.
 - The SKP15... actuator has two knock-outs for the installation of 1/2"-14 NPSM conduit connections.
 - When conduit routing is connected, flexible conduit must be used.
 - Liquid tight conduit must be used in combination with AGA66 to provide NEMA 3, 3R, and 4 protection.
 - The terminal marked GND, located above the wiring terminals, must be connected to the electrical ground.

Installation, Continued

NOTE: Wiring must meet all relevant electrical codes.

Wiring and Switch Adjustment

(See *Terminal
Designations*)

- The actuator is equipped with spring-loaded terminals for 14 AWG wires.
- The actuator has two line and two neutral terminals.
- Insert one wire into the opening of the terminal while pressing the lever downward with a screwdriver or hard object. Make sure that all strands insert into the opening.
- Adjust the auxiliary switch (if provided) according to the wiring diagram on the label below the terminals (see Figure 2). The adjustment screw and scale are located on the right side of the terminal box, and are visible through the transparent portion of the terminal cover.

- NOTES:**
1. The auxiliary switch is adjustable between 40% and 100% of the stroke. The factory setting is at 40%.
 2. The auxiliary switch must not be used for proof of closure detection or other safety interlock functions.
 3. The Proof of Closure Switch is non-adjustable.

Service

There are no serviceable parts on the SKP15... series actuators. If inoperative, replace the entire actuator. Tag wires before servicing.

Terminal Designations

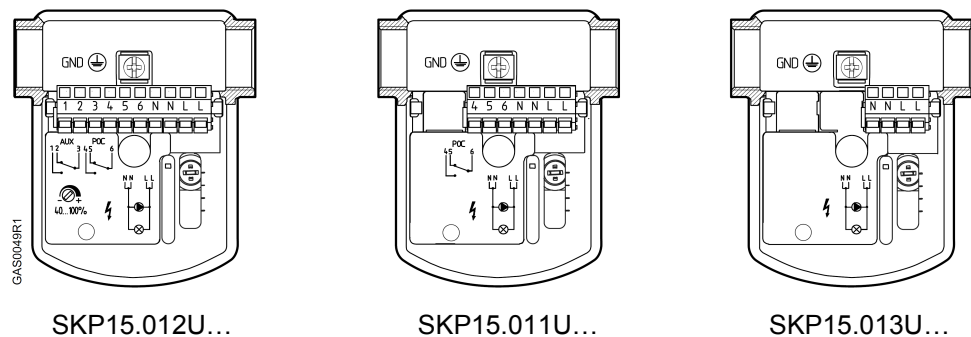

Figure 2. Terminal Designations.

Dimensions

(Dimensions in inches;
 millimeters in
 brackets)

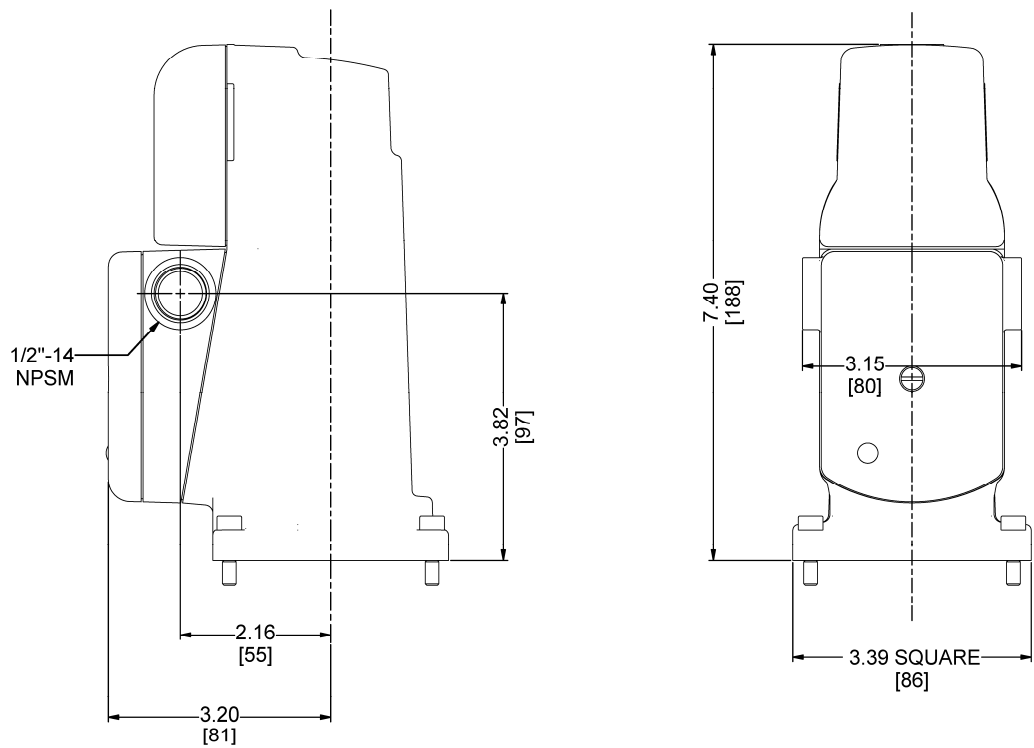

Figure 3. SKP15...U.. Dimensions.

Information in this publication is based on current specifications. The company reserves the right to make changes in specifications and models as design improvements are introduced. Other product or company names mentioned herein may be the trademarks of their respective owners.
 © 2005 Siemens Building Technologies, Inc.

SCC Inc.
 1250 Lunt Avenue
 Elk Grove Village, IL 60007
 U.S.A.

WYMBBS INC
 Hev-e-Oil Burner Distributors
 2395 WASHINGTON AVENUE - BRONX, NY10458
 (718) 295-3500 FAX (718) 295-4526
 WWW.WYMBBS.COM
 EST. 1938

Your feedback is important to us. If you have comments about this document, please send them to techsupport@SCCcombustion.com

Document No. 155-751
 Country of Origin: US
Page 5