

SQM5...

Reversing Actuators

ISO 9001
REGISTERED FIRM

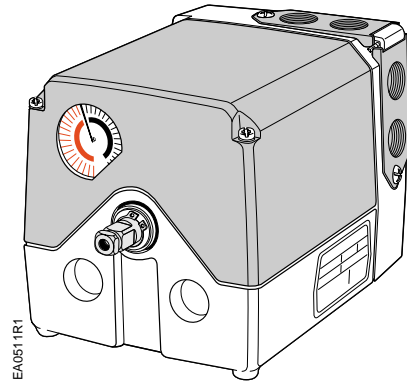

Description

SQM5... reversing actuators are used for the positioning of flow control valves, butterfly valves, dampers, or any application requiring rotary motion. The SQM5... actuators accommodate control input signals of 4-20 mA, 0-135 Ω , 0-10 Vdc, 0-20 mA, position proportional and floating control. The available output signals include 4-20 mA, 0-135 Ω , 0-10 Vdc, 0-20 mA, and 0-1000 Ω . SQM5... actuators are available with up to eight internal, easily accessible and adjustable auxiliary switches.

A selection of exchangeable circuit boards provide a variety of functions including auto/manual selector switch, manual forward/reverse toggle switch, zero and span adjustment, parallel or master/slave operation, split range control, input signal override, and selectable electronic linearization.

The SQM5... is engineered for precision. It is particularly well suited to applications requiring a high degree of modulating accuracy and repeatability. Drive shaft play is limited to 0.3° with a modulating accuracy of 250 repositions through 90° of travel.

The SQM5... actuator may be mounted in any position. A selection of mounting brackets and shafts provide installation flexibility and allow for the simple replacement of most competitive actuators.

Features

- Modulating accuracy of 250 repositions through 90°
- Two limit switches, plus up to six internal auxiliary switches
- Full closed “economy position” switch
- Drive shaft and cam drum disengagement clutches
- Auto/manual switch, manual control forward/reverse toggle switch
- UL, CSA and CE approved 24, 110 and 220 Vac versions
- Field reversible clockwise (cw) or counterclockwise (ccw) operation
- Various torque ratings and running times available
- Selection of field exchangeable one and two ended shafts
- Mounting brackets to replace competitive actuators

Features, Continued

- Connections for both base and face mounting
- Low hysteresis actuator and potentiometer gearing
- Externally visible position indication
- Selection of input and output signals
- Zero and span adjustment
- Field exchangeable circuit boards and potentiometers
- Electronic damper linearization function
- Split range and selectable parallel or master/slave operation
- Adjustable input signal override function

Table Of Contents

Application	Page 3
Product Numbers	
Product numbers for pre-assembled UL/CSA/CE-approved actuators, Table 1	Page 3
Product numbers for accessories, Table 2	Page 4
SQM5... Product Number Identification Legend	Page 5
Installation and Operating Instructions	
Shaft Installation	Page 6
Rotational Direction Verification	Page 7
Actuator Mounting	Page 7
Switch Adjustment	Page 7
Shaft Adjustment	Page 8
Cam Drum Adjustment	Page 8
Wiring	
Electrical Connection	Page 8
Grounding	Page 8
Wiring Connections	
AGA56.1... circuit boards	Page 8
AGA56.41/42/43... circuit boards	Page 9
AGA56.9... circuit boards	Page 11
Commissioning	
Power Actuator	Page 12
Modulation Adjustment	Page 12
Zero Adjustment	Page 12
Span Adjustment	Page 12
Position Indicating Dial Adjustment	Page 13
Cover Installation	Page 13
Features	
SQM5x.xxxxx Z x actuators	Page 14
SQM5x.xxxxx G x actuators	Page 15
SQM5x.xxxxx H x actuators	Page 15
SQM5x.xxxxx K x actuators	Page 15
SQM5x.xxxxx A x actuators	Page 16
Service Guide	
Reversing Rotational Direction	Page 16
Shaft Installation	Page 17
Circuit Board Installation	Page 17
AGA56.41/42/43...	Page 18
AGA56.9A	Page 19
AGA56.1A97	Page 21
Potentiometer Removal/Installation	Page 22
Specification Data	Page 23
Dimensions	Page 26

Application

SQM5... actuators are uniquely suited for both industrial and commercial applications. The high level of accuracy permits precise modulating control of industrial process and process heating applications, often significantly enhancing performance and product quality.

In commercial and industrial burner applications requiring high turndown and reliable ignition, the auxiliary switches can be applied to create separate positions for burner light off and low fire. In dual fuel applications, additional switches can be used to create separate high fire, low fire and light off positions for each fuel. The “economy position” switch is used to drive the actuator to the full closed position when the burner is off.

In all applications, commissioning is simplified. Shaft and switch cam drum disengagement clutches allow for the quick manual alignment of the actuator shaft and switch cams. The forward/reverse toggle switch in combination with the auto/manual selector switch provides direct manual control.

Product Numbers

Table 1. Product Numbers for Pre-assembled UL/CSA/CE-Approved Actuators.

Torque ¹	Running Time ² 90°@ 60 Hz	Input Control Signals ³				Number of switches	Product Number		
		Line Voltage	4-20 mA	0-135 Ω	0-10 Vdc		For SQM5x.xx0xxxx shafts must be ordered separately For shaft selection refer to <i>Table 2</i> .		
lb-in	sec					110 V	220 V	24 V	
90	8	X							
90	8	X	X			2/4	SQM50.260R1G4	SQM50.260R2A	
90	12	X	X			2/4	SQM50.364R1G3		
140	25	X				2/4	SQM50.464R1A3		
140	25	X	X	X	X	2/6	SQM50.480R1Z3 ³		
140	25	X				2/3	SQM50.450R1A		
140	25	X	X			2/4	SQM50.460R1G3		
140	25	X		X		2/4	SQM50.460R1H3		
140	25	X	X	X	X	2/6		SQM50.480R2Z3 ³	
200	25	X	X	X	X	2/6	SQM53.480R1Z3 ³		
200	25	X	X			2/6	SQM53.480R1G3		
200	25	X				2/4	SQM53.460R1A		
310	37	X				2/4	SQM56.560R1A		
310	37	X	X			2/4	SQM56.560R1G4		
310	37	X		X		2/4	SQM56.564R1H4		
400	50	X	X	X	X	2/6	SQM56.680R1Z3 ³		
400	50	X	X			2/6	SQM56.680R1G3		
								SQM50.480R8Z3 ³ SQM50.450R8A SQM50.450R8G3 SQM50.450R8H3	

1. Torque will vary with the selection of the shaft. See *Specifications*.
2. Running time for 135° → multiply by 1.5 For 50 Hz → multiply by 1.2
3. SQM5x.xxxxxZx models also accept a 0-20 mA input signal.

Table 2. Product Numbers for Accessories.

Electronic circuit boards

AGA56.1A97	24-250 Vac	(A) board for SQM5x.xxxxxAx
AGA56.9A87	24 Vac	(Z) board for SQM5x.xxxxxZx
AGA56.9A17	120 Vac	(Z) board for SQM5x.xxxxxZx
AGA56.9A27	220 Vac	(Z) board for SQM5x.xxxxxZx
AGA56.41A87	24 Vac	(G) board for SQM5x.xxxxxGx
AGA56.41A17	110 Vac	(G) board for SQM5x.xxxxxGx
AGA56.41A27	220 Vac	(G) board for SQM5x.xxxxxGx
AGA56.42A17	110 Vac	(H) board for SQM5x.xxxxxHx
AGA56.42A27	220 Vac	(H) board for SQM5x.xxxxxHx
AGA56.42A87	24 Vac	(H) board for SQM5x.xxxxxHx
AGA56.43A17	110 Vac	(K) board for SQM5x.xxxxxKx
AGA56.43A27	220 Vac	(K) board for SQM5x.xxxxxKx
AGA56.43A87	24 Vac	(K) board for SQM5x.xxxxxKx

See Product Number Identification Legend, *Figure 1*.

Mounting Brackets & Adapters

AGA57.3	for replacement of Honeywell MOD III, IV actuators
AGA57.4	for replacement of Honeywell M640/740/940 and Barber Colman EA20/40/50/60 actuators. Directly adaptable to Eclipse butterfly valves.
ASK33.9	mounting kit for direct attachment to Siemens VKF41... butterfly valve. (Shaft AGA58.1 required)

Shafts

AGA58.1	10 mm round with key. Gear end only
AGA58.2	12 mm round with key. Gear end only
AGA58.3	9 mm square. Two ended
AGA58.4	3/8 inch square. Two ended
AGA58.7	14 mm round with key. Gear end only

For exact shaft sizes, refer to *DIMENSIONS*.

Crank Arm, Push Rods

338 031	Crank arm kit. Includes two crank arms for connecting the AGA58.4 shaft to a Ø 1/2-inch damper shaft with two ball joints. (does not include push rod)
338 041	Ø 5/16" damper push rod, 12 inches long.
338 042	Ø 5/16" damper push rod, 15 inches long.
338 043	Ø 5/16" damper push rod, 18 inches long.
338 044	Ø 5/16" damper push rod, 24 inches long.
338 045	Ø 5/16" damper push rod, 36 inches long.
338 046	Ø 5/16" damper push rod, 48 inches long.

Potentiometers

ASZ12.803	1000Ω, 90°
ASZ12.833	1000Ω, 135°
ASZ22.803	1000/1000Ω double potentiometer, 90°
ASZ22.833	1000/1000Ω double potentiometer, 135°

Additional potentiometer models available. See *Siemens technical data sheet 7921*.

Product Number Identification Legend

For actuator identification only. To select product numbers for ordering, see *Table 1*.

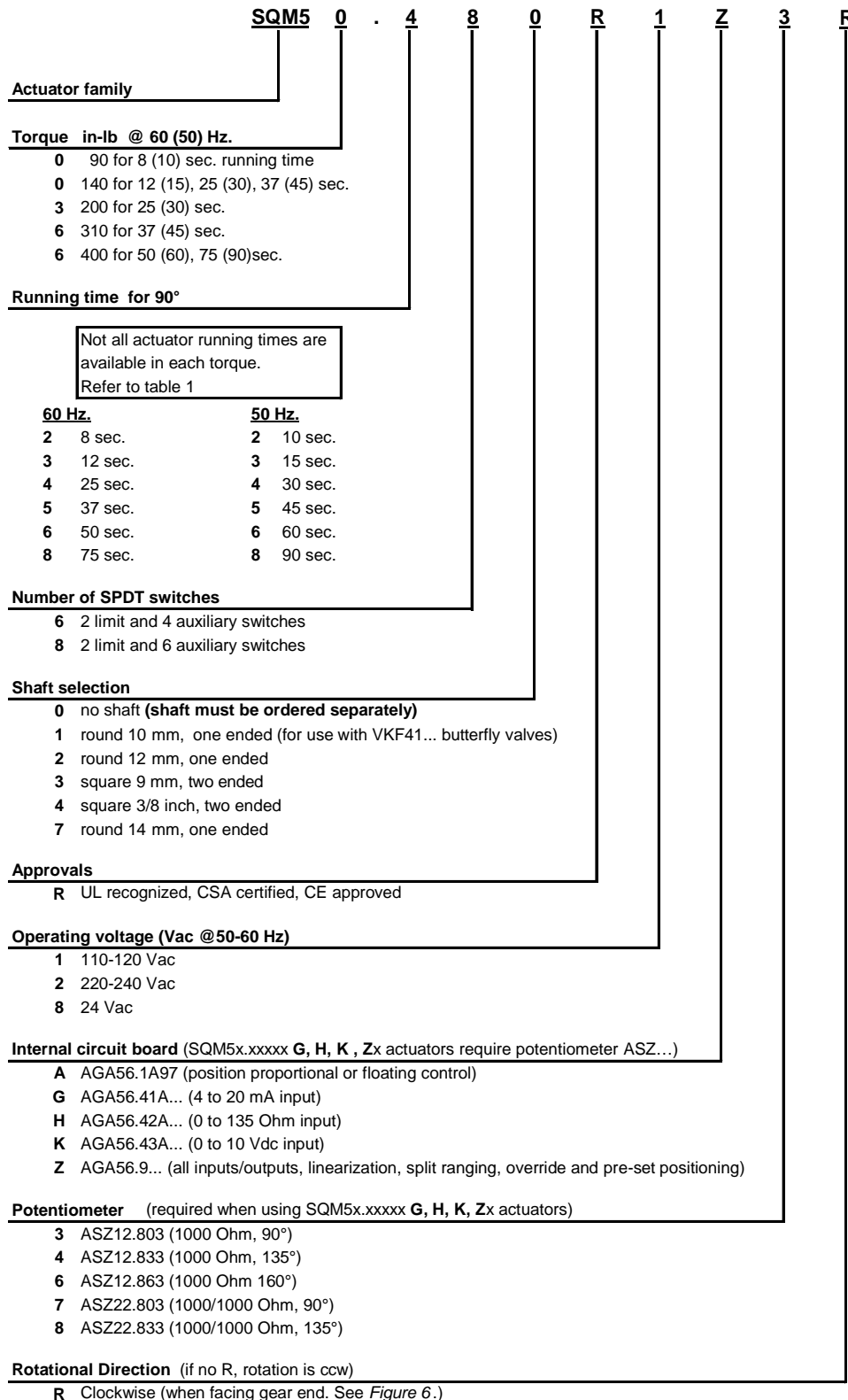

Figure 1. SQM5... Product Number Identification Legend.

Installation and Operation Instructions

SQM5... actuators are generally shipped without the shaft installed. To install the selected shaft:

1. Loosen the two screws on the actuator cover corners. See *Figure 2*.
2. Lift the screws and raise the cover. See *Figure 3*.

Shaft Installation

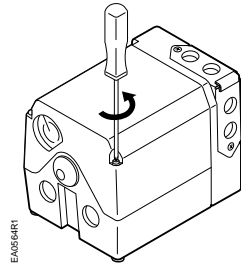

Figure 2.

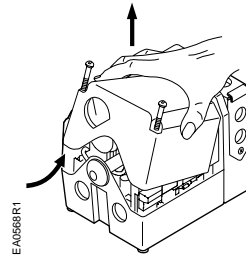

Figure 3.

3. Each shaft is supplied with two washers and a “C” clip. See *Figure 4*. Using spreading pliers, remove the “C” clip and the washers from the shaft.

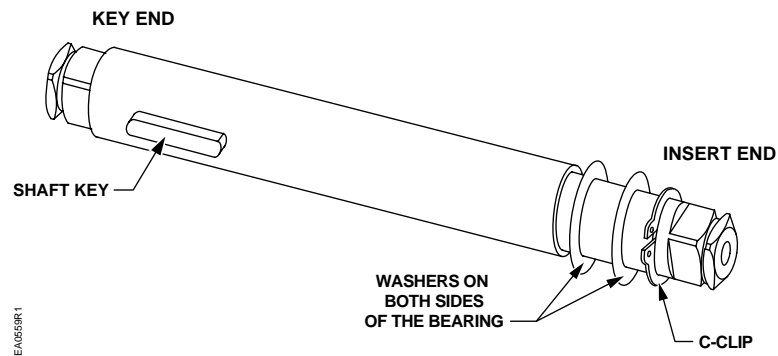

Figure 4.

4. Insert the “insert end” of the shaft into the “gear end” of the actuator.
5. Push the shaft until the “insert end” reaches just short of the brass bushing at the other end of the actuator.
6. Put one of the washers on the insert end of the shaft. See *Figure 5*.

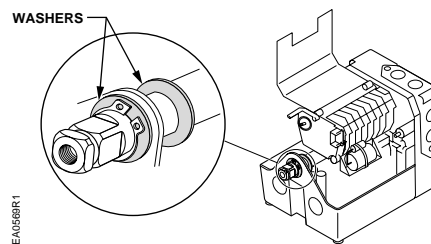

Figure 5.

7. Line up the “shaft key” with the key slot on the “gear end” of the actuator and slide the shaft until the “insert end” is completely through the brass bushing.

8. Place the second washer onto the “insert end” of the shaft. Using spreading pliers, install the “C” clip.

Rotational Direction Verification

Most SQM5... actuators are factory configured for counterclockwise (ccw), minimum to maximum rotation when facing the gear end of the actuator, or clockwise (cw) rotation when facing the other end of the actuator. SQM5.xxxxxxR model numbers, ending with R are factory configured for clockwise (cw) operation. To field reverse the direction of rotation, see *Service Guide*, “Reversing Rotational Direction”.

Actuator Mounting

SQM5... actuators can be mounted in any orientation using the four 1/4"-20 UNC tapped holes located on the bottom corners of the actuator base. Optional base mounting brackets are available. See *Table 2 - Product Numbers for Accessories*. SQM5... actuators can also be face mounted using self tapping screws in combination with the various holes on the face of the actuator gear end.

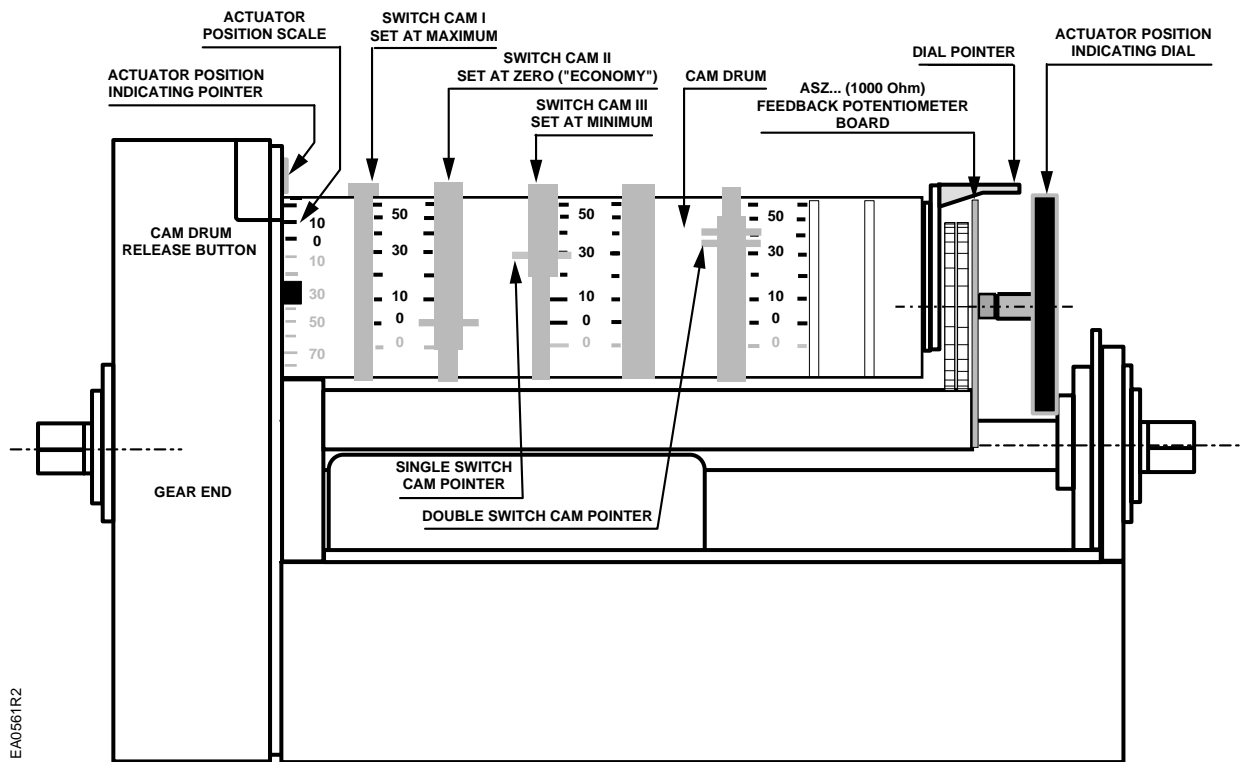

Figure 6. Component Identification on the Cam Drum Side of the SQM5... Actuator.

Switch Adjustment

See *Figure 6*.

All SQM5...actuators are factory wired with Switch I (maximum), Switch II (full closed “economy position”) and Switch III (minimum). The individual switch cams I, II, and III are factory set to 90°, 0° and 30° respectively.

NOTE: The single switch cam pointers are used together with the black scales when configured for counterclockwise (ccw) operation.

The double switch cam pointers are used together with the red scales when configured for clockwise (cw) operation.

The individual switch cams can be adjusted by hand or with the use of the tool attached to the outside of the hinged switch terminal protection lid.

**Switch Adjustment,
continued**

NOTE: SQM5x.xxxxxA actuators may be adjusted between 0° and 160°. SQM5x.xxxxx3 actuators have a 90° potentiometer and the switches must be adjusted only between 0 and 90°. SQM5x.xxxxx4 actuators have a 135° potentiometer and the switches must be adjusted only between 0 and 135°.

Shaft Adjustment

See *Figure 6*.

The actuator shaft can be disengaged by pressing the silver shaft release button located to the right of the auto/manual switch. The shaft can be manually rotated when the button is pressed. Once pressed, the button can be locked by pushing it slightly upwards. After the shaft has been manually aligned, re-engage the shaft by pushing the shaft release button downwards.

Cam Drum Adjustment

See *Figure 6*.

The cam drum must be manually aligned by pressing and holding the black cam drum release button. The cam drum must be rotated until the "0" mark on the cam drum position scale (left scale on the cam drum) is aligned with the gray actuator position indicating pointer.

Wiring

Electrical Connection

SQM5... actuators are equipped with two removable conduit connection plates located on the upper corner of the gear housing. Each plate is provided with two threaded connections for 1/2" NPSM conduit connectors. The use of flexible stranded wire is recommended.

Grounding

To avoid electro-magnetic interference, the SQM5... actuators must be grounded.

The ground terminal is located to the right of the auto/manual switch.

Wiring connections

NOTE: SQM5... actuators require a single source, single phase power supply.

Wiring connections vary depending on which AGA56... circuit board is installed.

AGA56.1... circuit boards.

See *Figures 7 and 8*.

1. Connect line voltage to terminal L. Terminal L must be powered to enable manual operation.
 2. Connect neutral to the double terminal block with the two gray motor wires, located on the left side of the gray switch housing.
 3. Connect line voltage to terminal A to drive the actuator in the opening direction.
 4. Connect line voltage to terminal Z to drive the actuator in the closing direction.
-

Wiring, continued

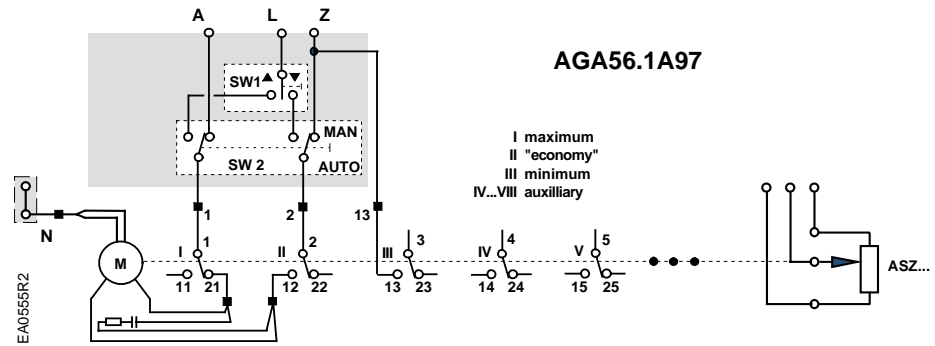

Figure 7. Basic Functional Diagram of AGA56.1...

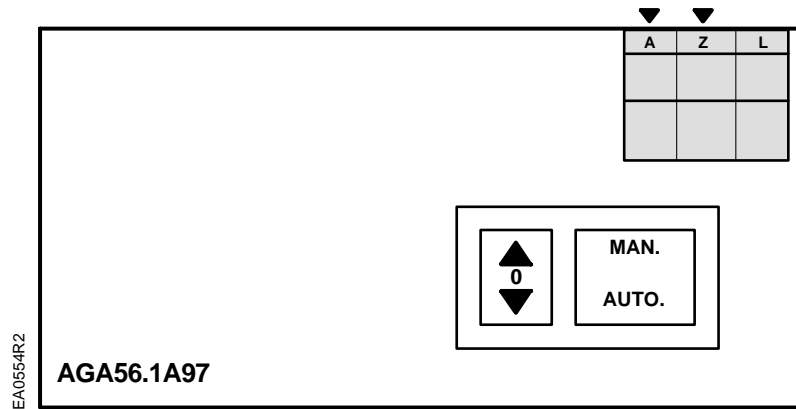

Figure 8. AGA56.1A97 Terminal/Auto-Manual Board.

AGA56.41/42/43... circuit boards.

See Figures 9 and 10.

1. Connect line voltage to terminal L. Terminal L must be powered at all times.
2. Connect neutral to terminal N.
3. Connect ground to the terminal located to the right of the auto/manual switch.
4. For applications where terminals Z, ZL, A and 13 are not used, bridge terminal LR and L. If any terminals Z, ZL, A or 13 are used, terminal LR must not be bridged with terminal L. In addition, terminal LR must never be powered simultaneously with any terminals Z, ZL, A or 13. However, terminal LR must be powered once Z, ZL, A and 13 are no longer powered and modulating operation is required (refer to application guide for typical installation examples).
5. Connect the input control signal wires to the appropriate terminals.

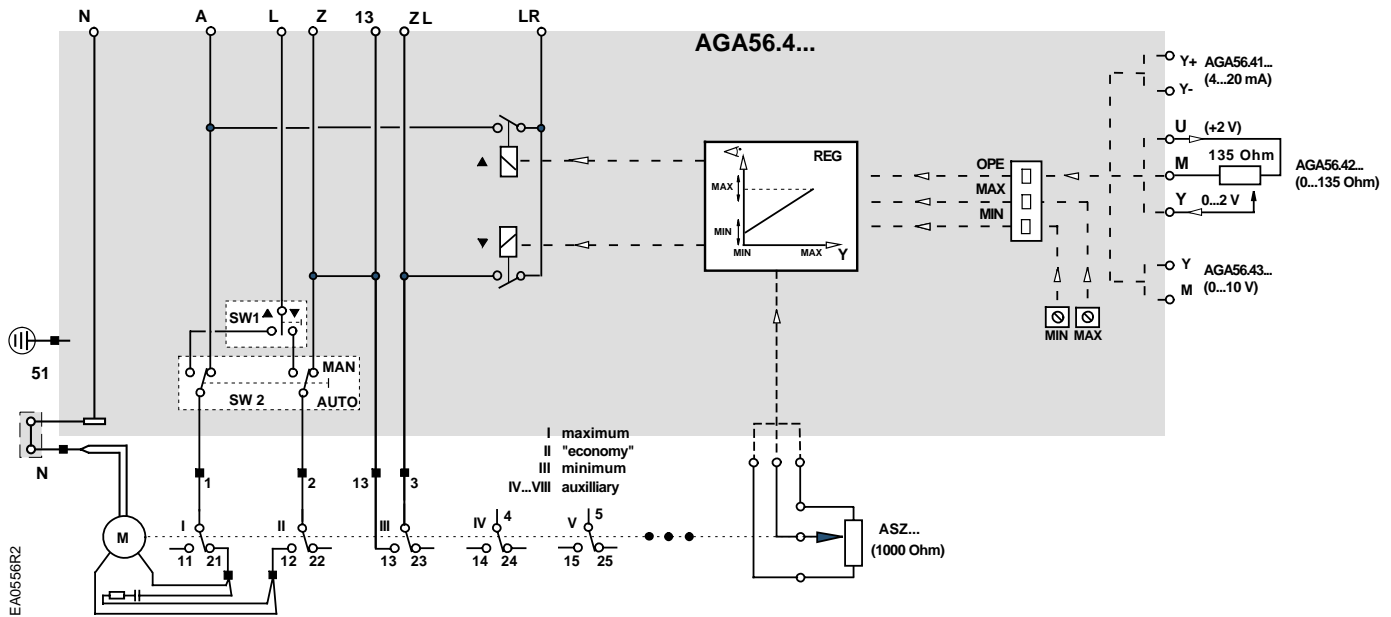

Figure 9. Basic Functional Diagram of AGA56.4...

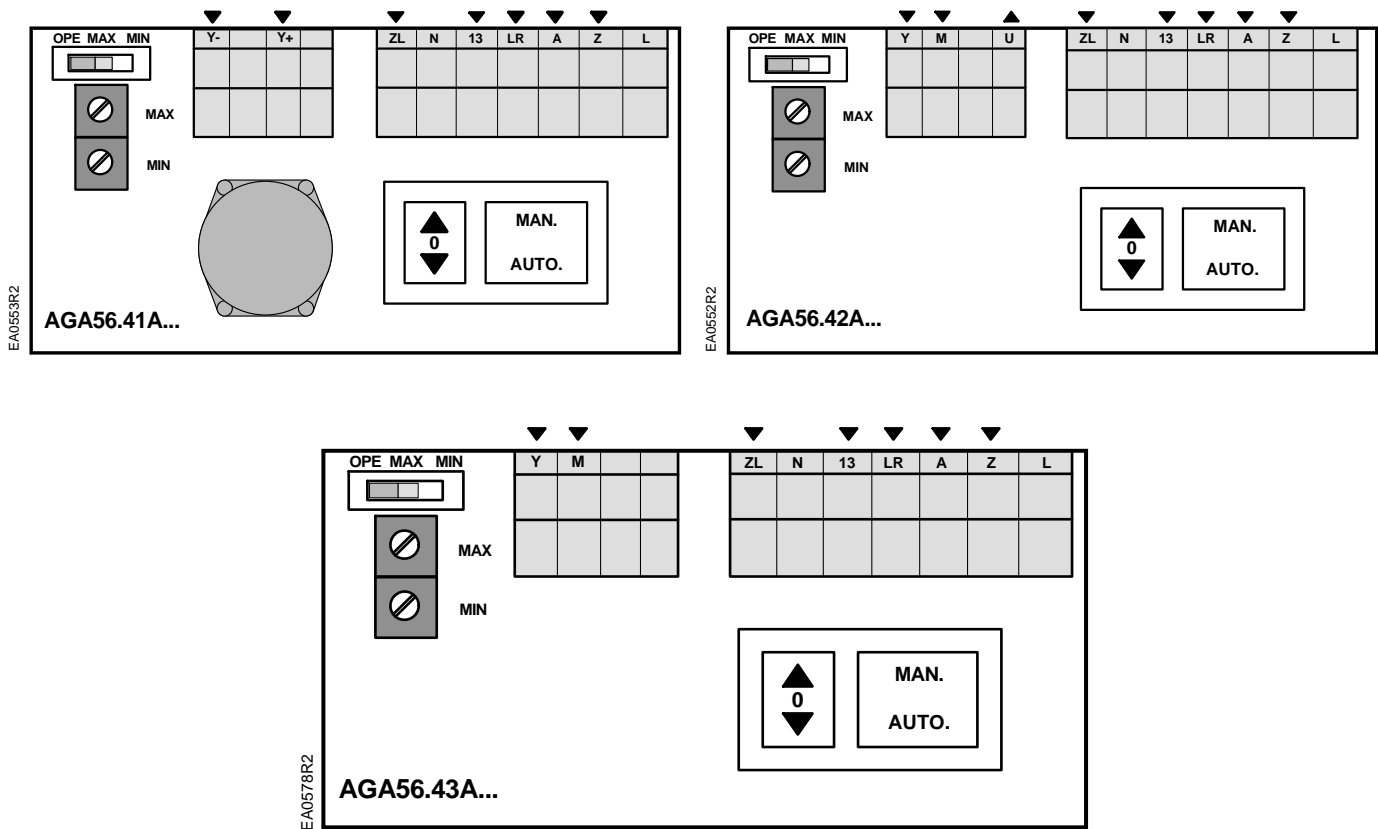

Figure 10. AGA56.41/42/43... Terminal/Trim Potentiometer Boards.

- AGA56.9...** circuit boards. 1. Connect line voltage to terminal L. Terminal L must be powered at all times.
- See *Figures 11 and 12.* 2. Connect neutral to terminal N.
3. Connect ground to the terminal located to the right of the auto/manual switch.
4. For applications where terminals Z, ZL and A are not used, bridge terminals L1 and L. If terminals Z, A or ZL are used, terminal L1 must not be bridged with terminal L. In addition, terminal L1 must never be powered simultaneously with terminals Z, A or ZL. However, terminal L1 must be powered once terminals A, Z and ZL are no longer powered and modulating operation is required (refer to application guide for typical installation examples).
5. Connect the input and output control signal wires to the appropriate terminals.

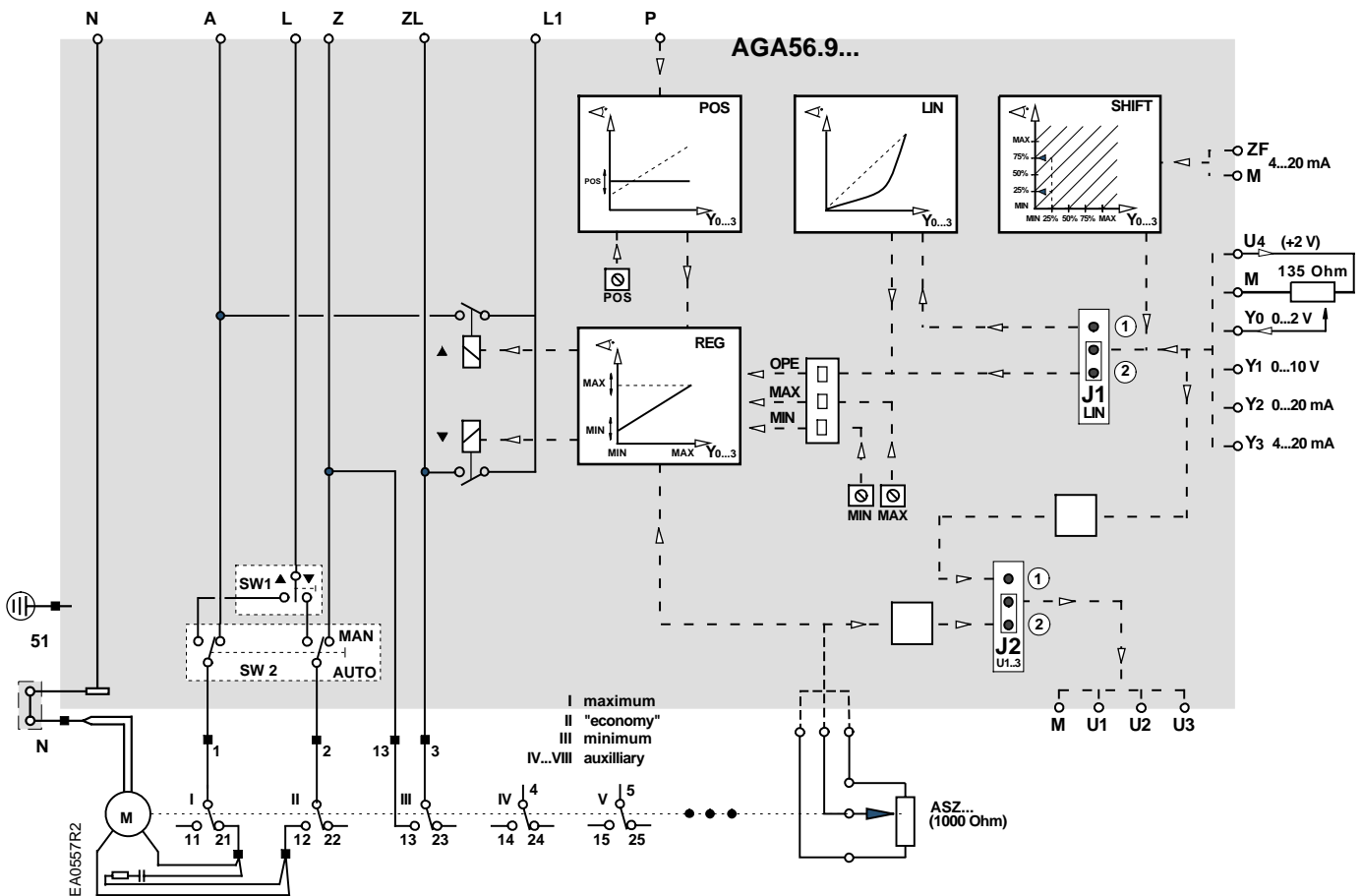

Figure 11. Basic Functional Diagram of AGA56.9...

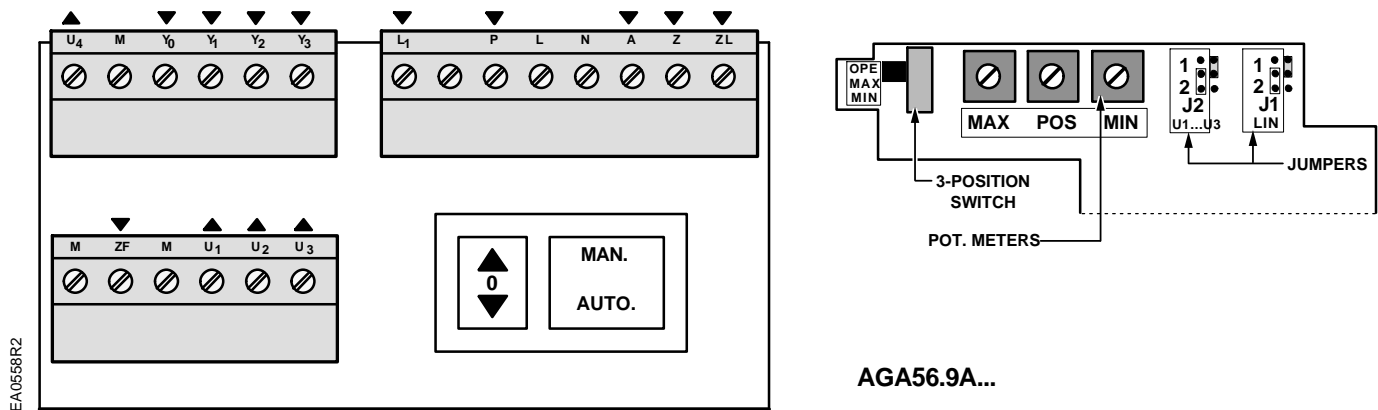

Figure 12. AGA56.9... Terminal and Trim Potentiometer/ Jumper Board.

Commissioning

Power Actuator

Set the auto/manual switch in the manual position and apply power to the actuator. The actuator can now be driven to the maximum position (switch cam I) or the full closed "economy position" (switch cam II) by using the toggle switch located to the left of the auto/manual switch.

Modulation Adjustment

See *Figures 10 and 12*.

Ensure that the OPE/MAX/MIN slide switch is set to operation (OPE). The blue MAX trim potentiometer should be gently turned in the clockwise direction until the end stop is reached. The blue MIN trim potentiometer should be gently turned in the counterclockwise direction until the end stop is reached. Set the auto/manual switch in the auto position. The actuator will now drive in response to the control input signal, between the maximum position setting (switch cam I) and the minimum position setting (switch cam III). If there is no control input signal, the actuator will drive to the minimum position setting (switch cam III).

NOTE: Switch Cam I must not be set higher than:

90° when using feedback potentiometers ASZxx..803,

135° when using feedback potentiometers ASZxx.833, or

160° when using feedback potentiometers ASZxx.863.

Zero Adjustment

See *Figures 10 and 12*.

Set the OPE/MAX/MIN slide switch to MIN. The blue MIN trim potentiometer can now be gently adjusted to the required minimum position.

Span Adjustment

See *Figures 10 and 12*.

Set the OPE/MAX/MIN slide switch to "MAX". The blue MAX trim potentiometer can now be gently adjusted to the required maximum position. Return the OPE/MAX/MIN slide switch to OPE.

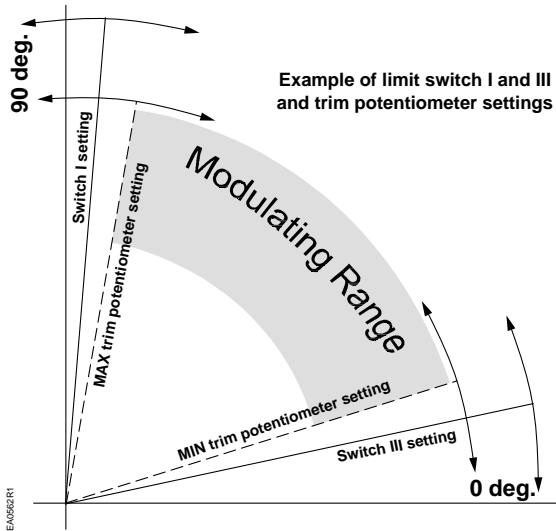

NOTE: The actual minimum and maximum modulating range is determined either by the setting of the MIN and MAX trim potentiometers or the setting of Switch Cam III (Minimum) and Switch Cam I (Maximum). The actuator can never modulate outside of the range set by switch cam I and III. If the MIN and MAX trim potentiometers are set outside the setting range of switch cams I and III, then the switch cam settings determine the modulating range. If a soft stop is desired, the modulating range can be defined by the trim potentiometers if the MIN and MAX trim potentiometers are set inside the setting range of switch cams I and III. See the example in *Figure 13*.

Figure 13. Switch cam and trim potentiometer setting.

Position Indicating Dial Adjustment

See *Figure 6*.

The **actual** position of the SQM5... actuator is indicated by the gray actuator position indicating pointer. The position is also indicated by the dial pointer. Ensure that the actuator position indicating dial is aligned with the actuator position scale by rotating the dial in the clockwise direction if necessary.



CAUTION:

Turning the dial in the counterclockwise direction may loosen the potentiometer locking screw.

Cover Installation

Lift the two screws on the cover corners and slide the cover end into the grooves at the gear end of the actuator. See *Figure 14*.

Press the cover into place and then press the screws inward and tighten. See *Figure 15*.

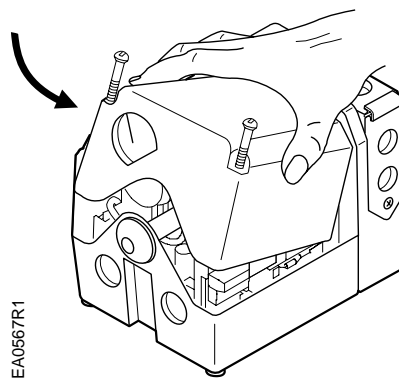

Figure 14.

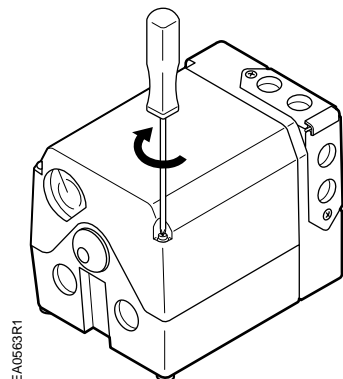

Figure 15.

Features of SQM5x.xxxxxZx Actuators

SQM5x.xxxxxZx actuators contain the AGA56.9A... multi function circuit board. This circuit board provides the following features:

Multiple Input Signals

The AGA56.9A... circuit board accepts the following input signals:

Line voltage

- Power to A drives the actuator open to the setting of switch cam I (Maximum).
- Power to ZL drives the actuator closed to the setting of switch cam III (Minimum).
- Power to Z drives the actuator closed to the setting of switch cam II (Economy).
- **4-20 mA** (Signal to Y3, common to M)
- **0-135 Ω** (Slide wire signal to Y0, potentiometer connected to M and U4)
- **0-10 Vdc** (Signal to Y1, common to M)
- **0-20 mA** (Signal to Y2, common to M)

Multiple Output Signals

The AGA56.9A... circuit board provides the following output signals:

- **4-20 mA** (Signal from U3, common to M)
- **0-10Vdc** (Signal from U1, common to M)
- **0-20mA** (Signal from U2, common to M)

Double potentiometers ASZ22... provide additional output signals.

Electronic Linearization Function

With jumper J1 in position 1 (upper position), the linearization function is enabled. The circuit board electronically converts the input signal to match the flow characteristics of a typical butterfly valve. Consequently, the actuator will make smaller rotational movements when subjected to lower input signals and larger rotational movements when subjected to higher input signals. For example (based on a 90° modulating range), a change in input signal from 4 to 8 mA (25% increase) will cause a rotational movement of 11.25°. An equal signal change from 16 to 20 mA will cause a rotational movement of 45°.

With jumper J1 in position 2 (lower position), the linearization function is disabled. When disabled, the rotational movement of the shaft is proportional to the input signal.

Input Signal Override

Line voltage to terminal P will drive the actuator to a pre-set adjustable position, overriding all modulating input signals. Use the potentiometer marked POS to adjust the override position to any setting within the setting range of switch cams I and III.

Parallel Operation

To configure the actuator for parallel operation, set the jumper J2 in position 1 (upper position). Input signals Y0, Y1, Y2 or Y3 are directly shunted to output signals U1, U2 and U3. All output signals are available regardless of which input signal is applied.

Master/Slave Operation

To configure the actuator for master/slave operation, set J2 in position 2 (lower position). The output signals U1, U2 and U3 reflect actual shaft position.

Split Ranging

AGA56.9... circuit boards have a modulating signal shift feature which can be used for split ranging. If no signal is present on Y0, Y1, Y2 or Y3, the actuator will modulate through the full rotational range in response to a 12 to 20 mA signal applied at ZF. If a

maximum signal is present on Y0, Y1, Y2, or Y3, then the actuator will modulate through the full rotational range in response to a 4 to 12 mA signal applied at ZF. (Maximum signal can be easily achieved by bridging terminals U4 and Y0.)

See Figure 16.

NOTE: It is possible to configure the actuator for split range operation 12 to 4 mA and 20 to 12 mA. Consult your authorized Siemens Building Technologies combustion products sales representative for details.

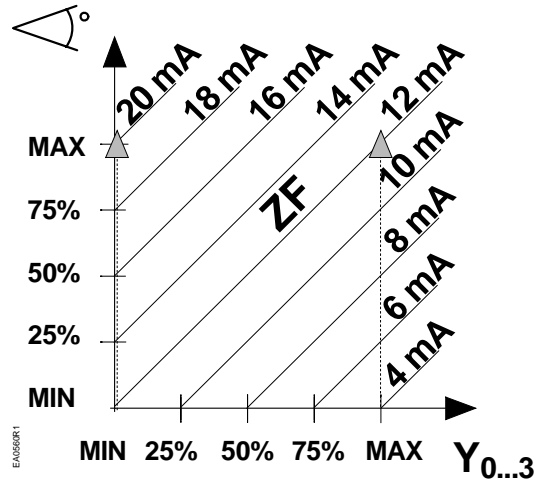

Figure 16. Split Ranging.

**Features of
SQM5x.xxxxxGx,
SQM5x.xxxxxHx,
SQM5x.xxxxxKx
Actuators**

SQM5x.xxxxxGx actuators contain the AGA56.41A... circuit board with terminals Y- and Y+ for 4-20 mA modulating input.

SQM5x.xxxxxHx actuators contain the AGA56.42A... circuit board with terminals Y, M and U for 0-135 Ω modulating input.

SQM5x.xxxxxKx actuators contain the AGA56.43A... circuit board with terminals Y and M for 0-10 Vdc modulating input.

Input Signals

The AGA56.4xA... circuit boards accept the following additional input signal:

Line voltage

- Power to A drives the actuator open to the setting of switch cam I (Maximum).
- Power to Z drives the actuator closed to the setting of switch cam II (Economy).
- Power to ZL drives the actuator closed to the setting of switch cam III (Minimum).

Output Signals

The AGA56.4xA... circuit boards do not provide output signals. Install a double potentiometer ASZ22...to obtain a 0-1000 Ω actuator position output signal.

Features of SQM5x.xxxxxAx Actuators

Input Signals

The AGA56.1A97... circuit boards accept the following additional input signal:

Line voltage

- Power to A drives the actuator open to the setting of switch cam I (Maximum).
- Power to Z drives the actuator closed to the setting of switch cam II (Economy).
- Power to switch III, terminal 3 drives the actuator to the setting of switch cam III (Minimum).

Output Signals

The AGA56.1A97 circuit board provides no output signals. Install a double potentiometer ASZ22...to obtain a 0-1000 Ω actuator position output signal.

Service Guide



WARNING:

Disconnect the power supply to the actuator before performing any service functions.

NOTE: Most SQM5... actuators are factory configured for counterclockwise (ccw), minimum to maximum rotation when facing the gear end of the actuator or clockwise (cw) rotation when facing the other end of the actuator.

Reversing Rotational Direction

1. Disconnect the double blue wires marked 21 and the double black wires marked 12 from switch I, terminal 21 and switch II, terminal 12 respectively.
2. Connect the double blue wires marked 21 to switch II, terminal 12. Connect the double black wires marked 12 to switch I, terminal 21.
3. See *Figure 6*. Adjust all switch cams to the desired settings using the red cam drum scales in combination with the double switch cam pointers.

NOTE: Press and hold the black cam drum release button to rotate the cam drum. This will give easy access to the switch cams and a better view of the cam drum scales.

4. If no potentiometer ASZ... is installed, the reversing procedure is complete. If a potentiometer ASZ... is installed, complete Steps 5 through 11.

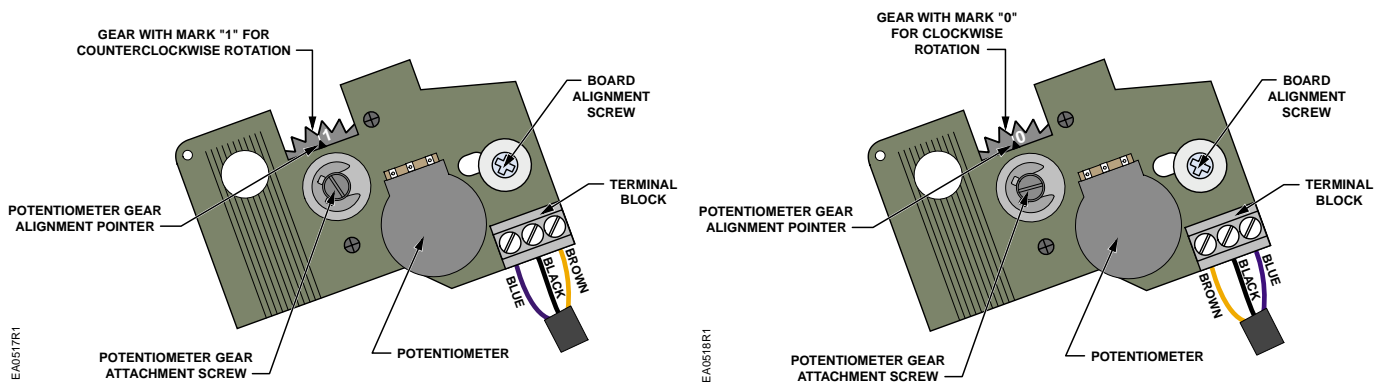

Figure 17. Reversing Rotational Direction on the ASZ Potentiometer Board.

5. See *Figure 17*. Disconnect the blue and brown wires from the terminal block located on the ASZ... potentiometer circuit board.

6. Reconnect the brown wire to the left terminal and the blue wire to the right terminal. The black wire remains connected to the middle terminal.
7. See *Figure 6*. Remove the white plastic actuator position-indicating dial by gently pulling while rotating in the clockwise direction.
8. The actuator position indicating pointer, located near the actuator gear end of the cam drum, must point to the "0" mark on the actuator position scale (scale on the cam drum nearest to the actuator gear end). Press and hold the black cam drum release button while manually rotating the cam drum.
9. See *Figure 17*. Loosen the black potentiometer gear attachment screw approximately one turn. Gently wedge a small screwdriver between the potentiometer gear and the gray plastic housing. Gently twist the screwdriver until the potentiometer gear releases from the cam drum shaft.
10. Manually rotate the potentiometer gear in the counterclockwise direction until the white line next to the "0" mark on the potentiometer gear face is **exactly** in alignment with the potentiometer gear alignment pointer. Firmly tighten the black potentiometer gear attachment screw while manually holding the potentiometer gear in alignment. Check the alignment again.
11. Re-install the white actuator-indicating dial by gently pressing it onto the potentiometer gear attachment screw. Align scale position "0" on the actuator position indicating dial with the dial pointer by rotating the dial in the clockwise direction to avoid loosening the potentiometer gear attachment screw.

Shaft Installation

See *Installation and Operation Instructions*.

Preparation before Circuit Board Installation



WARNING:

Disconnect the power supply to the actuator before replacing the circuit boards.

The black circuit board mounting bracket, installed on the inside base of the SQM5... actuator has four vertical, slotted circuit board supports. Remove the terminal section and circuit board(s) from the mounting bracket.

The actuator motor capacitor is attached to the lower section of the gray plastic switch housing using snap-on holding clips. Gently pull the capacitor forward until it unclips and temporarily place it on top of the gear housing. See *Figure 18*.

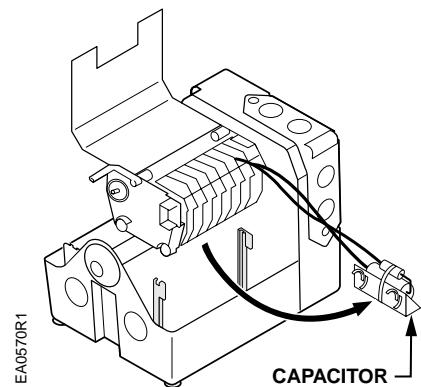

Figure 18.



CAUTION:

Do not disconnect any capacitor wiring.

AGA56.41/42/43 Circuit Board Installation

1. Remove the AGA56.41/42/43... circuit board from the packaging. The circuit board is shipped as one board.
2. Separate the board at the perforation by holding the circuit board at both ends and gently bending the board until it separates.
3. Move the terminal section containing the auto/manual switch to the opposite end of the base circuit board.
4. From the switch housing side of the actuator, guide the base circuit board into the bottom of the circuit board mounting bracket. See *Figure 19*.
5. Re-install the actuator motor capacitor. See *Figure 20*.
6. Connect the blue neutral wire, shipped loose with the AGA56.9A..., to the spade connector marked N located on the terminal board just below the auto/manual switch.
7. Gently guide the terminal section into the support slots and slide the terminal board downward until both supports snap into place. Ensure that the four brown wires and the flat white connector cable which connect the two circuit boards are positioned correctly in their respective corners allowing the board to freely slide into place without pinching either wire. See *Figure 21*.
8. Connect the bundled blue, black and brown potentiometer wires to the terminal block located on the ASZ... potentiometer circuit board. See *Potentiometer Installation*.

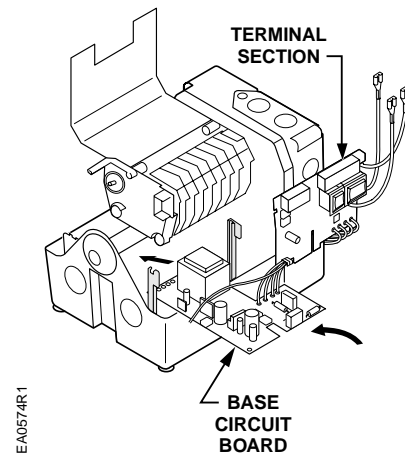

Figure 19.

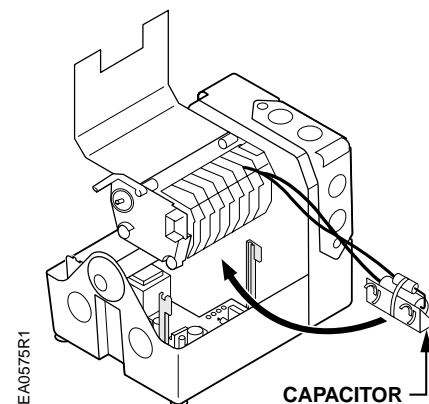

Figure 20.

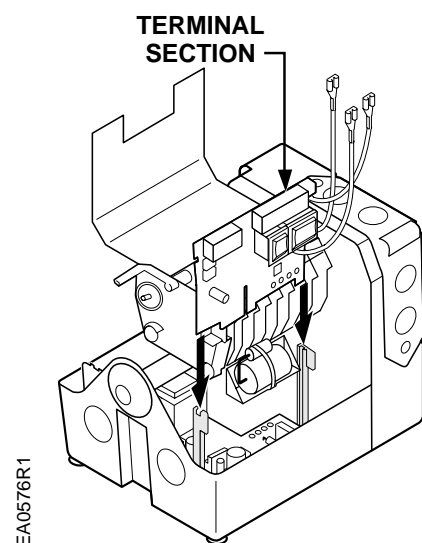
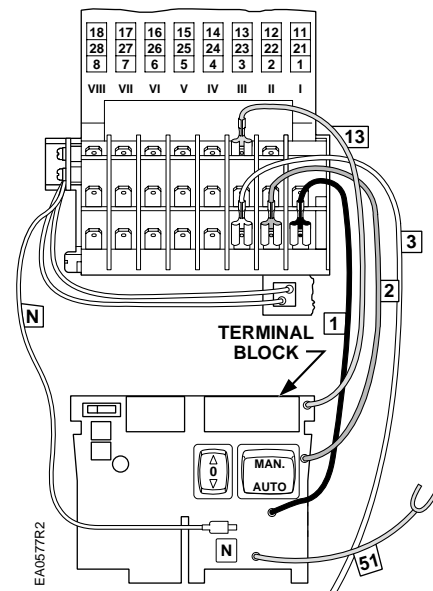

Figure 21.

**AGA56.41/42/43
Circuit Board
Installation, continued**

9. Make the following connections to the actuator: See *Figure 22*.
 - a. Connect the black wire, marked "1" from the circuit board to switch I, terminal 1.
 - b. Connect the yellow wire, marked "2" from the circuit board to switch II, terminal 2.
 - c. Connect the white wire, marked "3" from the circuit board to switch III, terminal 3.
 - d. Connect the brown wire, marked "13" from the circuit board to switch III, terminal 13.
 - e. Connect the other end of the blue neutral wire to the double terminal block located on the outer end of the switch housing
 - f. Connect the gray grounding wire marked "51" to the ground terminal located to the right of the auto/manual switch.

**Figure 22.****AGA56.9A...
Circuit Board Installation**

1. Remove the ASZ... potentiometer if already installed on the SQM5... actuator. See *Potentiometer Removal/Installation Instructions*.
2. Remove the AGA56.9A... circuit boards from the packaging. The three separate AGA56.9A circuit boards are shipped in a circuit board mounting bracket.
3. Remove the two upright circuit boards from the mounting bracket by gently pulling aside the vertical supports and sliding the boards upward. Remove the base circuit board from the bottom of the mounting bracket. Discard the shipping mounting bracket.

**AGA56.9A...
Circuit Board
Installation, continued**

4. Guide the base circuit board from the switch housing side of the actuator into the bottom of the circuit board mounting bracket. See *Figure 23*.
5. Re-install the actuator motor capacitor. See *Figure 24*.
6. Connect the blue neutral wire, shipped loose with the AGA56.9A..., to the spade connector marked N located on the terminal board just below the auto/manual switch.
7. Gently guide the terminal board into the support slots and slide the terminal board downward until both supports snap into place. See *Figure 25*.
8. See *Figure 26* and make the following connections to the actuator:
 - a. Connect the black wire, marked "1" from the circuit board to switch I, terminal 1.
 - b. Connect the yellow wire, marked "2" from the circuit board to switch II, terminal 2. Connect the white wire, marked "3" from the circuit board to switch III, terminal 3.
 - c. Connect the brown wire, marked "13" from the circuit board to switch III, terminal 13.
 - d. Connect the other end of the blue neutral wire to the double terminal block located on the outer end of the switch housing.
 - e. Connect the gray grounding wire marked "51" to the ground terminal located to the right of the auto/manual switch.

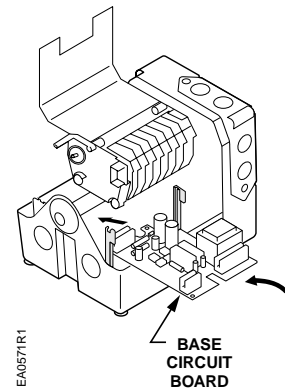

Figure 23.

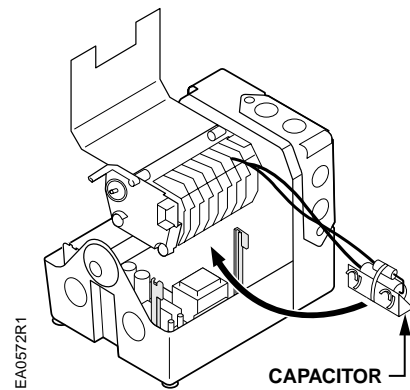

Figure 24.

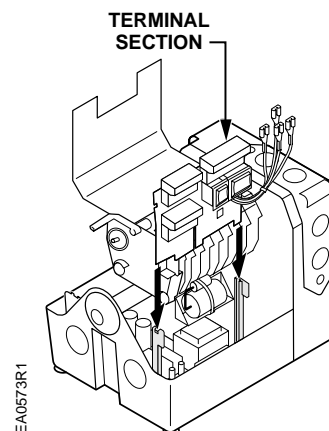

Figure 25

**AGA56.9A...
Circuit Board
Installation, continued**

9. Gently guide the L-shaped circuit board containing the three blue trim potentiometers into the vertical support slots located on the cam drum side of the actuator. See *Figure 27*.
10. Slide the circuit board downward until both supports snap into place. Install the ASZ... potentiometer (See *Potentiometer Removal/Installation Instructions*).
11. Connect the bundled blue, black and brown potentiometer wires to the terminal block located on the ASZ... potentiometer circuit board.

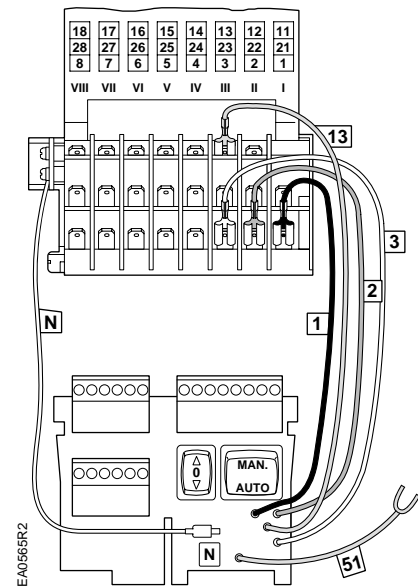

Figure 26.

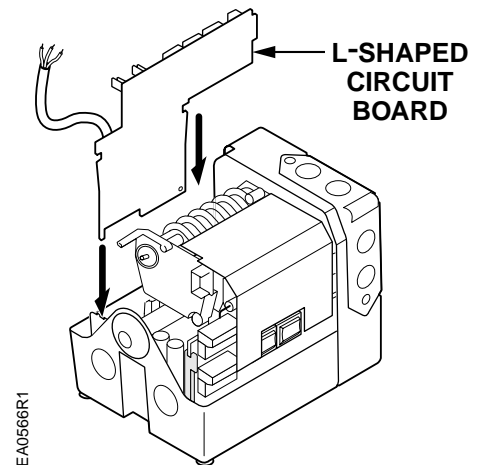

Figure 27.

**AGA56.1A97
Circuit Board Installation**

1. Install the AGA56.1A97 circuit board into the two slotted circuit board supports located on the switch housing side of the actuator.
2. Gently guide the AGA56.1A97 circuit board into the support slots and slide the board downward until both supports snap into place.
3. Make the following connections to the actuator:
 - a. Connect the black wire, marked "1" from the circuit board to switch I, terminal 1.
 - b. Connect the yellow wire, marked "2" from the circuit board to switch II, terminal 2.
 - c. Connect the brown wire, marked "13" from the circuit board to switch III, terminal 13.

Potentiometer Removal

1. Remove the white plastic actuator position-indicating dial by gently pulling while rotating in the clockwise direction. See *Figure 6*.
2. Disconnect the blue, black and brown wire from the potentiometer terminal block. See *Figure 17*.
3. Remove the silver potentiometer board alignment screw.
4. Loosen the black potentiometer gear attachment screw approximately one turn.
5. Gently wedge a small screwdriver between the potentiometer gear and the gray plastic housing.
6. Carefully twist the screwdriver until the potentiometer gear releases from the cam drum shaft. Remove the ASZ... potentiometer.

Potentiometer Installation

1. Install the new ASZ... potentiometer by gently sliding the bushing inserted in the gear over the cam drum shaft.
 2. Align the board alignment screw hole in the potentiometer board and install the board alignment screw. See *Figure 17*.
 3. The actuator position indicating pointer, located near the actuator gear end of the cam drum, must point to the "0" mark on the actuator position scale. See *Figure 6*. The scale is located on the cam drum nearest to the actuator gear end. Press and hold the black cam drum release button while manually rotating the cam drum.
 4. Manually rotate the potentiometer gear until the white line next to the "0" or "1" mark on the potentiometer gear face is **exactly** in alignment with the potentiometer gear alignment pointer. See *Figure 17*. For counterclockwise (ccw) operation the line beside the "1" mark must exactly align with potentiometer gear alignment pointer. For clockwise (cw) operation the line beside the "0" mark must exactly align with potentiometer gear alignment pointer. Firmly tighten the black potentiometer gear attachment screw while manually holding the potentiometer gear in alignment. Check the alignment again.
 5. Connect the bundled blue, black and brown potentiometer wires to the terminal block located on the ASZ... potentiometer circuit board. See *Potentiometer Installation* and *Figure 17*.
 6. Re-install the white actuator-indicating dial by gently pressing it onto the potentiometer gear attachment screw. Align scale position "0" on the actuator position indicating dial with the dial pointer by rotating the dial in the clockwise direction to avoid loosening the potentiometer gear attachment screw. See *Figure 6*.
-

Specifications**SQM5... Reversing actuator****SQM5... Reversing actuator**

Agency approvals	UL, CSA, CE
Operating voltage	24 Vac +10%-15% 110 Vac-15% to 120 Vac +10% 220 Vac-15% to 240 Vac +10%
Operating frequency	50-60 Hz
Power consumption	20 VA
Type of motor	Reversing synchronous motor
Duty cycle	100%
Torque	See <i>Table 1</i> .
Maximum shaft torque	
AGA58.1	90 lb-in
AGA58.2	200 lb-in
AGA58.3	220 lb-in
AGA58.4	270 lb-in
AGA58.7	350 lb-in
Timings	See <i>Table 1</i> .
Rotational range of operation	
SQM5x.xxxxxA models	0-160°
SQM5x.xxxxx3 models	0-90°
SQM5x.xxxxx4 models	0-135°
SQMSx.xxxxx6 models	0-160°
Direction of rotation	Reversible, factory setting: ccw
Shaft	Selectable. See <i>Table 2</i> . Custom versions on request
Shaft disengagement	Independent, cam and drive shaft
Number of auxiliary switches	6 switches (maximum)
Limit switches	2 switches (standard)
Electrical rating of auxiliary switches	7.5 (3) A, 250 Vac
Mounting position	Optional
Ambient operating temperature	-5 to 140°F (-20 to 60°C)
Shipping temperature	-58 to 140°F (-50 to 60°C)
NEMA ratings	NEMA 1, 2, 3, 3R, 3S, 5, 12, and 13
Connections	
Switches	Spade connectors
Boards	Screwed and spade connectors
Dimensions	See <i>Figures 28</i> through <i>31</i> .
Weight	7.3 lbs. (3.3 kg)
Housing	Aluminum pressure die casting
Enclosure (cover)	Lexan
Motor	Lock resistant
Disengagements	Manual for drive and cam shaft

Conduit connection	Two removable inserts with two 1/2-inch NPSM threads. Each insert allows insertion of entire cable tree for easy servicing
Gears and bearings	Maintenance free
Mounting	Four 1/4"-20 UNC screws in bottom Face mounting at gear side also possible
Adaptation to other actuator brands	Screw pattern and shaft height Adaptation with AGA57... adapters See <i>Table 2</i> .

Circuit Boards

AGA56.1A97

AGA56.1A97 Switch circuit board

Operating voltage	Voltage independent
Operating frequency	50-60 Hz
Auto/manual switch	2-position switch
Manual toggle switch	3-position switch
Ambient operating temperature	-5 to 140°F (-20 to 60°C)
Shipping temperature	-58 to 140°F (-50 to 60°C)
Weight	0.22 lb. (0.1 kg)

AGA56.41A...

AGA56.41A... Electronic circuit boards

Operating voltage	24 Vac +10%-15% 110 Vac -15% to 120 Vac +10% 220 Vac -15% to 240 Vac +10%
Operating frequency	50-60 Hz
Ambient operating temperature	-5 to 140°F (-20 to 60°C)
Shipping temperature	-58 to 140°F (-50 to 60°C)
Input signal	4-20 mA
Impedance	

Current input $\leq 300 \Omega$

Zero adjustment MIN: 0-75 %

Span adjustment MAX: min-100 %

Auto/manual switch 2-position switch

Manual toggle switch 3-position switch

Weight 0.7 lb. (0.33 kg)

AGA56.42A...

AGA56.42A... Electronic circuit boards

Same specifications as AGA56.41A except

Input signal 0-135 Ohm

Impedance

Current input $\leq 300 \Omega$

Voltage input $\geq 100k\Omega$

**Specifications,
continued**

AGA56.43A...	AGA56.43A... Electronic circuit boards	Same specifications as AGA56.41A except:
	Input signal	0-10 Vdc
	Impedance	
	Voltage input	$\geq 100\text{k}\Omega$
AGA56.9A	AGA56.9A... Multi function electronic circuit boards	Single potentiometer ASZ... (1000 ohm) is required
	Operating voltage	24 Vac +10%-15% 110 Vac -15% to 120 Vac +10% 220 Vac -15% to 240 Vac +10%
	Operating frequency	50-60 Hz
	Input signals	4-20 mA, 0-20 mA, 0-10 Vdc, 0-135 ohm
	Impedance	
	Current input	$\leq 300\ \Omega$
	Voltage input	$\geq 100\text{k}\Omega$
	Output signals	4-20 mA 0-20 mA, 0-10Vdc
	Zero adjustment	MIN: 0-75 %
	Span adjustment	MAX: min-100 %
	Split ranging (SHIFT)	4-20 mA on terminal ZF
	Input signal override (POS)	Line voltage (... Vac) on terminal P adjust with POS potentiometer
	Ambient operating temperature	-5 to 140°F (-20 to 60°C)
	Shipping temperature	-58 to 140°F (-50 to 60°C)
	Auto/manual switch	2-position switch
	Manual toggle switch	3-position switch
	Weight	0.7 lb. (0.33 kg)
ASZ... Potentiometers	ASZ... Potentiometers	
	Versions	Single and double potentiometer
	Resistor values	See <i>Table 2</i> and <i>data sheet 7921</i> .
	Hysteresis	< 0.3 % related to drive shaft

Dimensions

The first dimension given is measured in inches. Millimeters are shown in parentheses.

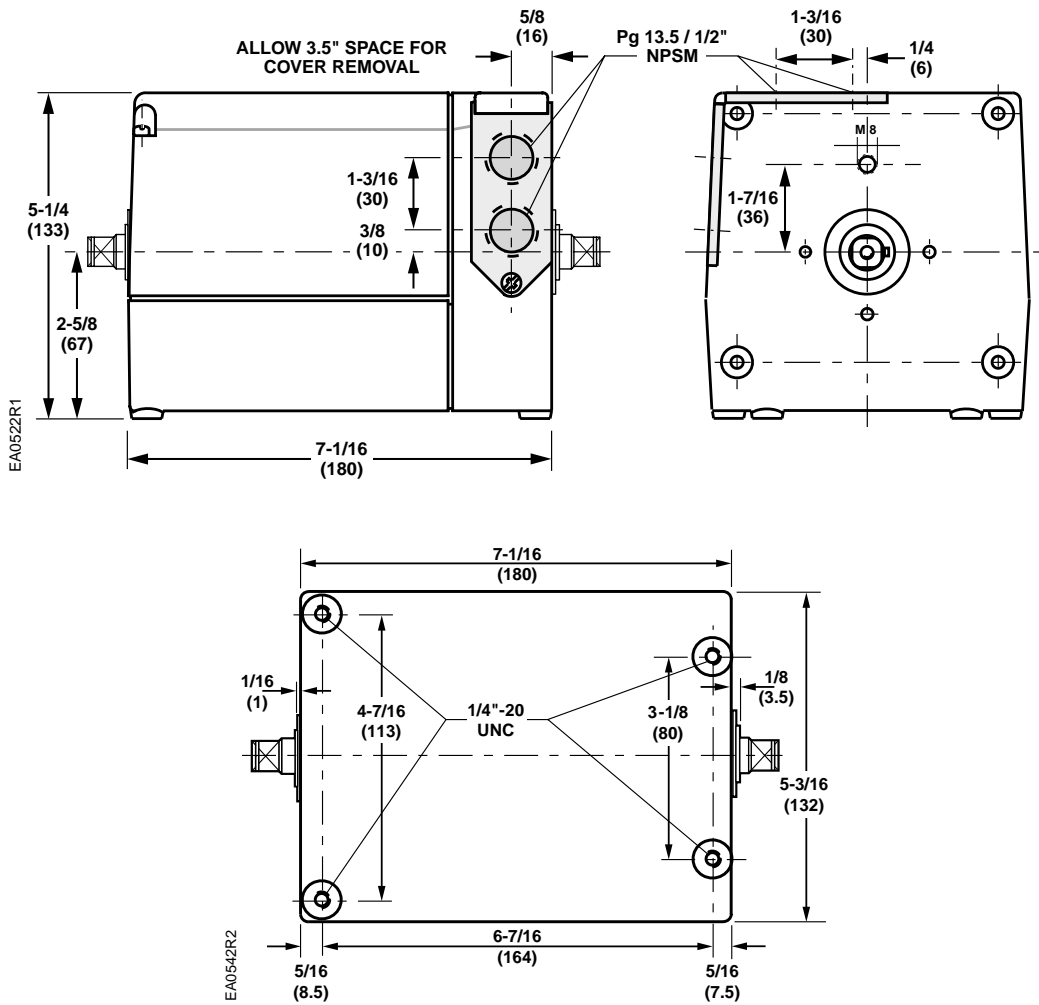

Figure 28. SQM5x.xxxRxx Dimensions.

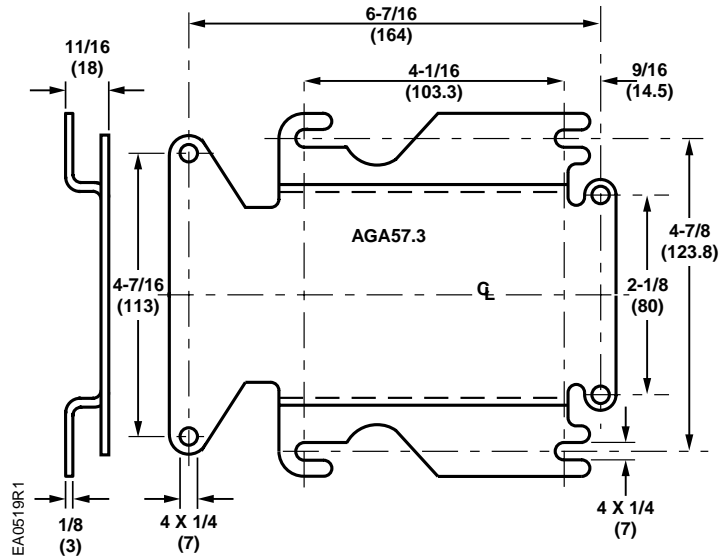

Figure 29. Mounting Bracket AGA57.3

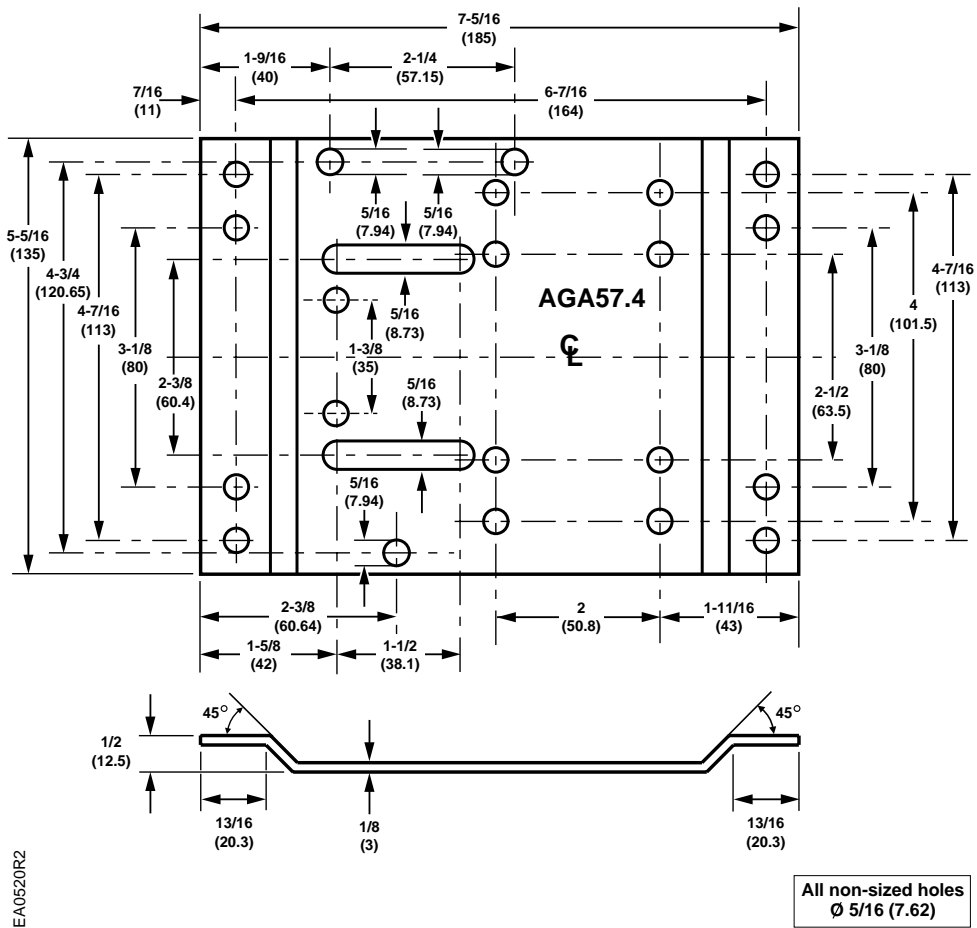

Figure 30. AGA57.4 Mounting Bracket.

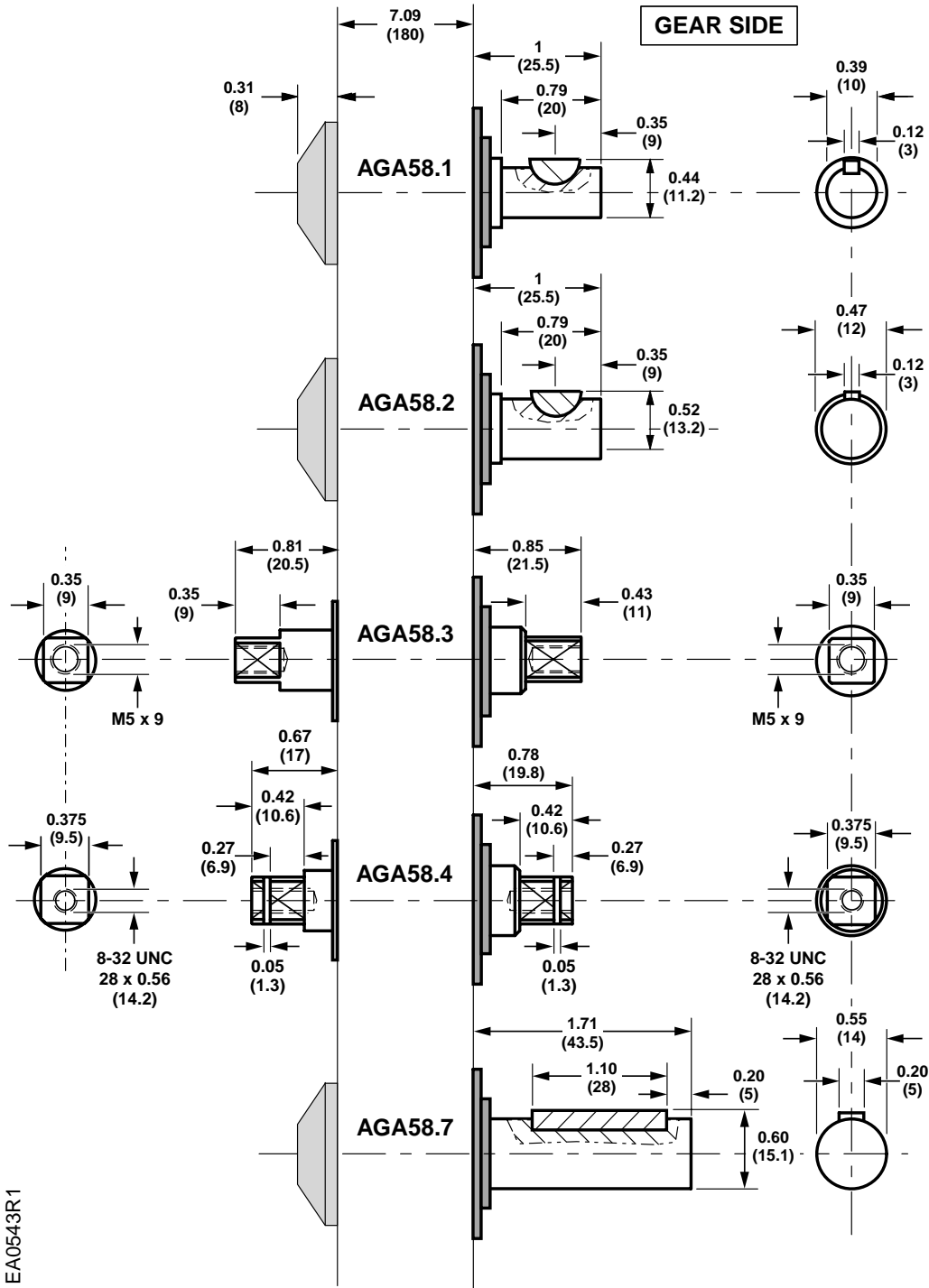

Figure 31. Shaft Dimensions.

Information in this publication is based on current specifications. The company reserves the right to make changes in specifications and models as design improvements are introduced. © 2000 Siemens Building Technologies, Inc.