

### Base attachment FDB291

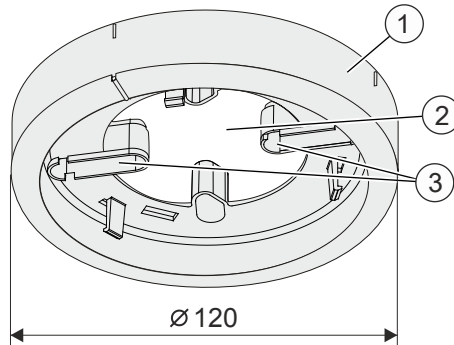

#### Function:

- For routing surface-mounted cables larger than  $\varnothing$  6 mm
- Detector base is secured with a snap fastener



- |   |                                                                                                                     |   |                |
|---|---------------------------------------------------------------------------------------------------------------------|---|----------------|
| 1 | <ul style="list-style-type: none"><li>• Base height: 25 mm</li><li>• When using the point detector: 60 mm</li></ul> | 3 | Mounting slits |
| 2 | Opening for cable entry                                                                                             |   |                |

### Base attachment humid FDB293



- For achieving a higher protection category
- For mounting in wet or humid environments
- Required when using detector heating unit FDBH291
- Required when using protective cage DBZ1194 or EMC-protective cage FDBZ294
- Mounted between detector base and ceiling
- Detector base mounted quickly: The detector base simply clicks into place in base attachment humid FDB293.

### Base attachment wet FDB295



- Base attachment wet with additional integrated rubber seal for mounting in wet or humid environments
- For achieving a higher protection category
- For mounting in wet or humid environments
- Required when using detector heating unit FDBH291
- Required when using protective cage DBZ1194
- Mounted between detector base and ceiling
- Detector base mounted quickly: The detector base simply clicks into place in base attachment wet FDB295.