



2-port valves
VVP45.10-0.25 to VVP45.25-4



3-port valves
VXP45.10-0.25 to VXP45.25-6.3



3-port valves with T-bypass
VMP45.10-0.25 to VMP45.20-4



2-port valves
VVP45.25-6.3 to VVP45.40-25



3-port valves
VXP45.25-10 to VXP45.40-25

ACVATIX™

2-port and 3-port valves PN 16

VVP45..
VXP45..
VMP45..

- Bronze CC499K valve body
- DN 10...DN 40
- k_{vs} 0.25...25m³/h
- Flat seal male threaded connections G...B to ISO 228-1 for
 - Sets of ALG.. screwed fittings with threaded connection (available from Siemens)
 - SERTO compression fittings, type SO 00021.. (available from suppliers to the trade)
- Manual adjuster
- Can be equipped with SSB.. or SSC.. electromotoric actuators

Use

- In ventilation and air-conditioning systems for water-side terminal unit control in closed circuits, e.g. induction units, fan coil units, small reheaters and small re-coolers, for use in:
 - 2-pipe systems with one heat exchanger for heating and cooling
 - 4-pipe systems with two separate heat exchangers for heating and cooling
- In closed-circuit zone heating systems, e.g.
 - Individual floors in a building
 - Apartments
 - Individual rooms

Type summary

VVP45.. 2-port	VXP45.. 3-port	VMP45.. 3-port with T-bypass	DN	Connection	k_{vs} A → AB [m ³ /h]	$k_{vs}^{1)}$ B → AB [m ³ /h]	S_v
VVP45.10-0.25	VXP45.10-0.25	VMP45.10-0.25	10	G ½B	0.25	0.18	> 50
VVP45.10-0.4	VXP45.10-0.4	VMP45.10-0.4			0.4	0.28	
VVP45.10-0.63	VXP45.10-0.63	VMP45.10-0.63			0.63	0.44	
VVP45.10-1	VXP45.10-1	VMP45.10-1			1.0	0.70	
VVP45.10-1.6	VXP45.10-1.6	VMP45.10-1.6			1.6	1.12	
VVP45.15-2.5	VXP45.15-2.5	VMP45.15-2.5	15	G ¾B	2.5	1.75	> 100
VVP45.20-4	VXP45.20-4	VMP45.20-4	25	G 1B	4.0	2.80	
VVP45.25-6.3	VXP45.25-6.3			G 1¼B	6.3	4.40	
VVP45.25-10	VXP45.25-10		G 1½B	10			
VVP45.32-16	VXP45.32-16		32	G 2B	16		
VVP45.40-25	VXP45.40-25		40	G 2¼B	25		

1) Valid for 3-port version only

DN = Nominal size

k_{vs} = Nominal flow rate of cold water (5...30 °C) through the fully open valve (H_{100}) by a differential pressure of 100 kPa (1 bar)

S_v = Rangeability k_{vs} / k_{vr}

k_{vr} = Smallest k_v value, at which the flow characteristic tolerances can still be maintained, by a differential pressure of 100 kPa (1 bar)

Accessories

Product no.	Stock no.	Description
ALG..2	ALG..2	Set of 2 fittings with threaded connections for 2-port valves, consisting of 2 union nuts, 2 discs and 2 flat seals. ALG..2B are brass fittings, for media temperatures up to 100 °C.
ALG..2B	S55846-Z1..	
ALG..3	ALG..3	Set of 3 fittings with threaded connections for 2-port valves, consisting of 3 union nuts, 3 discs and 3 flat seals. ALG..2B are brass fittings, for media temperatures up to 100 °C.
ALG..3B	S55846-Z1..	

Ordering

Example:

Product number	Stock no.	Description	Quantity
VVP45.15-2.5	VVP45.15-2.5	2-port valve	20
ALG142	ALG142	Set of 2 fittings	20
VMP45.20-4	VMP45.20-4	3-port valve with T-bypass	10
ALG152B	S55846-Z100	Set of 3 fittings	20

For 3-port valves with T-bypass VMP45..order two sets of 3 screwed fittings.

Delivery

Valves, actuators and accessories are packed and supplied separately.

Spare parts, rev. no.

See overview, page 10.

Equipment combinations

Valves	Actuators				Set of fittings		
	SSB..		SSC..		Malleable cast iron Type / Stock no.	Brass	
	Δp_{\max}	Δp_s	Δp_{\max}	Δp_s		Type	Stock no.
	[kPa]						
VVP45.10-0.25 to 1.6	400	725				ALG132 ¹⁾	ALG132
VVP45.15-2.5	350	350				ALG142 ¹⁾	ALG142
VVP45.20-4	350	350	350	350	ALG152	ALG152B ²⁾	S55846-Z100
VVP45.25-6.3	300	300	300	300	ALG202	ALG202B ²⁾	S55846-Z102
VVP45.25-10			300	300	ALG252	ALG252B ²⁾	S55846-Z104
VVP45.32-16			175	175	ALG322	ALG322B ²⁾	S55846-Z106
VVP45.40-25			75	75	ALG402	ALG402B ²⁾	S55846-Z108
VXP45.10-0.25 to 1.6	400					ALG133 ¹⁾	ALG133
VXP45.15-2.5	350					ALG143 ¹⁾	ALG143
VXP45.20-4	350		350		ALG153	ALG153B ²⁾	S55846-Z101
VXP45.25-6.3	300		300		ALG203	ALG203B ²⁾	S55846-Z103
VXP45.25-10			300		ALG253	ALG253B ²⁾	S55846-Z105
VXP45.32-16			175		ALG323	ALG323B ²⁾	S55846-Z107
VXP45.40-25			75		ALG403	ALG403B ²⁾	S55846-Z109
VMP45.10-0.25 to 1.6	400					2 x ALG132 ¹⁾	ALG132
VMP45.15-2.5	350					2 x ALG142 ¹⁾	ALG142
VMP45.20-4	350				2 x ALG152	2 x ALG152B ²⁾	S55846-Z100

¹⁾ Connecting thread pipe side: Internally threaded

²⁾ Usable up to maximum medium temperature of 100 °C

Δp_{\max} = Maximum permissible differential pressure across valve's control path, valid for the entire actuating range of the motorized valve.

Δp_s = Maximum permissible differential pressure at which the motorized valve will close securely against the pressure (close off pressure).

Actuator overview

Type reference	Operating voltage	Positioning signal	Positioning time	Positioning force	for valves with k_{vs}	Data sheet
SSB31..	AC 230 V	3-position	150 s	200 N	to 6.3 m ³ /h	N4891
SSB81..	AC 24 V					
SSB61..	AC/DC 24 V	DC 0...10 V	75 s			
SSC31..	AC 230 V	3-position	150 s	300 N	from 4 m ³ /h	N4895
SSC81..	AC 24 V					
SSC61..	AC/DC 24 V					

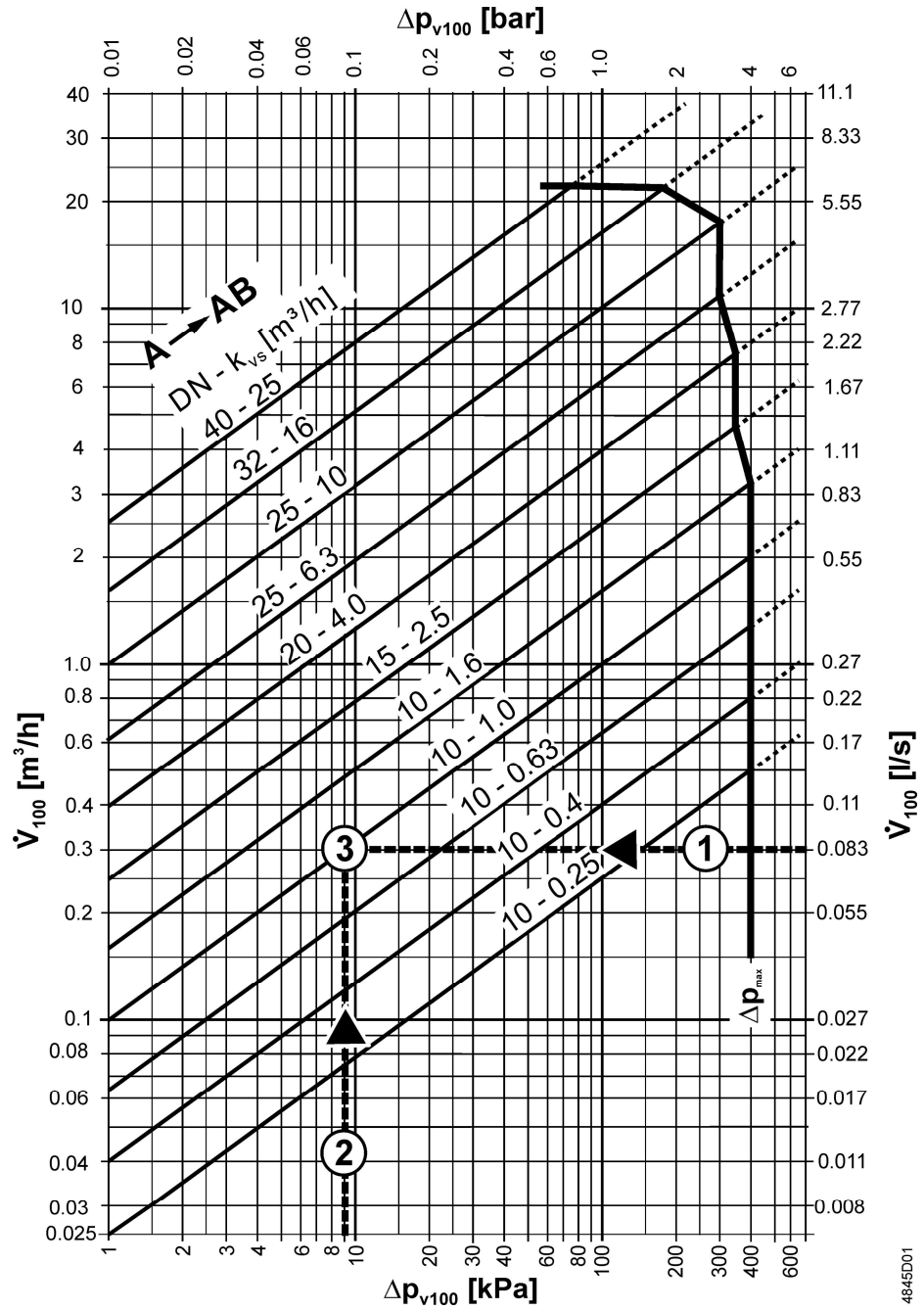

- Δp_{max} = Maximum permissible differential pressure across the valve's control path, valid for the entire actuating range of the motorized valve
- Δp_{V100} = Differential pressure across the fully open valve and the valve's control path by a volume flow V_{100}
- \dot{V}_{100} =
- 100 kPa = 1 bar \approx 10 mWS
- 1 m³/h = 0.278 l/s water at 20 °C

Example:

1	\dot{V}_{100}	= 0.083 l/s
2	Δp_{V100}	= 9 kPa
3	$\rightarrow k_{vs}$ -value	= 1.0 m ³ /h

Valve flow characteristic

V..45.10-0.25 to V..45.25-6.3

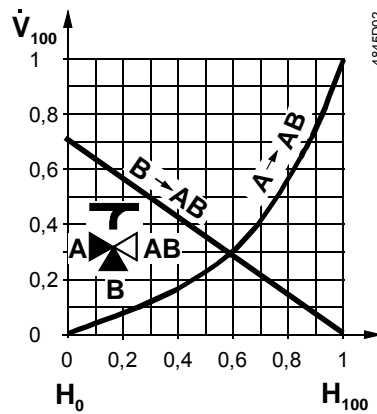

V..P45.25-10 to V..P45.40-25

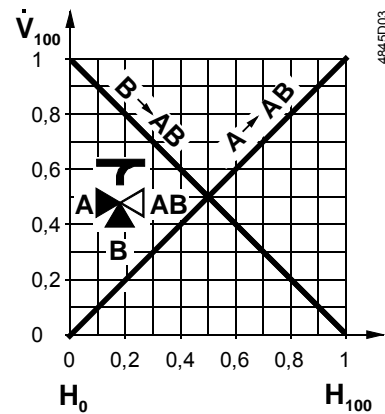

The k_{vs} -values in bypass B for valve types V..45.10-0.25 to V..45.25-6.3 represent only 70 % of the k_{vs} -value in the straight-through control path A → AB (for other types 100 %). This compensates for the flow resistance of the heat exchanger or radiator, so keeping the overall flow rate, \dot{V}_{100} as constant as possible.

Engineering notes

Valve construction	Valve series	Valve flow in control mode			Valve stem	
		Inlet A	Inlet B	Outlet AB	Retracted	Extended
<p>2-port valves</p> <p>4845Z12</p>	<p>VVP45..</p>	variable		variable	A → AB opens	A → AB closes
<p>3-port valves</p> <p>4845Z13</p>	<p>VXP45..</p>	variable	variable	constant	A → AB opens B → AB closes	A → AB closes B → AB opens
<p>3-port valves with T-bypass</p> <p>4845Z14</p>	<p>VMP45..</p>	variable	variable	constant	A → AB opens B → AB closes	A → AB closes B → AB opens

Warning!

The direction of flow **MUST** be as indicated by the arrow, i.e. only from A → AB and B → AB.

The 3-port valve types VXP45.. and VMP45.. may only be used in mixing applications

We recommend installation in the return pipe, as the temperatures in this pipe are lower for applications in heating systems, which in turn, extends the stem sealing gland's life.

Recommendation: Always use a strainer upstream of the valve to increase the valve's functional safety.

Mounting notes

Both valve and actuator can easily be assembled at the mounting location. Neither special tools nor adjustments are required.

The valve is supplied with Mounting Instructions 4 319 9526 0.

Orientation

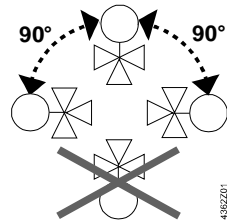

Commissioning notes



Commission the valve only if the manual knob or actuator has been mounted correctly.

Manual adjustment

The straight-through path A → AB can be opened electrically via the actuator, or manually. With three-port valves, this throttles or closes bypass B.

Manually, path A → AB can only be opened to 70 % (bypass closes to 30 %). The valves with k_{vs} values 10, 16 and 25 can be fully opened whereas the bypass can be fully closed.

The valves are closed by a return spring.

Maintenance

Warning 

V..P45.. valves require no maintenance.

When doing service work on the valve / actuator:

- Deactivate the pump and turn off the power supply
- Close the shutoff valves
- Fully reduce the pressure in the piping system and allow pipes to completely cool down

If necessary, disconnect the electrical wires.

Before putting the valve into operation again, make certain the manual knob or the actuator is correctly fitted.

Stem sealing gland

The stem sealing gland cannot be exchanged. In the case of leakage, the entire valve must be replaced. Contact your local office or branch.

Disposal

Do not dispose of the device as household waste.

 Warning

Due to the tensioned spring return, valve disassembly may result in flying parts causing possible injury.

Only authorized staff may disassemble valves with tensioned spring return!

Disposal

- Special handling of individual components may be mandated by law or make ecological sense.
- Observe all local and currently applicable laws and regulations.

Warranty

The technical data given for these applications is valid only in conjunction with the Siemens actuators as detailed under «Equipment combinations».

All terms of the warranty will be invalidated by the use of actuators from other manufacturers.

Technical data

Functional data	PN class	PN16 to EN 1333
	Permissible operating pressure	1600 kPa (16 bar) to ISO 7628 / EN 1333
	Valve flow characteristic	
	Through-port A → AB	to k_{vs} 6.3 equal percentage; $n_{gl} = 2.2$ to VDI / VDE 2173
	Through-port A → AB	from k_{vs} 10 linear
	Bypass B → AB	linear
	Leakage rate	
	Through-port A → AB	to DIN EN 1349
		0...0.02 % of k_{vs} -value
	Bypass B → AB	0...0.02 % of k_{vs} -value
	Permissible media	
		low temperature hot water, chilled water, water with anti-freeze recommendation: water treatment to VDI 2035
	Medium temperature	1...110 °C, short-term max. 120 °C
Rangeability S_v	> 50 resp. > 100 (refer to «Type summary»)	
Nominal stroke	5.5 mm	
Materials	Valve body	bronze CC499K
	Stem	stainless steel
	Plug, seat, gland	brass
	Sealing gland	EPDM-O-rings
	Fitting bypass	
		VVP45..., k_{vs} 6.3 to 25: union nut Malleable cast iron disc Stainless steel gasket Klinger SIL C-4300
Dimensions / Weight	Dimensions refer to «Dimensions»	
	Threaded connections	
	Valve	G...B to ISO 228-1
	Screwed fittings	R/Rp... to ISO 7-1, G... to ISO 228-1
	Actuator connection	G 3/4"
Weight	refer to «Dimensions»	
Standards, directives and approvals	Pressure Equipment Directive	PED 2014/68/EU
	Pressure Accessories	Scope: Article 1, section 1 Definitions: Article 2, section 5
	Fluid group 2	without CE-marking as per article 4, section 3 (sound engineering practice) ¹⁾
	EAC Conformity	Eurasia Conformity
Environmental compatibility	The product environmental declaration CE1E4845en ²⁾ contains data on environmentally compatible product design and assessments (RoHS compliance, materials composition, packaging, environmental benefit, disposal).	

¹⁾ Valves where $PS \times DN < 1000$, do not require special testing and cannot carry the CE label.

²⁾ The documents can be downloaded from <http://siemens.com/bt/download>.

Dimensions

2-port valves VVP45..

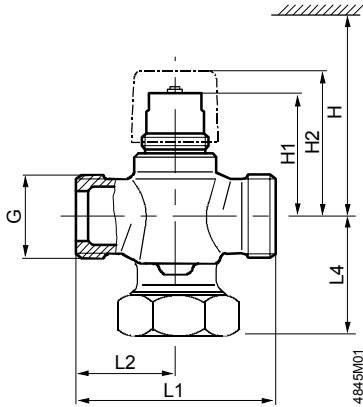

3-port valves VXP45..

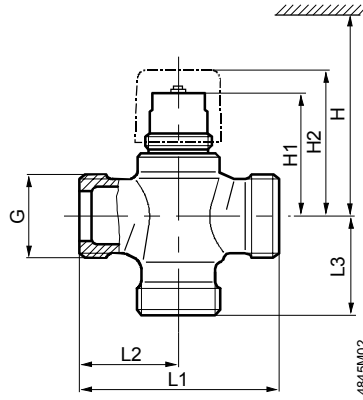

3-port valves with T-bypass VMP45..

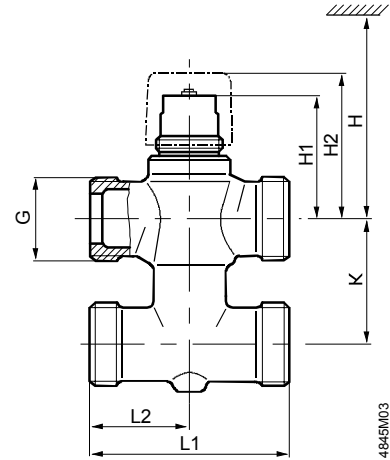

Type reference	DN	G [inch]	H [mm]	H1 [mm]	H2 [mm]	L1 [mm]	L2 [mm]	L4 [mm]	Weight [kg]
VVP45.10-0.25...1.6	10	G ½B	> 200	44.9	≈ 54	60	30	20	0.26
VVP45.15-2.5	15	G ¾B		44.9	≈ 54	65	32,5	20	0.30
VVP45.20-4	20	G 1B		48.9	≈ 58	80	40	24	0.42
VVP45.25-6.3	25	G 1¼B		51	≈ 60	80	40	49	0.76
VVP45.25-10		G 1½B	62.5	≈ 71	105	52.5	62.5	1.40	
VVP45.32-16	32	G 2B	> 280	69	≈ 78	105	52.5	63.5	1.95
VVP45.40-25	40	G 2¼B		72	≈ 81	130	65	76	2.75

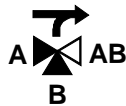

Type reference	DN	G [inch]	H [mm]	H1 [mm]	H2 [mm]	L1 [mm]	L2 [mm]	L3 [mm]	Weight [kg]
VXP45.10-0.25...1.6	10	G ½B	> 200	44.9	≈ 54	60	30	30	0.28
VXP45.15-2.5	15	G ¾B		44.9	≈ 54	65	32.5	32.5	0.34
VXP45.20-4	20	G 1B		48.9	≈ 58	80	40	40	0.48
VXP45.25-6.3	25	G 1¼B		51	≈ 60	80	40	40	0.64
VXP45.25-10	25	G 1½B	> 280	62.5	≈ 81	105	52.5	52.5	1.20
VXP45.32-16	32	G 2B		69	≈ 88	105	52.5	52.5	1.60
VXP45.40-25	40	G 2¼B		72	≈ 91	130	65	65	2.30



Type reference	DN	G [inch]	H [mm]	H1 [mm]	H2 [mm]	K [mm]	L1 [mm]	L2 [mm]	Weight [kg]
VMP45.10-0.25...1.6	10	G ½B	> 200	44.9	≈ 54	40	60	30	0.36
VMP45.15-2.5	15	G ¾B		44.9	≈ 54	40	65	32.5	0.46
VMP45.20-4	20	G 1B		48.9	≈ 58	50	80	40	0.64

Sets of screwed fittings with flat seal available from Siemens ALG...2: set of 2 screwed fittings ALG...3: set of 3 screwed fittings	ALG132 ALG133 ALG142 ALG143	pipe side with externally R threads	
	ALG152 ALG153 ALG202 ALG203 ALG252 ALG253 ALG322 ALG323 ALG402 ALG403	ALG152B ALG153B ALG202B ALG203B ALG252B ALG253B ALG322B ALG323B ALG402B ALG403B	pipe side with internally Rp threads
Compression fittings (available from suppliers to the trade)	SERTO SO 00021..		

Type ALG..		for valve type	DN	G	R	Rp	L	T	Type SERTO SO 00021.. ¹⁾	D	
Malleable cast iron	Brass ¹⁾			[Inch]	[Inch]	[Inch]	[mm]	[mm]	www.serto.com	[mm]	
	ALG132	VVP45.10-0.25...1.6	10	G½	R¾		≈ 24	≈ 9	SO 00021-12-1/2"	12	
	ALG133	VXP45.10-0.25...1.6							SO 00021-14-1/2"	14	
	2 x ALG132	VMP45.10-0.25...1.6							SO 00021-15-1/2"	15	
	ALG142	VVP45.15-2.5	15	G¾	R½		≈ 29,5	≈ 12	SO 00021-17-3/4"	17	
	ALG143	VXP45.15-2.5							SO 00021-18-3/4"		18
	2 x ALG142	VMP45.15-2.5									
	ALG152	ALG152B	VVP45.20-4	20	G1		Rp½	≈ 23	≈ 13		
	ALG153	ALG153B	VXP45.20-4								
	2 x ALG152	2 x ALG152B	VMP45.20-4								
	ALG202	ALG202B	VVP45.25-6.3	25	G1¼		Rp¾	≈ 25	≈ 15		
	ALG203	ALG203B	VXP45.25-6.3								
	ALG252	ALG252B	VVP45.25-10								
	ALG253	ALG253B	VXP45.25-10	32	G1½		Rp1	≈ 27	≈ 17		
	ALG322	ALG322B	VVP45.32-16								
	ALG323	ALG323B	VXP45.32-16	40	G2¼		Rp1¼	≈ 32	≈ 19		
	ALG402	ALG402B	VVP45.40-25								
	ALG403	ALG403B	VXP45.40-25								

¹⁾ Usable up to maximum medium temperature of 100 °C

²⁾ SO 00021-17.. and SO 00021-18 on request

- On valve side: cylindrical thread to ISO 228-1
- On pipe side: with cylindrical thread to ISO 7-1
- ALG..B for media temperatures up to 100 °C

Spare parts

Type	Stock No.	Description	Number
74 6760 273 0	74 6760 273 0	Manual knob for short stroke valves	10

Revision numbers

Type	Valid from rev. no.	Type	Valid from rev. no.	Type	Valid from rev. no.
VVP45.10-0.25	/01	VXP45.10-0.25	/01	VMP45.10-0.25	/01
VVP45.10-0.4	/01	VXP45.10-0.4	/01	VMP45.10-0.4	/01
VVP45.10-0.63	/01	VXP45.10-0.63	/01	VMP45.10-0.63	/01
VVP45.10-1	/01	VXP45.10-1	/01	VMP45.10-1	/01
VVP45.10-1.6	/01	VXP45.10-1.6	/01	VMP45.10-1.6	/01
VVP45.15-2.5	/01	VXP45.15-2.5	/01	VMP45.15-2.5	/01
VVP45.20-4	/01	VXP45.20-4	/01	VMP45.20-4	/01
VVP45.25-6.3	/01	VXP45.25-6.3	/01		
VVP45.25-10	/01	VXP45.25-10	/01		
VVP45.32-16	/01	VXP45.32-16	/01		
VVP45.40-25	/01	VXP45.40-25	/01		

Issued by
Siemens Switzerland Ltd
Building Technologies Division
International Headquarters
Gubelstrasse 22
6301 Zug
Switzerland
Tel. +41 41-724 24 24
www.siemens.com/buildingtechnologies

© Siemens Switzerland Ltd, 2011
Technical specifications and availability subject to change without notice.