



AlgoRex

Infrared flame detector

DF1101-Ex

for explosion-hazard areas of zones 1 and 2

- For inside and outside applications
- Triple-sensor evaluation:
 - Detection in various wavelengths
 - Microprocessor-controlled signal evaluation
- Selective evaluation of flicker frequency
- Selectable application algorithms
- Excellent immunity to false alarms thanks to a combination of patented fuzzy logic and Wavelet analysis
- Highest resistance to:
 - electromagnetic influence
 - sunlight and heat radiation
 - humidity and corrosion
- Wide operating temperature range
- Collective detector address
- Connection to the detection line via the DC1192 input/output module:
 - for galvanic isolation in collective fire detection systems
 - for galvanic isolation and connection to the interactive or AnalogPLUS fire detection system

Application

The DF1101-Ex infrared flame detector is suitable for the detection of smokeless combustible liquid and gas fires, as well as smoke-forming open fire involving carbonaceous materials as contained in wood, plastics, gases, oil products etc.

Fields of application

Chemicals production plants
 Chemicals stores
 Oil refineries
 Petrol storage and pump stations
 Natural gas transfer points
 Propane and butane filling installations
 All explosion-hazard areas in which flaming fires involving carbonaceous materials are to be expected

Operating principle

Patented signal evaluation

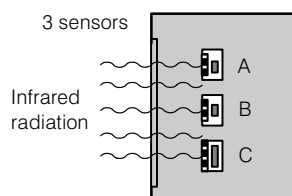
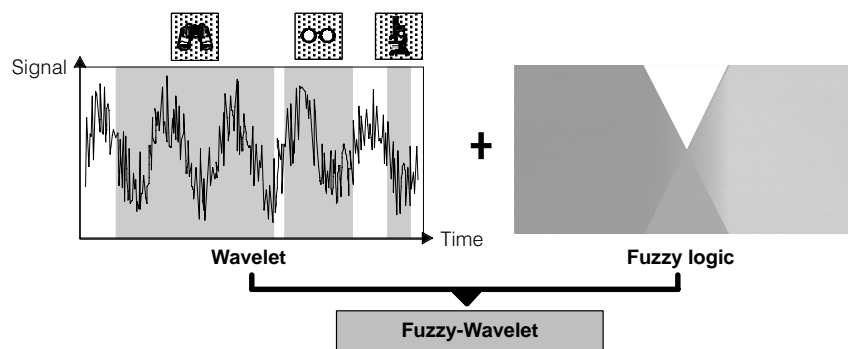

The detection elements of the infrared flame detector consist of two pyroelectric sensors and a silicon photo diode.

- Sensor A: The pyroelectric sensor A reacts to infrared flame gas in the characteristic CO₂ spectral range between 4.0 and 4.8µm.
- Sensor B: The pyroelectric B measures the infrared radiation of sources of interference in the range between 5.1 and 6µm.
- Sensor C: The silicon photo diode measures the solar radiation in the range between 0.7 and 1.1µm.

Triple-sensor evaluation

One sensor measures the hot carbon dioxide in a specific flame wavelength, the two other sensors simultaneously measure the interference radiation in other wavelengths.

Detection reliability

With intelligent signal processing through fuzzy algorithms and wavelet analysis, the DF1101-Ex achieves excellent detection reliability while maintaining the highest immunity to interference radiation and sunlight.

Emergency activation channel

In order to safeguard against a possible decision emergency, the detector contains an additional emergency activation channel.

Design

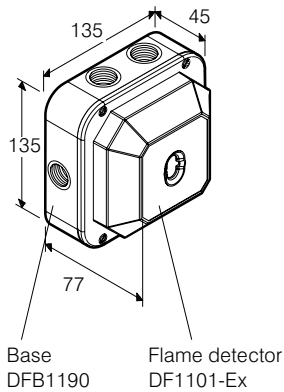

The two-component, enamelled aluminium housing contains the sensors, the encapsulated evaluating electronics and the programming switch and also shields the detector from electromagnetic interference (EMI).

The DFB1190 base comprises a robust, glassfibre-reinforced, plastic housing which provides the required isolated installation of the detector.

The base contains:

- screwless terminals
- chokes to protect against EMI
- plug attachment for the detector
- six M20x1.5 cable entry possibilities

The base is required when the wiring is being installed. The flame detector is inserted in the base shortly before commissioning.

The flame detector is connected by being plugged into the base.

Explosion protection category

The infrared flame detector DF1101-Ex is designed to the explosion protection category „Intrinsic safety” EEx i. The standards which cover this are EN50014 and EN50020.

Installation in explosion-hazard areas

Equipment installed in explosion-hazard areas must always comply with local national regulations.

The DC1192 input/output module and the series-connected SB3 shunt Zener diode barrier are used as a galvanic isolation between explosion-hazard and non-hazardous areas.

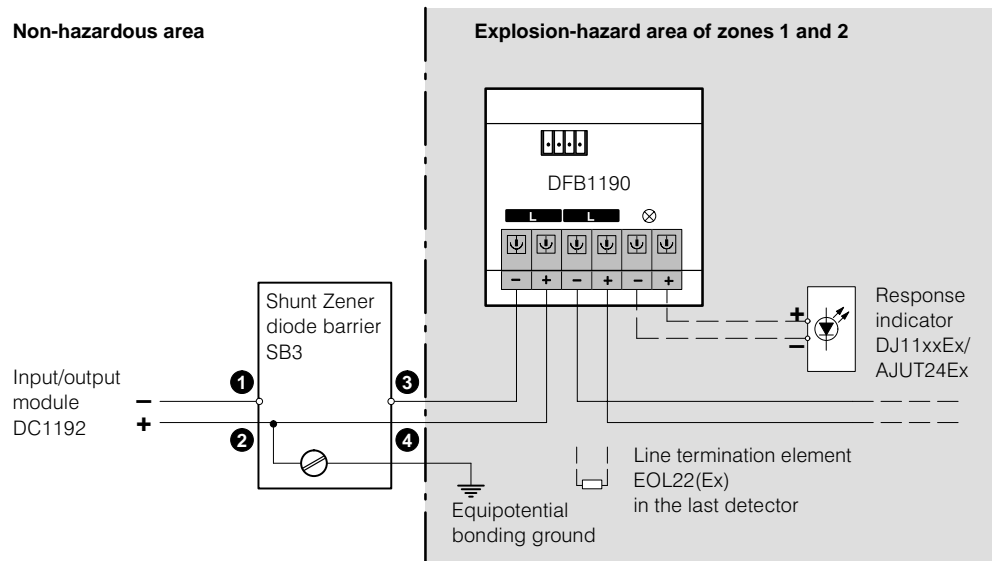

Further details

can be found in the documents:

- „Fire protection in explosion-hazard areas”, no. e1204 with current index
- „Input/output module DC1192”, no. e1571

Accessories

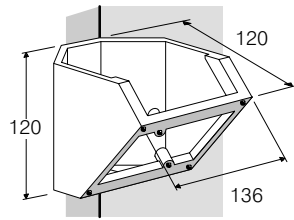

The MV1 mounting bracket is used to fix the flame detector at the correct angle.

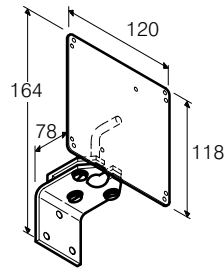

The MWV1 ball and socket joint is used to line up the flame detector with the object to be monitored.

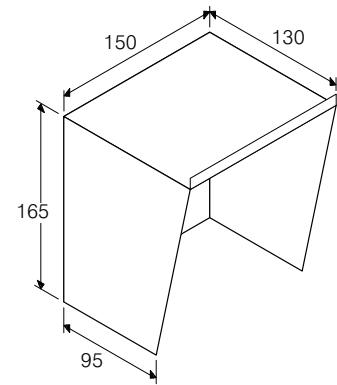

The DFZ1190 rain hood protects the detector in outside applications.

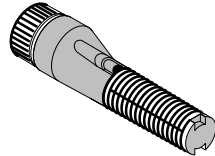

The Stabex HF test lamp is used to make a performance check on the flame detector. It must be held in front of the detector (see product data sheet Stabex HF, e252).

Technical data

Operating voltage	16 ... 28Vdc
Oper. current (quiescent)	0.5mA
Operating temperature	-35 ... +70°C
Storage temperature	-40 ... +75°C
Humidity	≤100%, no heavy condensation of window
Protection category (IEC60529)	IP67
Terminals	0.2 ... 2.5mm ² (AWG 24 ... 15)
Colour	pure white, ≈RAL9010
Connection factor	KMK 6
Standards	EN54-10, conforms with CE, IEC60079 / EN50020 for explosion-hazard areas
Ex classification	EEx ib IIC T4
Approvals	PTB 02 ATEX 2161 / VdS no. G299085 / LPCB 126s/03
Compatibility	By using the DC1192 input/output module it is compatible with fire detection system control units with collective, interactive or AnalogPLUS signal evaluation

Details for ordering

Type	Part no	Designation	Weight
DF1101-Ex	516675	Infrared flame detector	0.500kg
DFB1190	516536	Base	0.250kg
-	A5Q00004478	Screwed cable gland M20x1.5	0.035kg
DFZ1190	530266	Rain hood	0.640kg
MV1	395045	Mounting bracket	0.285kg
MWV1	367484	Ball and socket joint	0.860kg
Stabex HF	462091	Test lamp	0.250kg

