



QBM4000-..., QBM4100-1U



QBM4100-1D

Differential pressure sensor

QBM4000...
QBM4100...

For air and non-aggressive gases, with calibration certificate.

- Calibration certificate from the factory
- High degree of measuring accuracy
- Pressure-linear characteristic curve
- Operating voltage AC 24 V / DC 13.5...33 V or DC 11....33 V
- Output signal DC 0...10 V or 4...20 mA
- Simple and fast mounting thanks to integrated fixing angle bar in the housing
- Calibrated and temperature-compensated measuring signal
- Excellent long-term response
- Supplied with connection set
- Very short reaction time
- Display* indicates the present differential pressure

* Depending on type

Use

The differential pressure sensor acquires differential, over and under pressure of air and nonaggressive gases if a high degree of measuring accuracy and quality is required as well as a requirement for a calibration certificate.

Fields of application:

- Measuring slightest differential pressures in ventilation and air conditioning ducts
- Check air flows
- Monitor filters and control fans
- Pressure supervision in labs, production, storage and clean rooms
- For acquiring variable air flow in VAV plants on the supply and extract air side

Type summary

Type (ASN)	Product number (SSN)	Measuring range	Output signal	LCD indication
QBM4000-1	S55720-S247	0 ... 100 Pa	DC 0 ... 10 V	No
QBM4000-3	S55720-S248	0 ... 300 Pa	DC 0 ... 10 V	No
QBM4000-10	S55720-S249	0 ... 1000 Pa	DC 0 ... 10 V	No
QBM4000-25	S55720-S250	0 ... 2500 Pa	DC 0 ... 10 V	No
QBM4100-1U	S55720-S251	- 50 ... + 50 Pa	4 ... 20 mA	No
QBM4100-1D ¹	S55720-S252	0 ... 100 Pa	4 ... 20 mA	Yes

¹ Type with digital display.

Conversion 100 Pa = 1 hPa = 1 mbar

Ordering and delivery

When ordering a differential pressure sensor, please specify the quantity, type, and product name.

Example

Type (ASN)	Product number (SSN)	Product designation
QBM4000-1	S55720-S247	Differential pressure sensor with calibration certificate.

A round plug connector (Lumberg RKC 30/11) and a 2-meter PVC tube is included with the differential pressure sensor.

Additional accessories may be ordered separately.

Accessories

Additional sets of air duct probes are available depending on measuring requirements. Various mounting brackets are also available depending on installation location.

Type	Name	Data sheet
AQB2000	Mounting bracket, for mounting sensors in isolated air ducts.	N1590
AQB21.2	Top hat rail adapters (5 pieces) for DIN top hat rails, HT 35-7.5	N1590
FK-PZ1	Air duct probe, short, stainless steel, with elastic lead-through for simple, quick, and airtight mounting.	N1589
FK-PZ2	Air duct probe, long, aluminum, with orifice plates for precise measuring requirements.	N1589

Mode of operation

The sensor acquires the differential pressure using a silicon rubber membrane and ceramic bar. The sensor generates as per the deflection, a linear and temperature-compensated output signal DC 0...10 V or 4...20 mA.

Design

The differential pressure sensors consist of:

- Sensor housing with fixing angle bar, 3-pin plug and hinged lid with sealed safety screw
- Pressure chamber with membrane and ceramic lever
- Circuit board
- LCD display for the digital display of the sensor signal in Pa (for **QBM41...D** only)

Display, setting, and connection elements

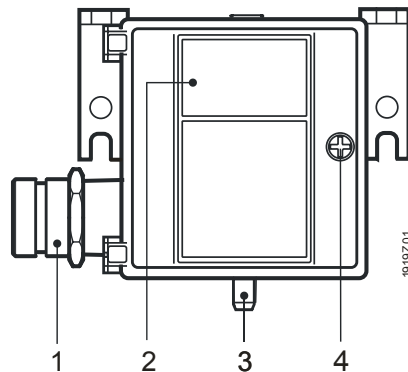

Key

- 1 3-pin plug
- 2 Display window (on **QBM4100-1D** only) for the digital display of the sensor signal
- 3 Connection nipples (see "Mounting notes")
- 4 Sealed safety screw for hinged cover

Mounting and installation notes

The differential pressure sensor is suited for direct mounting on air ducts, walls, ceilings, or in control panels.

The sensor must be installed vertically.

The supplied 2 meter plastic tubing can be modified to the duct connection on the plant.

To achieve the housing protective class indicated under "Technical data", the differential pressure sensors must be mounted with the pressure nipple facing down. In addition, they should be higher than the air duct probes.

Caution

If the pressure connection nipples point upward or are at a lower level than the air duct probes, condensation can collect inside the sensor, causing damage to the device.

Note

The pressure tubing for the sensor nipples are connected as following to the differential pressure sensors:

On the air duct side	On the pressure sensor side
Tubing with higher pressure side (lower vacuum)	Connect to pressure nipple "P1" or "+".
Tubing with lower pressure side (higher vacuum)	Connect to pressure nipple "P2" or "-".

The sensor is supplied with mounting instructions.
 Refer to the [Manual sensor installation](#) from the BT download center for additional information.

⚠ Caution

- Power supply by SELV or class 2 power supply with limited output of 15 W or less. (UL requirement)
- Use only copper wiring

Commissioning notes

⚠ Caution

The values indicated under "Technical data" apply only to vertically mounted differential pressure sensors (connection nipples pointing down).

Sensor calibration

The sensor is calibrated at the factor in the vertical position. As a consequence, the sensor must be **installed in the vertical position**. For horizontal installation (housing cover top or bottom), deviations occur to measured values that negate the measured values on the certificate.

Technical data

Electrical interface <i>QBM4000-...</i> 3-wire connection	Power supply	Safety extra low voltage (SELV/PELV)
	Operating voltage	AC 24 V ± 15 %, 50/60 Hz or DC 13.5...33
	Power consumption	< 0.5 VA
	Current draw	< 10 mA
	Output signal	DC 0...10 V, R _{Last} > 10 kΩ (not galvanically separated, 3-wire connection, short-circuit proof, protected against reverse polarity)
<i>QBM4000-...</i> 2-wire connection	Operating voltage	DC 8...33 V
	for ohm loads up to 500 Ω.	DC 18...33 V
	Power consumption	< 0.7 VA
	Current draw	4...20 mA
	Output signal	4...20 mA
		$R_{load} < \frac{\text{supply voltage} - 8 \text{ V} [\Omega]}{0,02 \text{ A}}$
		2-wire technology, short-circuit proof, protected against reverse polarity).

Product data	Measuring range	refer to "Type summary"
	Sensing element	Piezo-resistive (silicone membrane, ceramic bar)
	Degree of measuring accuracy at required installation position and room temperature 25 °C.	(FS = Full Scale)
QBM4100-1U	Sum from zero point, linearity, reproducible and hysteresis.	<±3 % FS (<±3 Pa)
	TC zero point	<±0,1 % FS/°C
	TC sensitivity	<±0,06 % FS/°C
QBM4000-1 QBM4100-1D	Zero point	<±1.0 % FS
	Sum from linearity, reproducible and hysteresis.	<±2 % FS
	TC zero point	<±0.1 % FS/°C
QBM4000-3 QBM4000-10 QBM4000-25	TC sensitivity	<±0.06 % FS/°C
	Zero point	<±0.7 % FS
	Sum from linearity, reproducible and hysteresis.	<±1 % FS
Degree of protection	TC zero point	<±0.05 % FS/°C
	TC sensitivity	<±0.05 % FS/°C
	Long-term stability	±1.0% FS as per DIN IEC 60 770
	Response time	<20 ms
	Load change	<10 Hz
	Tolerable overload on one side on P1.	5,000 Pa (10,000 Pa for types QBM4000 -10, -25)
	At P2	400 Pa
	Rupture pressure at room temperature	2 × overload
	at 70 °C	1.5 × overload
	Display (QBM4100-1D only)	LCD, 2-line, 8 position each, alphanumeric, not background lit ☐
	Display of:	Differential pressure in Pa.
	Media	Air and slightly aggressive gases
	Admissible medium temperature.	0...70 °C
Maintenance	Maintenance free	
Degree of protection	Degree of protection of housing at recommended installation	IP 54 as per IEC 60 529
	Protection class	III as per EN 60 730
Connections	Electrical connections	3-pin round plug with screw terminals 1.5 mm ² (Lumberg RKC 30/11)
	Pressure connections	PVC nipples Ø 6.2 mm, under pressure side is designated as 'P2' or ' - '.
Environmental conditions	Permissible ambient temperature	
	Operation	0...70 °C
	Transport and storage.	-25...+70 °C
	Permissible ambient humidity	<90 % r.h. (without condensation).

Directives, standards

CE conformity as per

EMC directive	2004/108/EC
Immunity, emissions.	EN 61 326-1, EN 61 326-2-3
RoHS directive	2011/65/EU
Technical RoHS documentation	EN 50 581
C -Conformity emissions	AS/NZS 61000-6-3.

cRU us

UL approval as per UL 60730-1 / UL 60730-2-6

Environmental compatibility

The product environmental declaration CE1E1916en contains data on environmentally compatible product design and assessments (RoHS compliance, materials composition, packaging, environmental benefit, disposal).

Dimensions (weight)

Weight (with packaging)	0.250 kg (with round plug connector).
Weight (with packaging), with display	0.263 kg (with round plug connector).

Connectors

QBM4000-..

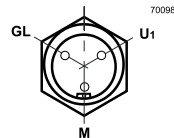

Front view of the plug on the sensor housing (internally wired at the factory) or the view of the connection side of the cable plug.



Terminal assignment

Operating voltage AC 24 V (SELV) or DC 13.5...33 V.

Output signal DC 0...10 V (reference point M)

GND

QBM4100-1.

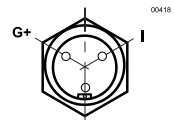

Front view of the plug on the sensor housing (internally wired at the factory) or the view of the connection side of the cable plug.

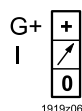

Terminal assignment

Supply voltage DC 8...33 V.

Output signal DC 4...20 mA.

Dimensions

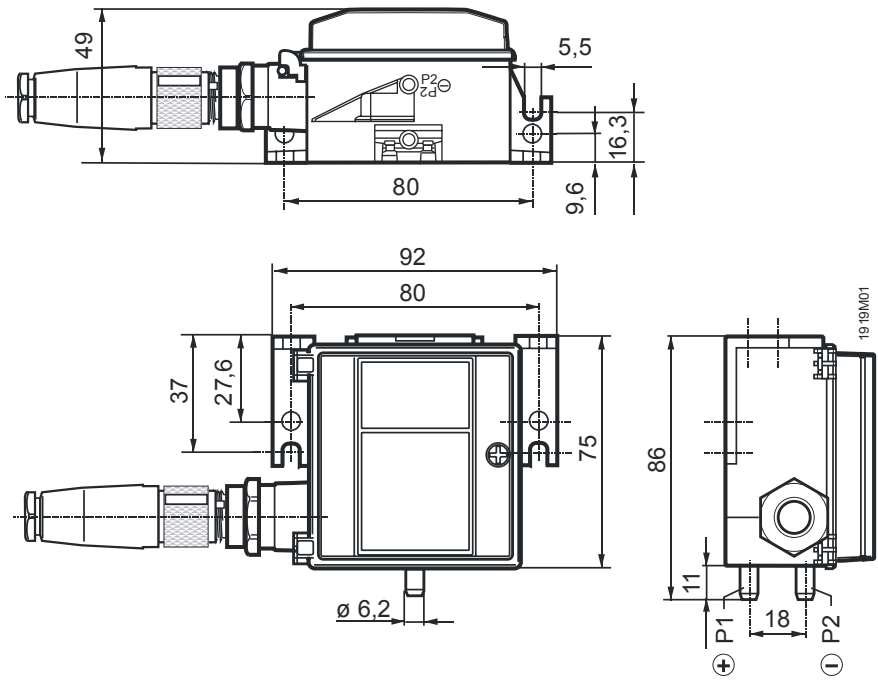

Dimensions in mm