

## VA Series

### VA... Valve Actuator Assemblies with VKG Butterfly Valves

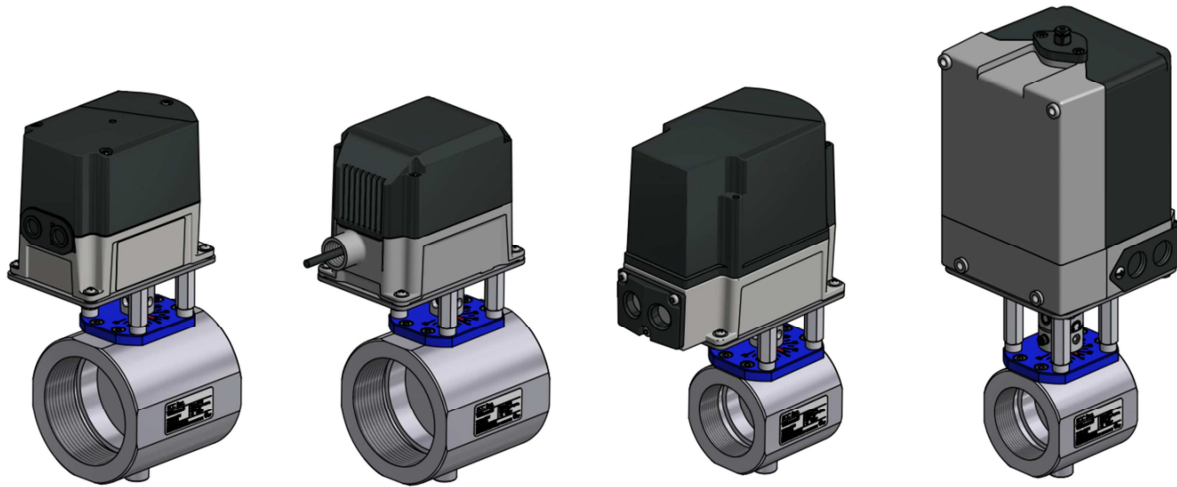

#### Description

VA... valve actuator assemblies include a Siemens SQM... actuator reliably mounted to a VKG... butterfly valve to control the flow of natural gas, propane, butane, or air.

#### Features

- Precision machined components enable the use of a solid shaft coupling
- Shaft coupling provides a positive connection between the valve and actuator without actuator or valve shaft damage
- Modular design enables field actuator clocking in 90° increments

#### Application

VA... valve actuator assemblies mount an SQM33, SQM40, SQM45, or SQM50 actuator to a VKG... butterfly valve. The VKG... valve and SQM... actuator are rigidly mounted with Siemens engineered brackets and couplings to ensure precise shaft alignment. VKG technical instructions (CVLV-2000) provide sizing and additional valve information.

## Product Part Numbers

The following chart provides VA... valve actuator assembly part number identification including an SQM33, SQM40, or SQM45 actuator. Technical instructions for SQM33 (N7813), SQM40 (N7817), or SQM45 (N7814) actuators are available at [www.scccombustion.com](http://www.scccombustion.com).

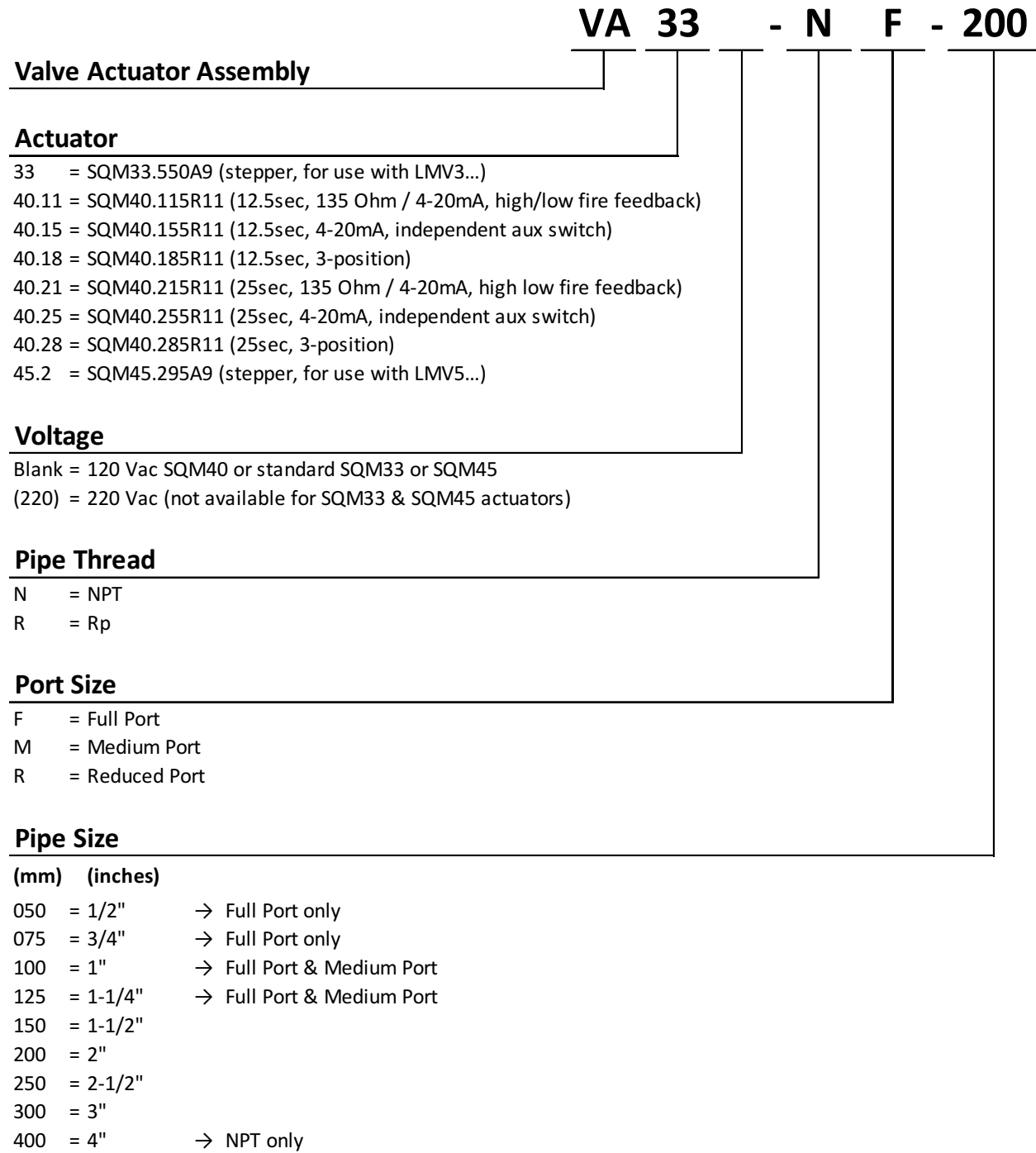

## Product Part Numbers (continued)

The following chart provides VA... valve actuator assembly part number identification including an SQM50 actuator. All VA... assemblies with an SQM5... actuator and a VKG... butterfly valve include the AGA55.5 NEMA 4 kit. Technical instructions for SQM50 (155-517) actuators are available at [www.scccombustion.com](http://www.scccombustion.com).

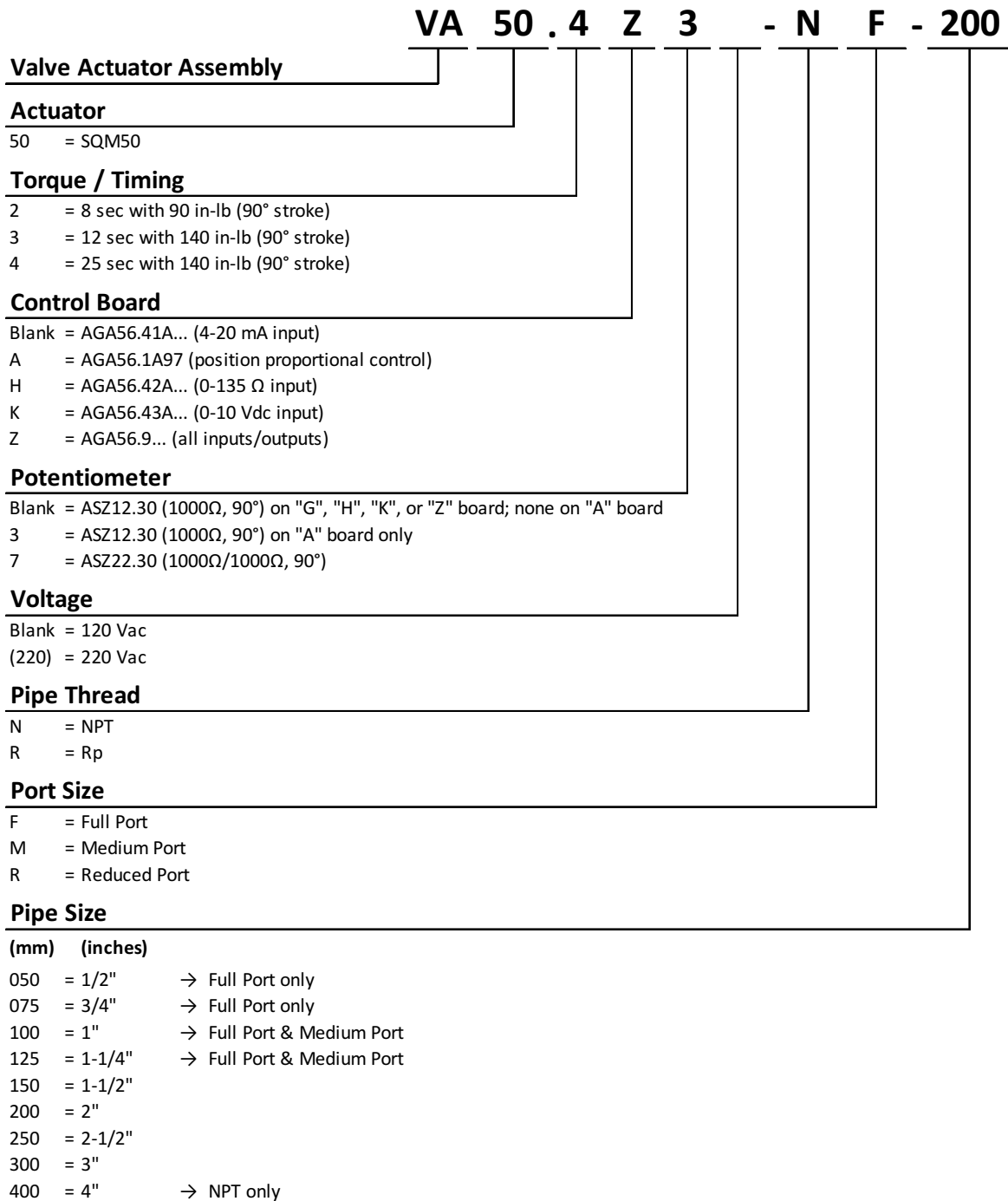

---

## Actuator Mounting Instructions

In some cases, the actuator may need to be removed from the valve temporarily during piping. Additionally, the actuator and bracket can be rotated relative to the valve for wiring purposes. The instructions below and the exploded views in Figures 1 and 2 are a guide to proper disassembly and reassembly of a VA... valve actuator assembly with a VKG... butterfly valve.

### SQM33/40/45 Actuators

#### Disassembly

1. Start with the valve at the closed / 0° position.
2. Remove the (4) #8 pan head screws (#2 phillips drive) and associated washers that fasten the actuator to the large bracket.
3. Loosen the (2) M4 socket cap screws (3mm hex drive) that fasten the small bracket to the coupling.
4. Pull back on the small bracket and lift the actuator off of the large bracket and out of the coupling.
5. Remove the (4) M6 flat head socket cap screws (4mm hex drive) from the large bracket and lift the bracket off of the 1/2" hex standoffs.
6. **If more clearance is needed for piping**, remove the (4) 1/2" hex standoffs using a crescent wrench. Also, remove the M4 socket cap screw (3mm hex drive) and lock washer fastening the coupling to the valve shaft, and lift the coupling off of the valve. **If the actuator is being rotated relative to the valve for wiring purposes**, remove the M4 socket cap screw (3mm hex drive) and lock washer fastening the coupling to the valve shaft, and lift the coupling off of the valve.

#### Reassembly

7. **If the (4) 1/2" hex standoffs were removed in step 6**, thread them back into the threaded holes on top of the valve and tighten with a crescent wrench. **If the coupling was removed in step 6**, slide the coupling back over the valve shaft. Insert the M4 socket cap screw and lock washer through the coupling and valve shaft so that the coupling is in the desired position of the (4) clockable positions. The valve should still be at the closed / 0° position.
8. Fasten the large bracket back onto the standoffs with the (4) M6 flat head socket cap screws (4mm hex drive) so that the overhanging section of the large bracket is on the opposite side of the coupling as the small bracket.
9. Insert a small flat head screwdriver into the keyhole (see Figure 1) between the thrust band, and with the other hand, grab the actuator and push it into the coupling until the actuator shaft clears the small bracket. Remove the screwdriver from the keyhole.
10. Press down on the actuator until it bottoms out on the large bracket.
11. Fasten the actuator to the large bracket with the (4) #8 pan head screws (#2 phillips drive) and associated washers. Then, tighten the (2) M4 socket cap screws (3mm hex drive) to secure the small bracket to the flat of the D-shaft.

## Actuator Mounting Instructions (continued)

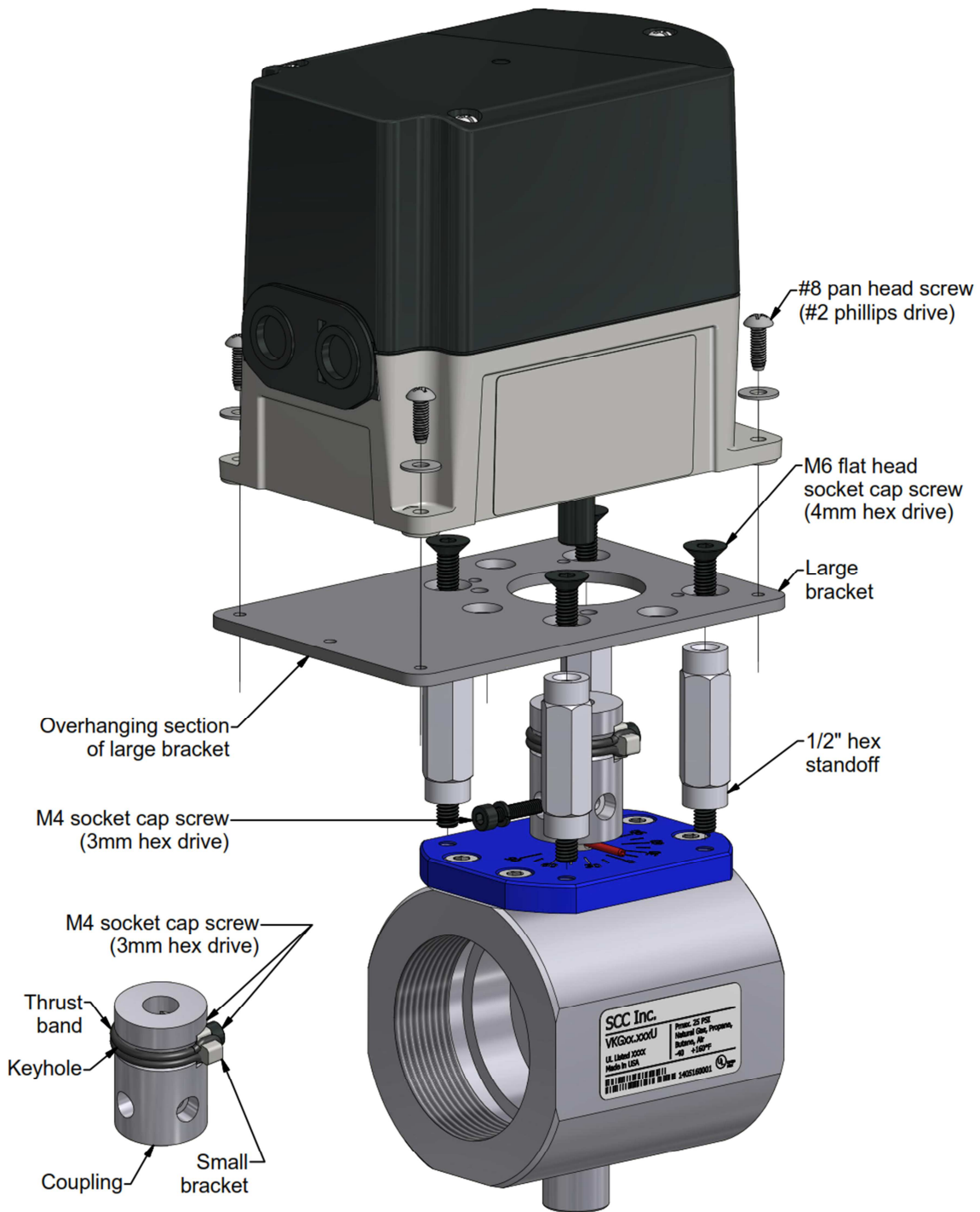

Figure 1: Exploded View of VA45.2-NF-200

---

## Actuator Mounting Instructions (continued)

### SQM50 Actuators

#### Disassembly

1. Start with the valve at the closed / 0° position.
2. Using a 10mm open end wrench (or crescent wrench), remove the (4) M6 hex head cap screws and lock washers that fasten the actuator to the bracket.
3. Loosen the #12 socket cap screw (5/32" hex drive) that clamps the actuator into the top hub of the coupling.
4. Pull the actuator off of the bracket and out of the coupling.
5. Remove the (4) M6 flat head socket cap screws (4mm hex drive) from the bracket and lift the bracket off of the 1/2" hex standoffs.
6. **If more clearance is needed for piping**, remove the (4) 1/2" hex standoffs using a crescent wrench. Also, remove the M4 socket cap screw (3mm hex drive) and lock washer fastening the coupling to the valve shaft, and lift the coupling off of the valve.

#### Reassembly

7. **If the (4) 1/2" hex standoffs were removed in step 6**, thread them back into the threaded holes on top of the valve and tighten with a crescent wrench.
8. Fasten the bracket back onto the standoffs with the (4) M6 flat head socket cap screws (4mm hex drive) in the desired position of the (4) clockable positions.
9. Using a 10mm open end wrench (or crescent wrench), fasten the actuator to the large bracket with the (4) M6 hex head cap screws and lock washers.
10. Tighten the #12 socket cap screw (5/32" hex drive) to clamp the top coupling hub around the actuator shaft.

## Actuator Mounting Instructions (continued)

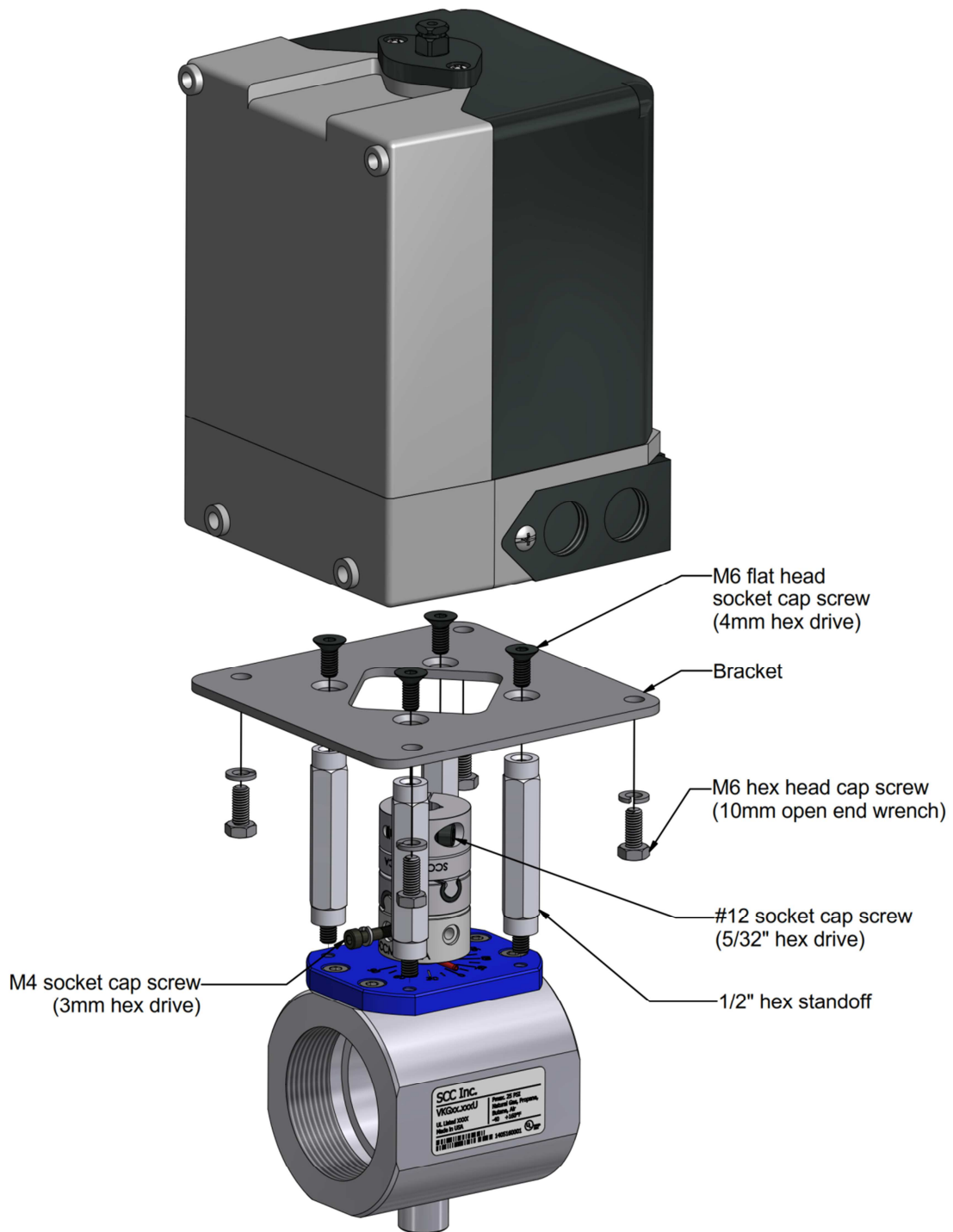
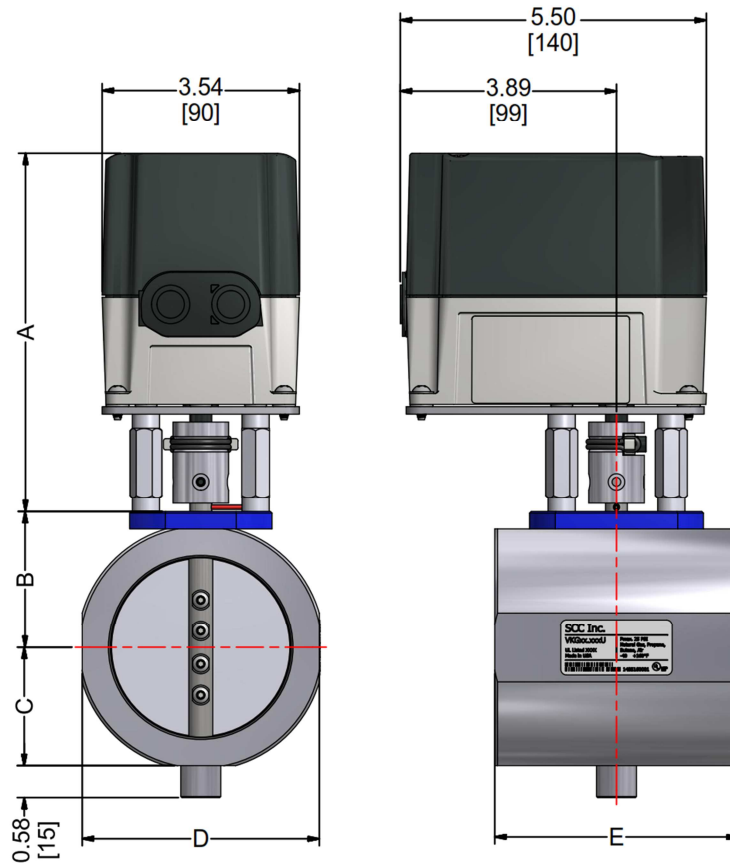

Figure 2: Exploded View of VA50.4-NF-200

## Dimensions

Dimensions in inches; millimeters in brackets



**Table 1: VA33..., VA40..., and VA45... Dimensions**

| Actuator | A          | Assembly Part Number Suffix | B         | C         | D          | E          |
|----------|------------|-----------------------------|-----------|-----------|------------|------------|
| SQM45... | 6.45 [164] | 050                         | 1.35 [34] | 1.04 [26] | 2.08 [53]  | 3.25 [83]  |
|          |            | 075                         | 1.35 [34] | 1.04 [26] | 2.08 [53]  | 3.25 [83]  |
|          |            | 100                         | 1.35 [34] | 1.04 [26] | 2.08 [53]  | 3.25 [83]  |
| SQM33... | 6.44 [164] | 125                         | 1.53 [39] | 1.22 [31] | 2.44 [62]  | 3.25 [83]  |
|          |            | 150                         | 1.63 [41] | 1.31 [33] | 2.63 [67]  | 3.25 [83]  |
|          |            | 200                         | 1.87 [47] | 1.55 [39] | 3.11 [79]  | 3.25 [83]  |
| SQM40... | 7.75 [197] | 250                         | 2.18 [55] | 1.87 [47] | 3.74 [95]  | 4.38 [111] |
|          |            | 300                         | 2.44 [62] | 2.13 [54] | 4.26 [108] | 4.38 [111] |
|          |            | 400                         | 2.96 [75] | 2.64 [67] | 5.28 [134] | 5.00 [127] |



## Dimensions (continued)

Dimensions in inches; millimeters in brackets

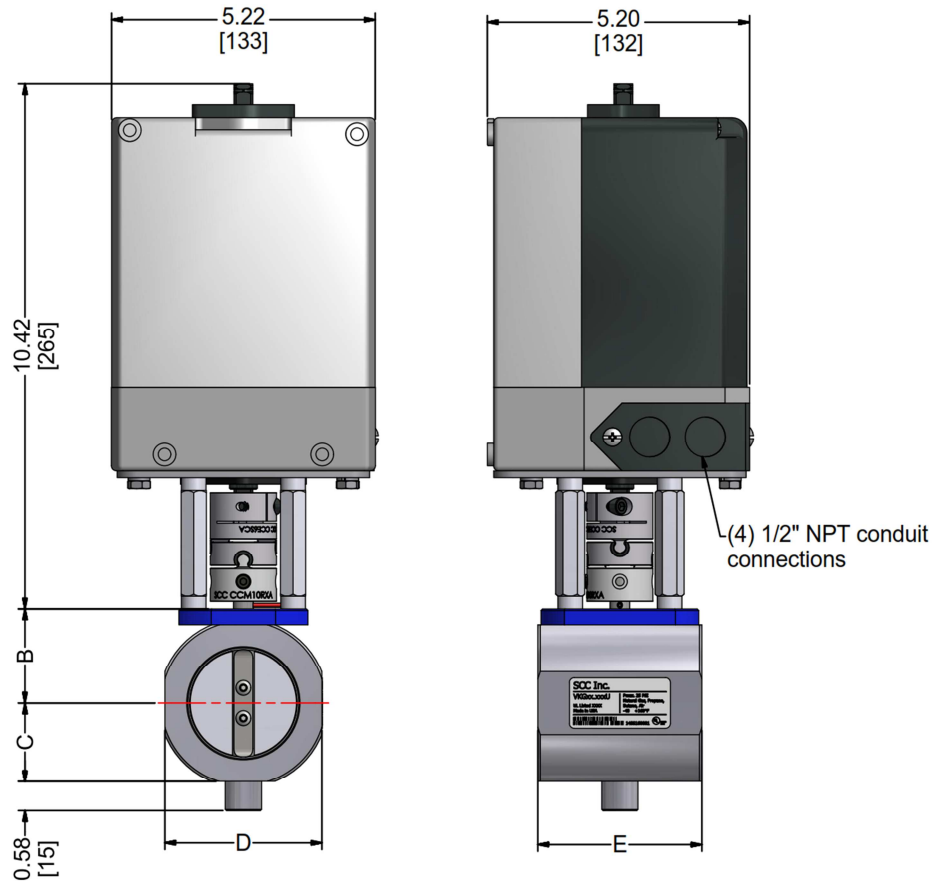

**Table 2: VA50... Dimensions**

| Assembly Part Number Suffix | B         | C         | D          | E          |
|-----------------------------|-----------|-----------|------------|------------|
| 050                         | 1.35 [34] | 1.04 [26] | 2.08 [53]  | 3.25 [83]  |
| 075                         | 1.35 [34] | 1.04 [26] | 2.08 [53]  | 3.25 [83]  |
| 100                         | 1.35 [34] | 1.04 [26] | 2.08 [53]  | 3.25 [83]  |
| 125                         | 1.53 [39] | 1.22 [31] | 2.44 [62]  | 3.25 [83]  |
| 150                         | 1.63 [41] | 1.31 [33] | 2.63 [67]  | 3.25 [83]  |
| 200                         | 1.87 [47] | 1.55 [39] | 3.11 [79]  | 3.25 [83]  |
| 250                         | 2.18 [55] | 1.87 [47] | 3.74 [95]  | 4.38 [111] |
| 300                         | 2.44 [62] | 2.13 [54] | 4.26 [108] | 4.38 [111] |
| 400                         | 2.96 [75] | 2.64 [67] | 5.28 [134] | 5.00 [127] |

Information in this publication is based on current specifications. The company reserves the right to make changes in specifications and models as design improvements are introduced. Product or company names mentioned herein may be the trademarks of their respective owners. © 2014 SCC Inc.