

Thermo. operated water valve Type AVTA



Thermo. operated water valves are used for proportional regulation of flow quantity, depending on the setting and the sensor temperature.

The Danfoss range of thermo. operated water valves includes a series of products for both refrigeration and heating regulation. The valves are self-acting, i.e. they operate without the supply of auxiliary energy such as electricity or compressed air.

The required temperature is maintained constant without unnecessary use of:

- cooling water in cooling systems,
 - hot water or steam in heating systems.
- The operating economy and efficiency are maximized.

AVTA SS for aggressive media.

A valve body in stainless steel means that the valve can be used for aggressive media in such applications as the marine sector and the chemical industry.

Features

- Insensitive to dirt
- Insensitive to water pressure
- Needs no power supply – self acting
- Opens on rising sensor temperature
- Differential pressure: 0 – 10 bar
- Maximum working pressure (PS): 16 bar
- Maximum test pressure: 25 bar
- Maximum pressure on sensor: 25 bar
- Stainless steel version available
- The valves are pressure-relieved, i.e. the degree of opening is not affected by differential pressure Δp (pressure drop).
- The regulation range is defined for the point at which the valve begins to open.
- Cooling media temperature range: -25 – 130 °C
- Ethylene glycol as a cooling media up to 40%

How it works

Thermo. operated water valves consist of three main elements:

1. Setting section with knob, reference spring and setting scale.
2. Valve body with orifice, closing cone and sealing elements.
3. Hermetically sealed thermostatic element with sensor, bellows and charge.

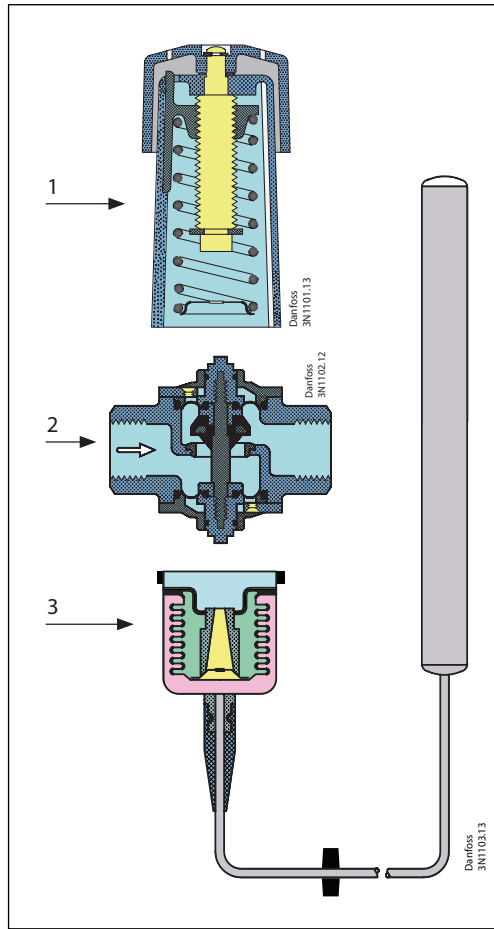

When the three elements have been assembled together, the valve installed and the sensor located at the point where the temperature is to be regulated, the function sequence is as follows:

1. The pressure changes in the sensor as a result of a change in temperature - builds up in the sensor.
2. This pressure is transferred to the valve via the capillary tube and bellows and acts as an opening or closing force.
3. The knob on the setting section and the spring exert a force that acts counter to the bellows.
4. When balance is created between the two opposing forces, the valve spindle remains in its position.
5. If the sensor temperature changes – or if the settings are changed – the point of balance becomes displaced and the valve spindle moves until balance is re-established, or the valve is fully open or closed.
6. The flow quantity change is approximately proportional to sensor temperature change.

The illustrations show an AVTA cooling water valve, but the function principle applies to all types of thermostatic valves.

AVTA applications



AVTA thermo. operated water valves are widely used for temperature regulation in many different machines and installations where cooling is required. AVTA cooling water valves always open to admit flow on rising sensor temperature.

The valve can be installed in either the cooling water flow line or the return line.

The standard version of the AVTA thermo. operated water valve can be used with fresh water or neutral brine.

Typical application areas:

- Injection moulding machines
- Compressors
- Vacuum pumps
- Dry cleaning machines
- Distillation plants
- Printing machines
- Hydraulic systems
- Roller mills
- Biomass boilers
- Industrial lasers
- Steam sterilizers
- Medical equipment
- Food processing

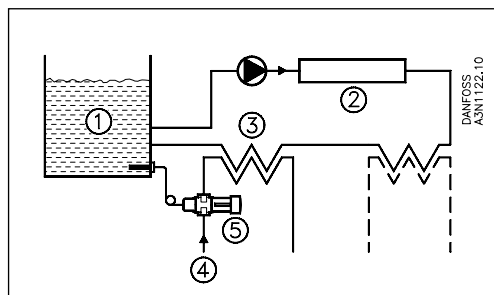

1. Oil tank
2. Hydraulic machinery
3. Heat exchangers
4. Cooling water supply
5. AVTA thermostatic valve

Materials

AVTA

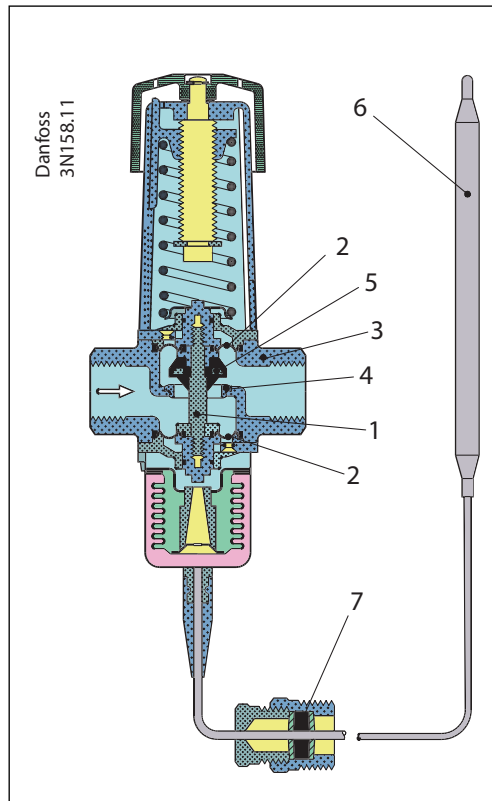

| No. | Description | Material AVTA | Material AVTA SS |
|-----|----------------------------------|---------------------------------------|------------------|
| 1 | Spindle | Brass | Stainless steel |
| 2 | Diaphragms | Rubber – ethylene – propylene (EPDM). | |
| 3 | Valve body and other metal parts | Forged brass | Stainless steel |
| 4 | Valve seat | Stainless steel | |
| 5 | Valve cone | Nitrile rubber (NBR) | |
| 6 | Sensor | Copper | |
| 7 | Capillary tube gland | Nitrile rubber (NBR) / brass | |

Charges

AVTA thermo. operated water valves with different types of charge



Ordering AVTA with adsorption charge

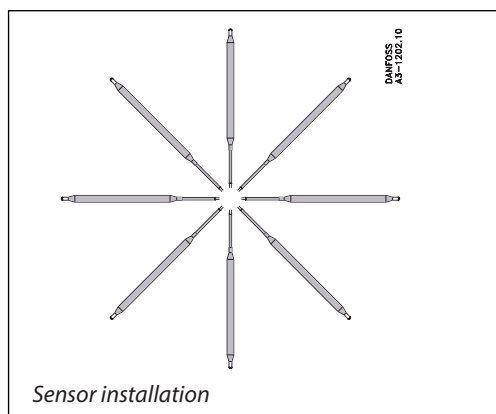

The charge consists of active carbon and CO₂ which is adsorbed on falling sensor temperature, thereby producing a pressure change in the element.

- Wide regulating range
- Can be installed in any position as far as orientation and temperature are concerned
- Small sensor dimensions – $\varnothing 9.5 \times 150$ mm
- Max. pressure on sensor 25 bar

| Connection ¹⁾ | Regulating range | Max. temp. sensor | kv value | Capillary tube length | Type | Code no. ²⁾ |
|--------------------------|------------------|-------------------|---|-----------------------|---------|------------------------|
| | [°C] | [°C] | (m ³ /h at $\Delta p = 1$ bar) | [m] | | |
| G $\frac{3}{8}$ | 10 – 80 | 130 | 1.4 | 2.3 | AVTA 10 | 003N1144 |
| G $\frac{1}{2}$ | 10 – 80 | 130 | 1.9 | 2.3 | AVTA 15 | 003N0107 |
| G $\frac{1}{2}$ | 10 – 80 | 130 | 1.9 | 2.3 (armoured) | AVTA 15 | 003N2114 |
| G $\frac{3}{4}$ | 10 – 80 | 130 | 3.4 | 2.3 | AVTA 20 | 003N0108 |
| G 1 | 10 – 80 | 130 | 5.5 | 2.3 | AVTA 25 | 003N0109 |

For immersion pockets, see "Spare parts and accessories", page 10.

¹⁾ ISO 228-1

²⁾ Code no. covers complete valve incl. capillary tube gland.

Ordering AVTA with universal charge

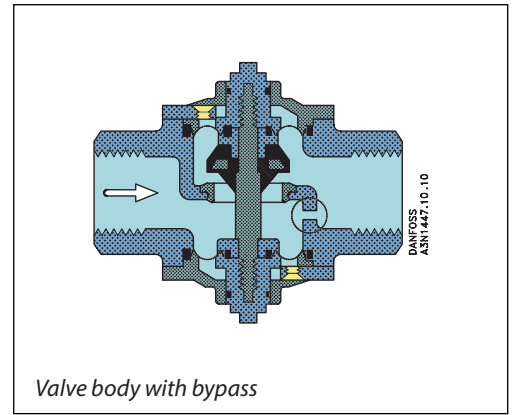
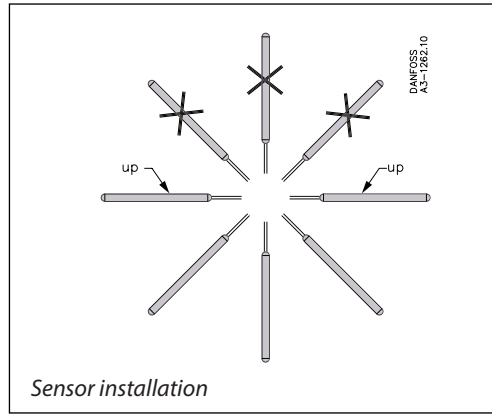

The charge is a mix of liquid and gas where the liquid surface (regulating point) is always inside the sensor. Which charge medium is used depends on the regulation range.

- Sensor dimensions $\varnothing 18 \times 210$ mm
- Sensor can be installed in a place where it is either colder or warmer than the valve
- Sensors must be orientated as shown in the sketch below
- Max. pressure on sensor 25 bar

| Connection ¹⁾ | Regulating range | Max. temp. sensor | kv value | Capillary tube length | Type | Code no. ²⁾ |
|--------------------------|------------------|-------------------|---|-----------------------|---------|-------------------------------|
| | [°C] | [°C] | (m ³ /h at $\Delta p = 1$ bar) | [m] | | |
| G $\frac{3}{8}$ | 0 – 30 | 57 | 1.4 | 2.0 | AVTA 10 | 003N1132 |
| G $\frac{1}{2}$ | 0 – 30 | 57 | 1.9 | 2.0 | AVTA 15 | 003N2132 |
| G $\frac{3}{4}$ | 0 – 30 | 57 | 3.4 | 2.0 | AVTA 20 | 003N3132 |
| G 1 | 0 – 30 | 57 | 5.5 | 2.0 | AVTA 25 | 003N4132 |
| G $\frac{3}{8}$ | 25 – 65 | 90 | 1.4 | 2.0 | AVTA 10 | 003N1162 |
| G $\frac{1}{2}$ | 25 – 65 | 90 | 1.9 | 2.0 | AVTA 15 | 003N2162 |
| G $\frac{1}{2}$ | 25 – 65 | 90 | 1.9 | 2.0 (armoured) | AVTA 15 | 003N0041 |
| G $\frac{3}{4}$ | 25 – 65 | 90 | 3.4 | 2.0 | AVTA 20 | 003N3162 |
| G $\frac{3}{4}$ | 25 – 65 | 90 | 3.4 | 5.0 | AVTA 20 | 003N3165 |
| G $\frac{3}{4}$ | 25 – 65 | 90 | 3.4 | 2.0 (armoured) | AVTA 20 | 003N0031 |
| G 1 | 25 – 65 | 90 | 5.5 | 2.0 | AVTA 25 | 003N4162 |
| G 1 | 25 – 65 | 90 | 5.5 | 2.0 (armoured) | AVTA 25 | 003N0032 |
| G 1 | 25 – 65 | 90 | 5.5 | 5.0 | AVTA 25 | 003N4165 |
| G $\frac{3}{8}$ | 50 – 90 | 125 | 1.4 | 2.0 | AVTA 10 | 003N1182 |
| G $\frac{1}{2}$ | 50 – 90 | 125 | 1.9 | 2.0 | AVTA 15 | 003N2182 |
| G $\frac{3}{4}$ | 50 – 90 | 125 | 3.4 | 2.0 | AVTA 20 | 003N3182 |
| G 1 | 50 – 90 | 125 | 5.5 | 2.0 | AVTA 25 | 003N4182 |
| G 1 | 50 – 90 | 125 | 5.5 | 3.0 | AVTA 25 | 003N4183 ³⁾ |

For immersion pockets, see "Spare parts and accessories", page 10.

¹⁾ ISO 228-1

²⁾ Code no. covers complete valve incl. capillary tube gland.

³⁾ A $\varnothing 2$ mm bypass is drilled in the valve body.

Ordering AVTA with mass charge

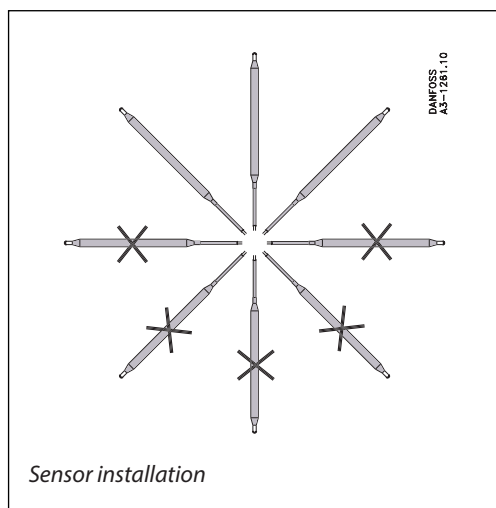

The charge is a mix of liquid and gas. Due to the mixture of liquid and gas the sensor must be installed in an area or environment that is warmer than the valve.

- Small sensor dimensions – $\varnothing 9.5 \times 180$ mm
- Short time constant
- Max. pressure on sensor 25 bar

| Connection ¹⁾ | Regulating range [°C] | Max. temp. sensor [°C] | kv value (m ³ /h at $\Delta p = 1$ bar) | Capillary tube length [m] | Type | Code no. ²⁾ |
|--------------------------|--------------------------|---------------------------|---|------------------------------|---------|------------------------|
| G 1/2 | 0 – 30 | 57 | 1.9 | 2.0 | AVTA 15 | 003N0042 |
| G 3/4 | 0 – 30 | 57 | 3.4 | 2.0 | AVTA 20 | 003N0043 |
| G 1/2 | 25 – 65 | 90 | 1.9 | 2.0 | AVTA 15 | 003N0045 |
| G 1/2 | 25 – 65 | 90 | 1.9 | 2.0 (armoured) | AVTA 15 | 003N0299 |
| G 1/2 | 25 – 65 | 90 | 1.9 | 5.0 | AVTA 15 | 003N0034 |
| G 3/4 | 25 – 65 | 90 | 3.4 | 2.0 | AVTA 20 | 003N0046 |
| G 1 | 25 – 65 | 90 | 5.5 | 2.0 | AVTA 25 | 003N0047 |

¹⁾ ISO 228-1

²⁾ Code no. covers complete valve incl. capillary tube gland.

Ordering AVTA in Stainless Steel with adsorption charge

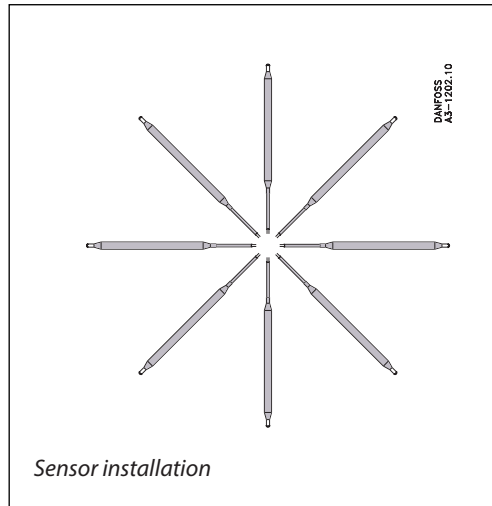

- Wide regulating range
- Can be installed in any position as far as orientation and temperature are concerned
- Small sensor dimensions – $\varnothing 9.5 \times 150$ mm
- Max. pressure on sensor 25 bar
- AVTA SS mass and universal charges available on request

| Connection ¹⁾ | Regulating range [°C] | Max. temp. sensor [°C] | k_v value (m ³ /h at $\Delta p = 1$ bar) | Capillary tube length [m] | Type | Code no. ²⁾ |
|--------------------------|-----------------------|------------------------|---|---------------------------|---------|------------------------|
| G 1/2 | 10 – 80 | 130 | 1.9 | 2.3 | AVTA 15 | 003N2150 |
| G 3/4 | 10 – 80 | 130 | 3.4 | 2.3 | AVTA 20 | 003N3150 |
| G 1 | 10 – 80 | 130 | 5.5 | 2.3 | AVTA 25 | 003N4150 |

For immersion pockets, see “Spare parts and accessories”, page 10.

¹⁾ ISO 228-1

²⁾ Code no. covers complete valve incl. capillary tube gland.

Dimensions [mm] and weights [kg] of AVTA valves in brass and stainless steel housings

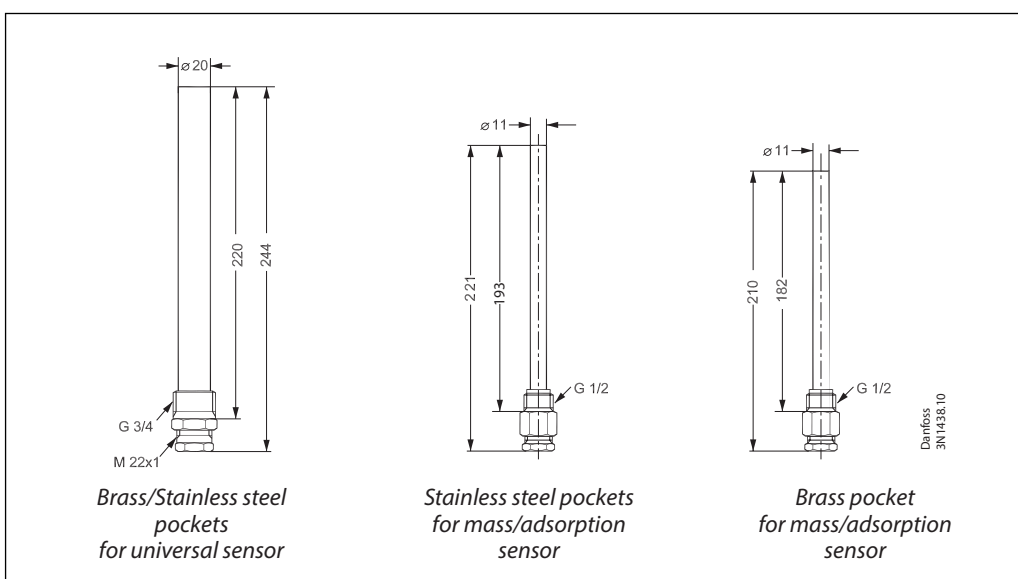
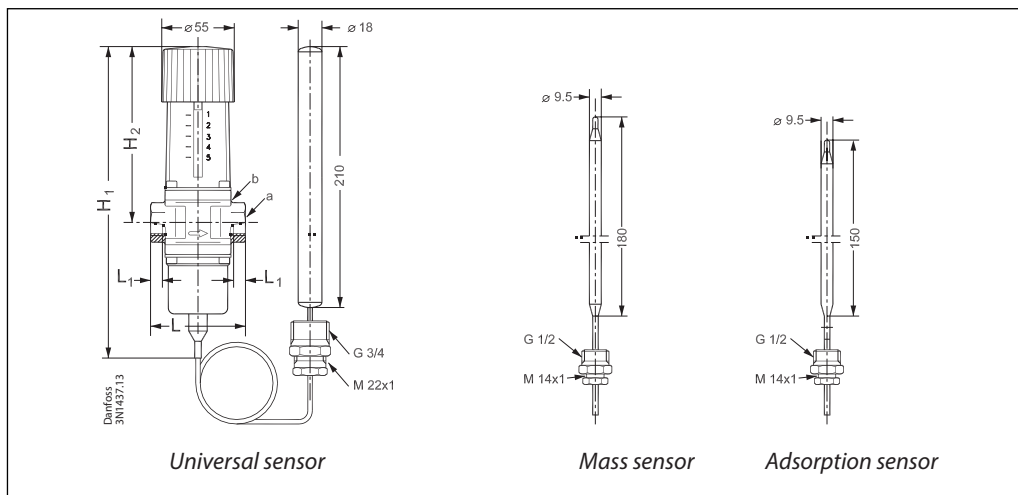

| Type | H ₁ | H ₂ | L | L ₁ | a | b | Net weight |
|---------|----------------|----------------|----|----------------|-------|-----|------------|
| AVTA 10 | 240 | 133 | 72 | 14 | G 3/8 | ○27 | 1.45 |
| AVTA 15 | 240 | 133 | 72 | 14 | G 1/2 | ○27 | 1.45 |
| AVTA 20 | 240 | 133 | 90 | 16 | G 3/4 | ○32 | 1.50 |
| AVTA 25 | 240 | 138 | 95 | 19 | G 1 | ○41 | 1.65 |

Installation

AVTA with mounting bracket

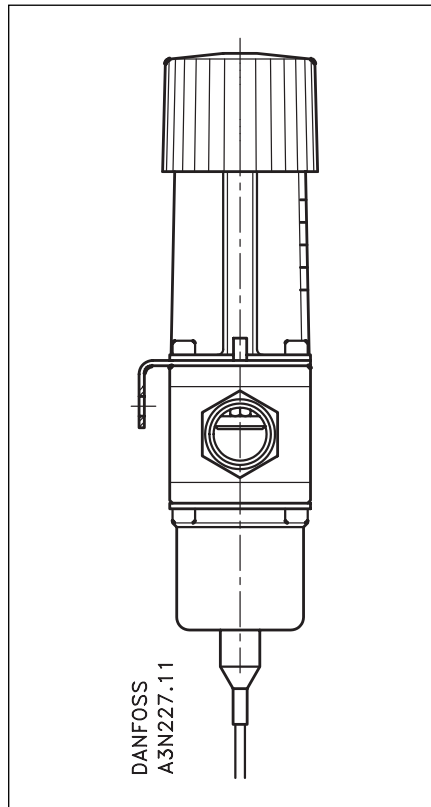

The valves can be installed in any position. An arrow on the valve body indicates the direction of flow.

AVTA valves are marked so that the letters RA are the right way up when the valve is held as shown. The installation of an FV filter ahead of the valve is recommended.



Capillary tube

Install the capillary tube without sharp bends (no "kinks"). Make sure that there is no strain on the capillary tube at the ends. Relief is important where vibration might occur.

Note:

When an AVTA valve is used, the sensor must be able to react to variations in cooling water temperature on system start. Therefore a bypass line with a shut-off valve might be necessary to ensure flow at the sensor during start-up. If a mounting bracket is used – see "Spare parts and accessories", page 10 – it must always be positioned between the valve body and the setting section (see illustration).

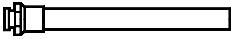
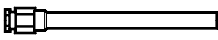
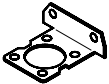
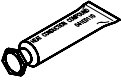
Accessories

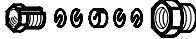
| | Designation | Description | Code no. |
|---|--|--|-------------------|
|  | Immersion sensor max. pressure 50 bar L = 220 mm | Brass for $\varnothing 18$ sensor G $\frac{3}{4}$ | 003N0050 |
| | | Brass for $\varnothing 18$ mm, sensor $\frac{3}{4}$ – 14 NPT | 003N0051 |
| | | 18/8 steel ¹⁾ for $\varnothing 18$ sensor, $\frac{3}{4}$ – 14 NPT | 003N0053 |
| | | 18/8 steel ¹⁾ for $\varnothing 18$ sensor R $\frac{3}{4}$ | 003N0192 |
|  | Immersion sensor max. pressure 50 bar L = 182 mm | Brass for $\varnothing 9.5$ sensor G $\frac{1}{2}$ | 017-436766 |
| | | 18/8 steel ¹⁾ for $\varnothing 9.5$ sensor R $\frac{1}{2}$ | 003N0196 |
|  | Mounting bracket | For AVTA | 003N0388 |
|  | Heat-conductive compound | 5 gram tube | 041E0110 |
| | | 0.8 kg | 041E0111 |
|  | Set of 3 nitrile (NBR) diaphragms sets for mineral oil | For AVTA 10/15, 20, 25 | 003N0448 |
|  | Capillary tube gland | G $\frac{1}{2}$ | 017-422066 |
| | | G $\frac{3}{4}$ | 003N0155 |
| | | $\frac{1}{2}$ – 14 NPT | 003N0157 |
| | | $\frac{3}{4}$ – 14 NPT | 003N0056 |
| | Plastic hand knob | For AVTA | 003N0520 |

¹⁾W. no. 1.4301

Spare parts

Thermostatic elements for AVTA valves

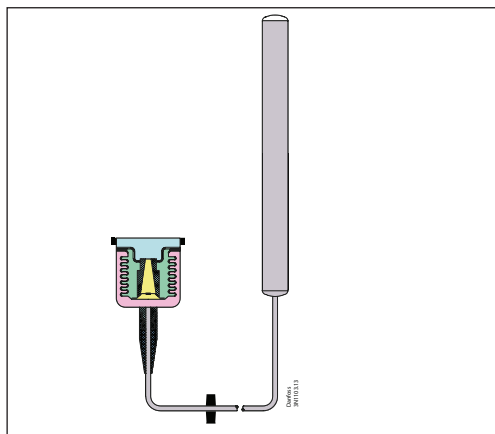

| Thermostatic Elements | Temperature range [°C] | Capillary tube length [m] | Code no. |
|--|---------------------------|------------------------------|-----------------|
| Adsorption charge – sensor $\varnothing 9.5 \times 150$ mm | 10 – 80 | 2.3 | 003N0278 |
| Universal charge – sensor $\varnothing 18 \times 210$ mm | 0 – 30 | 2 | 003N0075 |
| | 0 – 30 | 5 | 003N0077 |
| | 25 – 65 | 2 | 003N0078 |
| | 25 – 65 | 5 | 003N0080 |
| | 50 – 90 | 2 | 003N0062 |
| Mass charge – sensor $\varnothing 9.5 \times 180$ mm | 25 – 65 | 2 | 003N0091 |
| | 25 – 65 | 5 | 003N0068 |

Sizing

When sizing and selecting thermo. operated water valves, it is most important to ensure that the valve is able to give the necessary quantity of cooling water at any time, irrespective of the load. Therefore, to select a suitable size of valve it is necessary to know the precise amount of cooling required. On the other hand, to avoid the risk of unstable regulation (hunting), the valve should not be oversized.

The type of charge must be selected on the basis of the temperature to be maintained, and on an assessment of the characteristics of each type, as described in the foregoing.

In general the aim should be to select the smallest valve capable of giving the required flow.

It is also recommended that the temperature range be chosen so that the required sensor temperature lies in the middle of the regulation range.

To help fine-setting the valve, a thermometer should be installed near the sensor.

Valve size

The following data are used when selecting the valve size:

- Required cooling water flow, Q [m³/h]
- Temperature rise in cooling water, Δt [°C]
- Differential pressure across valve, Δp [bar].

With fully open valve, the differential pressure should be around 50% of the total pressure drop across the cooling system.

The charts on page 12 are intended to make valve sizing easier.

Fig. 1 – Relation between heat quantity [kW] and cooling water quantity

Fig. 2 – Graphs of k_v values

Fig. 3 – Valve operating range

Fig. 4 – Flow quantities as a function of pressure drop Δp

Example

A cooling water valve must be selected for the temperature regulation of a vacuum pump.

Since direct regulation of the oil temperature is required, an AVTA valve is suitable. The sensor position is horizontal – and small dimensions are desired.

Given data:

- Necessary cooling at full load 10 kW.
- Oil temperature to be maintained constant at 45 °C
- Cooling water $p_1 = 3$ bar
- Outlet $p_3 = 0$ bar
- $p_2 = \frac{p_1 + p_3}{2}$ (guess)
- Cooling water temperature $t_1 = 20$ °C
- Outlet temperature $t_2 = 30$ °C

1. The graphs in **fig. 1** can be used to find the necessary cooling water quantity at $\Delta t = 10$ °C (30 °C – 20 °C) to 0.85 m³/h.

The graphs in **fig. 2** show the necessary k_v value for 0.85 m³/h with $\Delta p = p_1 - p_2 = 3 - 1.5 = 1.5$ bar for 0.7 m³/h.

The columns in **fig. 3** show that all four AVTA valves can be used, but in practice an AVTA 10 or 15 shall be selected, so the necessary water flow is in the middle of the regulating range.

The above considerations apply to both AVTA and FJVA types.

Operating conditions and other product requirements in this example mean that a valve with adsorption charge is the correct choice. The temperature range 10 °C – 80 °C is in order.

The table at the bottom of page 6 shows AVTA 10, code no. 003N1144, or AVTA 15, code no. 003N0107. Both fulfil the requirements named.

In many applications, installation conditions make the use of sensor pockets advisable.

“Accessories” on page 10 gives the code nos. for sensor pockets for $\varnothing 9.5$ mm sensors in brass and stainless steel: 017-436766 and 003N0196, respectively.

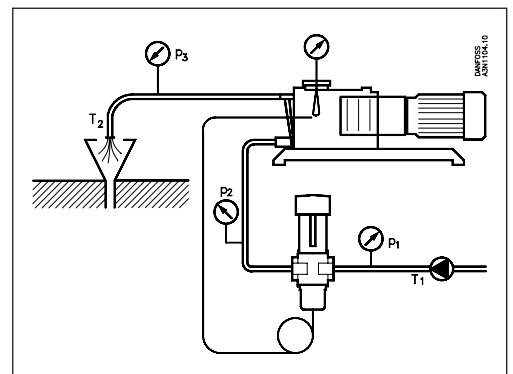

Sizing
(continued)

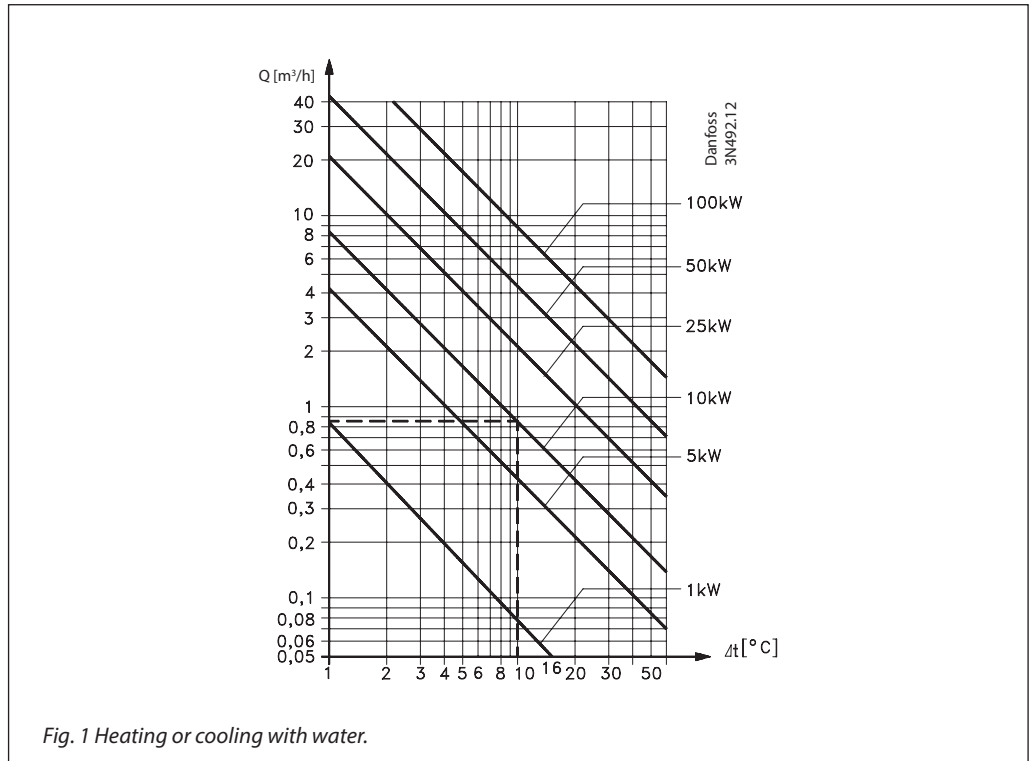

Example:
Necessary cooling output 10 kW with $\Delta t = 10\text{ }^\circ\text{C}$
Required flow $0.85\text{ m}^3/\text{h}$.

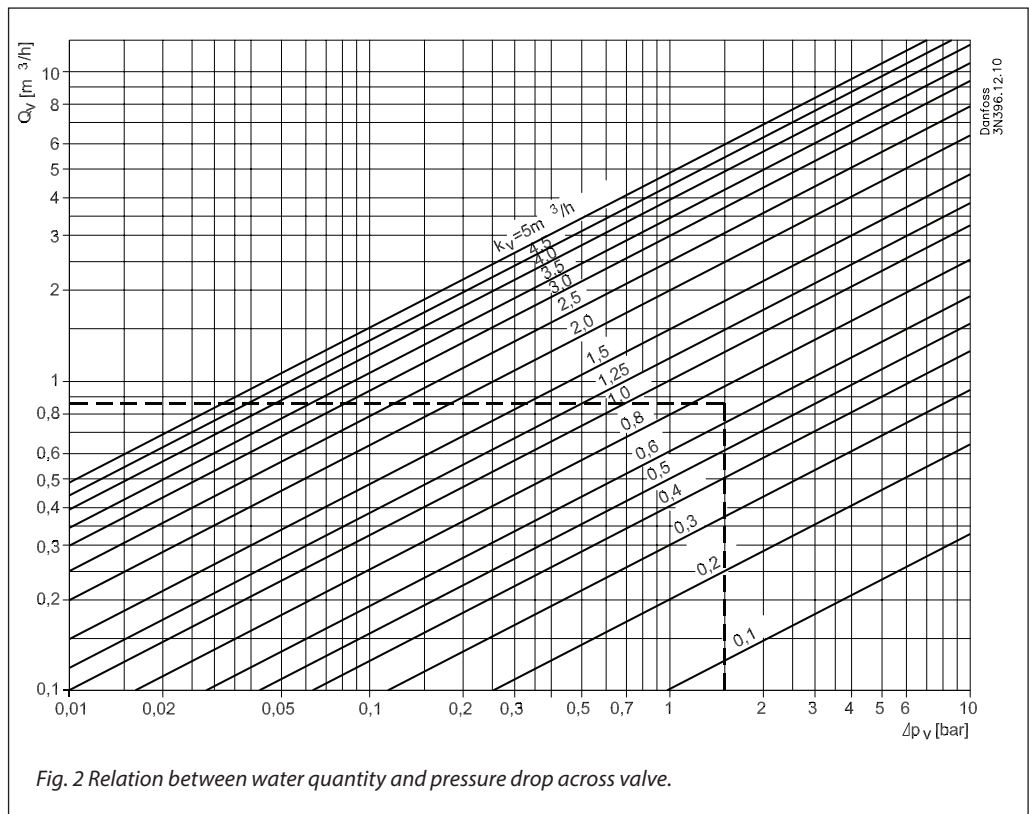

Example:
Flow $0.85\text{ m}^3/\text{h}$ with a pressure drop of 1.5 bar.
The k_v value becomes $0.7\text{ m}^3/\text{h}$.

Sizing

(continued)

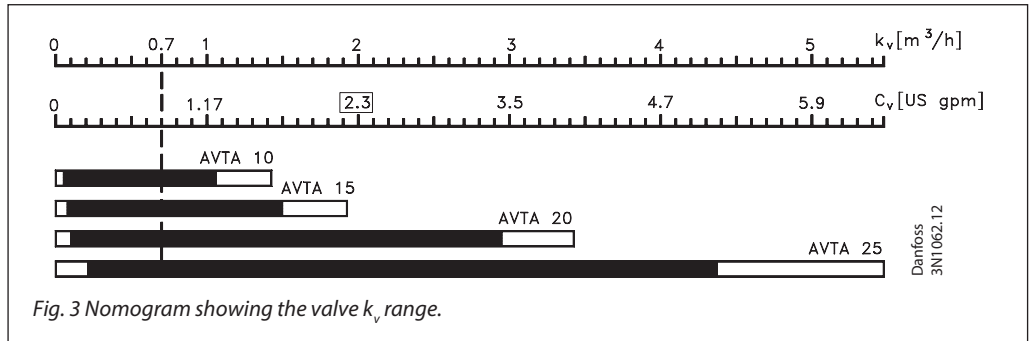

K_v values are always given for water flow in $[m^3/h]$ with a pressure drop Δp of 1 bar. The valve should be selected so that the necessary k_v value lies in the middle of the regulation range.

Example:

AVTA 10 and 15 are the most suitable for a k_v value of 0.7.

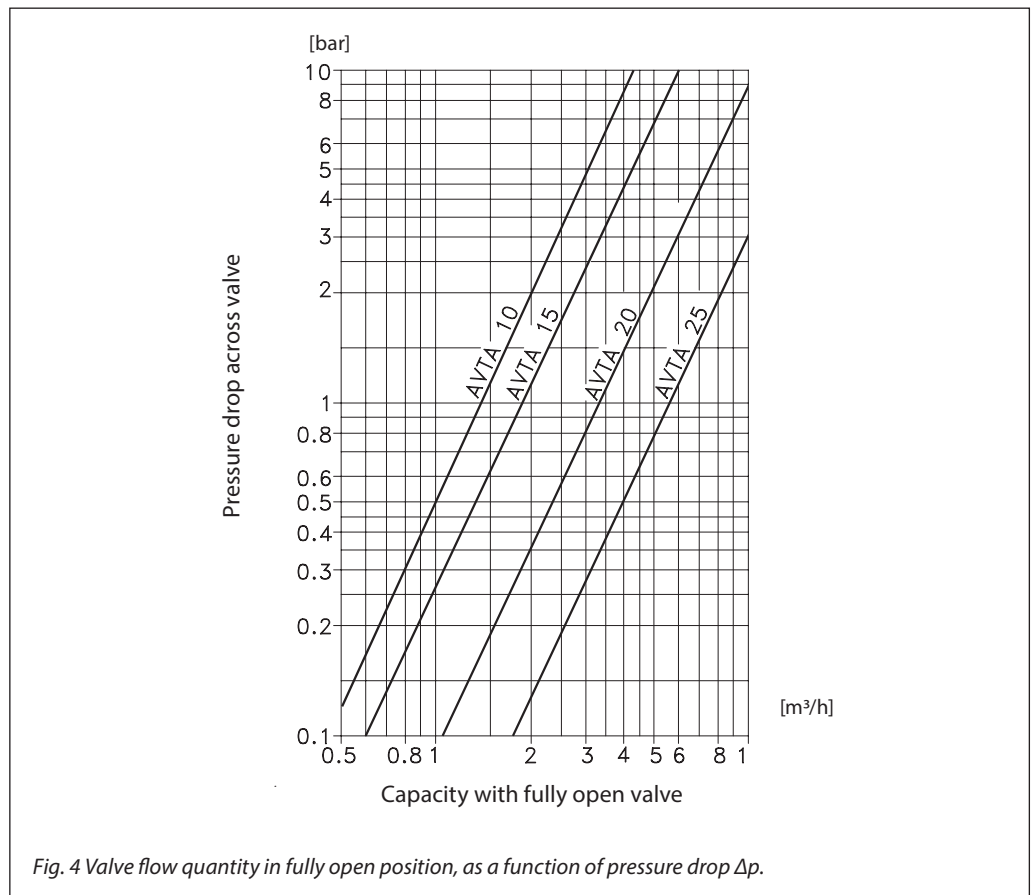

Options

- DZR brass
- Outer thread connecting
- Other lengths of capillary tubes
- Armouring of capillary tubes
- Other combinations of sizes, materials and ranges
- NPT – connection, see separate datasheet for USA / Canada

Danfoss can accept no responsibility for possible errors in catalogues, brochures and other printed material. Danfoss reserves the right to alter its products without notice. This also applies to products already on order provided that such alterations can be made without subsequential changes being necessary in specifications already agreed. All trademarks in this material are property of the respective companies. Danfoss and the Danfoss logotype are trademarks of Danfoss A/S. All rights reserved.