

# LK-S CO2 RS485 Modbus

Combined sensor CO<sub>2</sub> / temperature / rel. humidity

**thermokon**  
Sensortechnik GmbH

## Datasheet

Subject to technical alteration  
Issue date: 24.08.2015



## Application

Duct air quality sensor for combined detection of CO<sub>2</sub>, relative humidity and temperature. Designed for control and monitoring applications.

## Security Advice – Caution



The installation and assembly of electrical equipment should only be performed by authorized personnel.

The product should only be used for the intended application. Unauthorised modifications are prohibited! The product must not be used in relation with any equipment that in case of a failure may threaten, directly or indirectly, human health or life or result in danger to human beings, animals or assets. Ensure all power is disconnected before installing. Do not connect to live/operating equipment.

Please comply with

- Local laws, health & safety regulations, technical standards and regulations
- Condition of the device at the time of installation, to ensure safe installation
- This data sheet and installation manual

## Notes on Disposal



As a component of a large-scale fixed installation, Thermokon products are intended to be used permanently as part of a building or a structure at a pre-defined and dedicated location, hence the Waste Electrical and Electronic Act (WEEE) is not applicable. However, most of the products may contain valuable materials that should be recycled and not disposed of as domestic waste. Please note the relevant regulations for local disposal.

## Build-up of Self-Heating by Electrical Dissipative Power

Temperature sensors with electronic components always have a dissipative power, which affects the temperature measurement of the ambient air. The dissipation in active temperature sensors shows a linear increase with rising operating voltage. This dissipative power has to be considered when measuring temperature. In case of a fixed operating voltage ( $\pm 0,2$  V) this is normally done by adding or reducing a constant offset value. As Thermokon transducers work with a variable operating voltage, only one operating voltage can be taken into consideration, for reasons of production engineering. Transducers 0..10 V / 4..20 mA have a standard setting at an operating voltage of 24 V =. That means, that at this voltage, the expected measuring error of the output signal will be the least. For other operating voltages, the offset error will be increased by a changing power loss of the sensor electronics. If a re-calibration should become necessary later directly on the sensor, this can be done by means of a trimming potentiometer on the sensor board.

**Remark: Occurring draft leads to a better carrying-off of dissipative power at the sensor. Thus temporally limited fluctuations might occur upon temperature measurement.**

## Application Notice for Humidity Sensors

**Refrain from touching the sensitive humidity sensor/element. Touching the sensitive surface will void warranty.**

For standard environmental conditions re-calibration is recommended once a year to maintain the specified accuracy.

When exposed to high ambient temperature and/or high levels of humidity or presence of aggressive gases (i.e. chlorine, ozone, ammonia) the sensor element may be affected and re-calibration may be required sooner than specified. Re-calibration and deterioration of the humidity sensor due to environmental conditions are not subject of the general warranty.

## Information about Indoor Air Quality CO<sub>2</sub>

EN 13779 defines several classes for indoor air quality:

Category	CO <sub>2</sub> content above the content in outdoor air in ppm		Description
	Typical range	Standard value	
IDA1	<400 ppm	350 ppm	Good indoor air quality
IDA2	400.. 600 ppm	500 ppm	Standard indoor air quality
IDA3	600..1.000 ppm	800 ppm	Moderate indoor air quality
IDA4	>1.000 ppm	1.200 ppm	Poor indoor air quality

## Information about Self-Calibration Feature CO<sub>2</sub>

All gas sensors are subject to drift caused by components. This fact results generally in the need to recalibrate the sensors regularly.

With dual channel technology Thermokon integrates automatic self-calibration for different fields of operation. In contrast to common used ABC-Logic sensors with self-calibration dual channel are suitable for applications operating 24 hours, 7 days a week as for example hospitals.

**Manual calibration is not necessary!**

## Technical Data

Measuring values	temperature, humidity, CO2
Medium	air and non-aggressive gases
Network technology	RS485 Modbus, RTU or ASCII, half-duplex, baud rate 9.600, 19.200, 38.400 or 57.600, parity: non (2 stopbits), even or odd (1 stopbit)
Power supply	15..24 V = ( $\pm 10\%$ ) or 24 V ~ ( $\pm 10\%$ )
Power consumption	max. 3 W (24 V =   6 VA (24 V ~)
Measuring range temp	0..+50 °C
Measuring range humidity	0..100% rH
Measuring range CO2	0..2000 ppm
Accuracy temperature	$\pm 1\%$ of measuring range (typ. at 21 °C)
Accuracy humidity	$\pm 2\%$ between 10..90% rH (typ. at 21 °C)
Accuracy CO2	$\pm 75$ ppm or $\pm 10\%$ of measured value (typ. at 21 °C)
Air speed	min. 3 m/s, max. 10 m/s
Calibration	self-calibration Dual Channel
Sensor	NDIR (non-dispersiv, infrared)
Enclosure	PA6, pure white
Protection	IP65 according to EN 60529
Cable entry	M20 for wire max. $\varnothing=6$ mm
Connection electrical	terminal block, max. 1,5 mm <sup>2</sup>
Pipe	PA6, black, $\varnothing=19,5$ mm, length 180 mm
Filter	stainless steel wire mesh
Ambient condition	0..+50 °C, max. 85% rH non-condensing
Weight	450 g
Delivery content	MF20 TPO mounting flange
Notes	enclosure with connection wire (L=1,5 m)

## Mounting advices

The devices are supplied in a ready to use condition and are already equipped with a 1,5 m connection cable. Thus, there is no need to open the device. If an opening of the cover becomes necessary, however, please make sure that the housing will be hermetically-sealed, again.

The installation in a ventilation duct is made by means of the mounting flange included (fixing screws are not included).

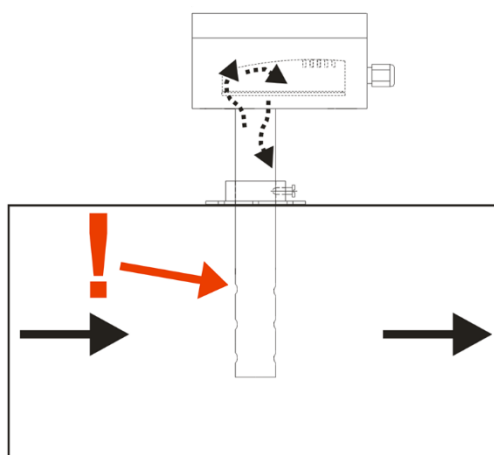

## Connection plan

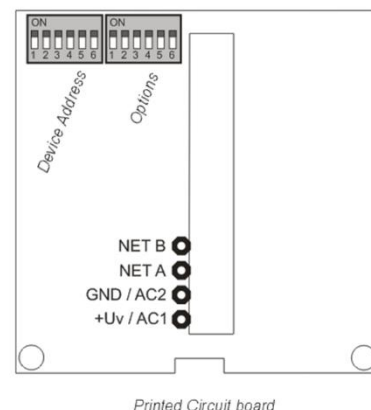
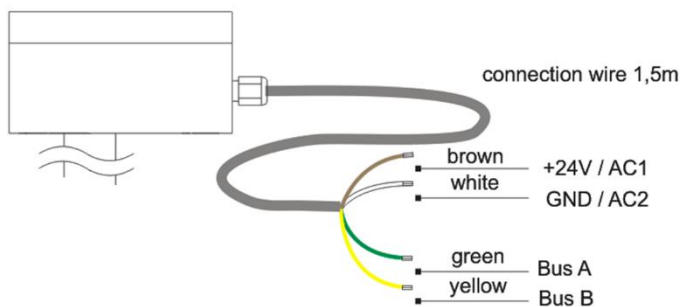

Device Address						Address
ON						0
ON	ON	ON	ON	ON	ON	1 default
ON	ON	ON	ON	ON	OFF	2
ON	ON	ON	ON	OFF	OFF	3
:	:	:	:	:	:	:
ON	ON	ON	ON	ON	ON	63

(binary coded)

Options					
ON					
ON	ON	ON	ON	ON	ON

1	Mode
off	RTU default
on	ASCII

2	3	Baud
off	off	9600 default
on	off	19200
off	on	38400
on	on	57600

4	5	Parity
on	off	even default
off	on	odd
off	off	no

6	Termination
off	inaktiv default
on	120Ohm

To set the dip switches according to the above illustration, the cover of the internal sensor housing has to be removed.

1. Remove the cover of the LK-S CO2, by removing the 4 screws on top of the housing and then remove the cover.
2. Now use a small screwdriver to unlock the cover of the internal sensor housing - see figure below.
3. Remove the cover of the internal sensor housing.

## Application notice

Dirt in the air can collect on the filter and then adversely affect the operation of the sensor after a certain time.

Under normal ambient condition an annual maintenance is recommended. Rinse the filter after cleaning with distilled water and dry it using clean oil-free air or nitrogen. Extremely contaminated filters should be replaced.

At extreme ambient conditions, e.g. corrosive gases, the humidity sensor may have to be changed.

## Dimensions (mm)

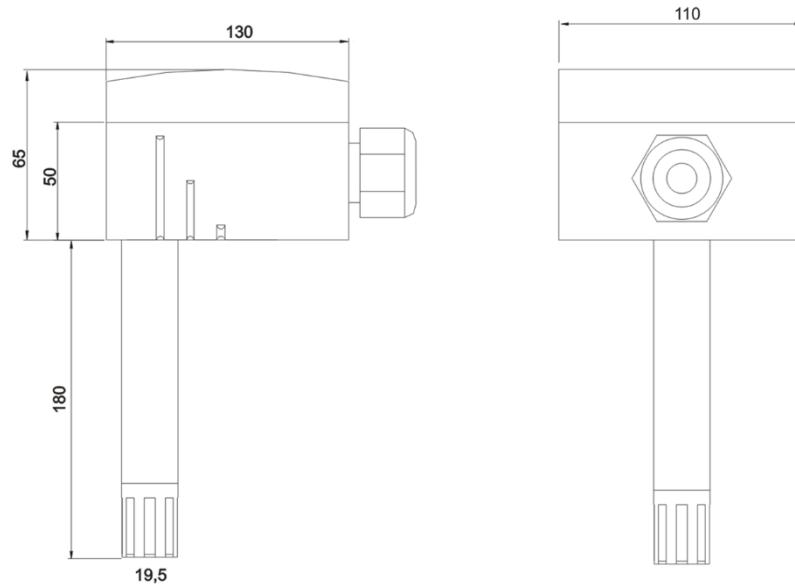

## Accessories

Rawl plugs and screws (2 pcs each)

Item No. 102209

Filter stainless steel, wire mesh

Item No. 231169

Mounting flange MF20 TPO

Item No. 612562