

Communicative globe valve actuator with emergency control function for 2-way and 3-way globe valves

- Actuating force 1000 N
- Nominal voltage AC/DC 24 V
- Control Modulating
- Nominal stroke 20 mm
- Design life SuperCaps: 15 years
- Communication via LONWORKS® (FTT-10A)
- Conversion of sensor signals
- Integrated temperature controller

Technical data

Electrical data	Nominal voltage	AC/DC 24 V
	Nominal voltage frequency	50/60 Hz
	Nominal voltage range	AC 19.2...28.8 V / DC 21.6...28.8 V
	Power consumption in operation	2.5 W
	Power consumption in rest position	1.5 W
	Power consumption for wire sizing	6 VA
	Connection supply / control	Cable 1 m, 6 x 0.75 mm ²
Data for LONWorks	Certified	According to LONMARK® 3.3
	Processor	Neuron 3150
	Transceiver	FTT-10A
	Functional Profile as per LONMARK®	Damper Actuator Object #8110 Open Loop Sensor Object #1 Thermostat Object #8060
	LNS plug-in for actuator / sensor / controller	Can be run with any LNS-based integration tool (Min. for LNS 3.x)
	Service button and status LED	According to LONMARK® guidelines
	Conductors, cables	Signal cable lengths, cable specifications and topology of the LONWORKS® network in accordance with the ECHELON® guidelines
Functional data	Actuating force motor	1000 N
	Position feedback U	DC 2...10 V
	Position feedback U note	Max. 0.5 mA
	Position feedback U variable	Start point DC 0.5...8 V End point DC 2.5...10 V
	Setting emergency setting position (POP)	Actuator spindle 0...100%, adjustable (POP rotary button)
	Bridging time (PF) variable	1...10 s
	Position accuracy	5% absolute
	Manual override	Gear disengagement with push-button
	Nominal stroke	20 mm
	Actuating time	150 s / 20 mm
	Actuating time variable	90...150 s / 20 mm
	Actuating time emergency control function	35 s / 20 mm
	Adaption setting range	manual (automatic on first power-up)
	Override control, controllable via nviManOvrd	MAX (maximum position) = 100% MIN (minimum position) = 0% ZS (intermediate position) = 50%
	Sound power level motor	45 dB(A)
	Sound power level emergency control position	60 dB(A)
	Position indication	Mechanically, 5...20 mm stroke
Safety	Protection class IEC/EN	III Safety extra-low voltage
	Degree of protection IEC/EN	IP54
	EMC	CE according to 2004/108/EC
	Certification IEC/EN	IEC/EN 60730-1 and IEC/EN 60730-2-14
	Mode of operation	Type 1.AA
	Rated impulse voltage supply / control	0.8 kV
	Control pollution degree	3

Technical data

Safety	Ambient temperature	0...50 °C
	Non-operating temperature	-40...80 °C
	Ambient humidity	95% r.h., non-condensing
	Maintenance	Maintenance-free
Weight	Weight approx.	1.7 kg
Terms	Abbreviations	POP = Power off position / emergency setting position CPO = Controlled power off / controlled emergency control function PF = Power fail delay time / bridging time

Safety notes



- This device has been designed for use in stationary heating, ventilation and air conditioning systems and must not be used outside the specified field of application, especially in aircraft or in any other airborne means of transport.
- Only authorised specialists may carry out installation. All applicable legal or institutional installation regulations must be complied during installation.
- The switch for changing the direction of motion and so the closing point may be adjusted only by authorised specialists. The direction of motion is critical, particularly in connection with frost protection circuits.
- The device may only be opened at the manufacturer's site. It does not contain any parts that can be replaced or repaired by the user.
- Cables must not be removed from the device.
- The device contains electrical and electronic components and must not be disposed of as household refuse. All locally valid regulations and requirements must be observed.

Product features

Principle of operation The actuator is equipped with an integrated interface for LONWORKS®. The actuator can be directly connected to the LON network and controlled via the transceiver FTT-10A
Interrupting the supply voltage causes the valve to be moved to the selected emergency setting position (POP) by means of stored electrical energy.

Product features

Pre-charging time (start up) The capacitor actuators require a pre-charging time. This time is used for charging the capacitors up to a usable voltage level. This ensures that, in the event of an electricity interruption, the actuator can move at any time from its current position into the preset emergency setting position (POP).

The duration of the pre-charging time depends mainly on following factors:

- Duration of the electricity interruption
- PF delay time (bridging time)

Typical pre-charging time

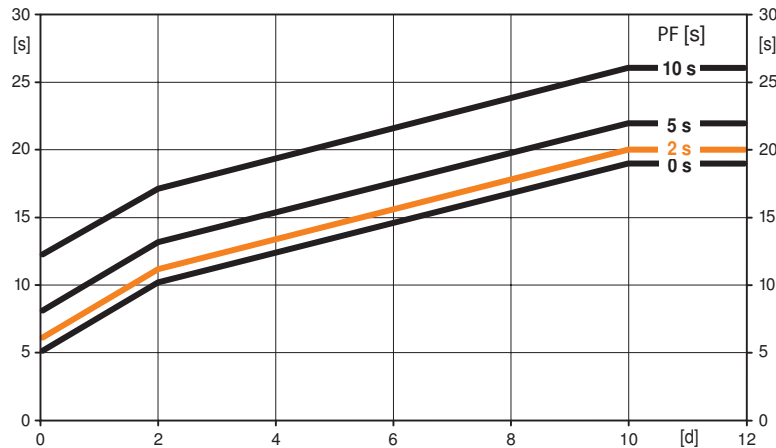

[d] = Electricity interruption in days
 [s] = Pre-charging time in seconds
 PF[s] = Bridging time

Calculation example: Given an electricity interruption of 3 days and a bridging time (PF) set at 5 s, the actuator requires a pre-charging time of 14 s after the electricity has been reconnected (see graphic).

PF [s]	[d]				
	0	1	2	7	≥10
0	5	8	10	15	19
2	6	9	11	16	20
5	8	11	13	18	22
10	12	15	17	22	26

Delivery condition (capacitors) The actuator is completely discharged after delivery from the factory, which is why the actuator requires approximately 20 s pre-charging time before initial commissioning in order to bring the capacitors up to the required voltage level.

Converter for sensors Connection option for a sensor (passive or active sensor or switching contact). In this way, the analogue sensor signal can be easily digitised and passed along to LONWORKS®.

Integrated temperature controller The device has an integrated temperature controller (Thermostat Object LONMARK® #8060). Other control variants upon request. The temperature controller can be set using the LNS Plug-In from Belimo.

Parameterisable actuators The factory settings cover the most common applications. Single parameters can be modified with the Belimo Service Tools MFT-P or ZTH EU.

Simple direct mounting Simple direct mounting on the globe valve by means of form-fit hollow clamping jaws. The actuator can be rotated by 360° on the valve neck.

Manual override Manual control with push-button possible - temporary. The gear is disengaged and the actuator decoupled for as long as the button is pressed. The stroke can be adjusted by using a hexagon socket screw key (4 mm), which is inserted into the top of the actuator. The stroke spindle extends when the key is rotated clockwise.

High functional reliability The actuator is overload protected, requires no limit switches and automatically stops when the end stop is reached.

Combination valve/actuator Refer to the valve documentation for suitable valves, their permitted medium temperatures and closing pressures.

Position indication The stroke is indicated mechanically on the bracket with tabs. The stroke range adjusts itself automatically during operation.

Product features

Home position	<p>Factory setting: Actuator spindle is retracted.</p> <p>When valve-actuator combinations are shipped, the direction of motion is set in accordance with the closing point of the valve.</p> <p>The first time the supply voltage is switched on, i.e. at the time of commissioning, the actuator carries out an adaption, which is when the operating range and position feedback adjust themselves to the mechanical setting range.</p> <p>The actuator then moves into the position defined by the positioning signal.</p>
Direction of rotation switch	<p>When actuated, the direction of stroke switch changes the running direction in normal operation. The direction of stroke switch has no influence on the emergency setting position (POP) which has been set.</p>
Adaption and synchronisation	<p>An adaption can be triggered manually by pressing the “Adaption” button or with the PC-Tool. Both mechanical end stops are detected during the adaption (entire setting range).</p> <p>Automatic synchronisation after pressing the gearbox disengagement button is configured. The synchronisation is in the home position (0%).</p> <p>The actuator then moves into the position defined by the positioning signal.</p> <p>A range of settings can be adapted using the PC-Tool (see MFT-P documentation)</p>
Emergency setting position (POP) rotary knob	<p>The rotary knob «Emergency setting position» can be used to adjust the desired emergency setting position (POP) between 0 and 100% in 10% increments. The rotary knob refers to the adapted or programmed height of stroke. In the event of an electricity interruption, the actuator will move into the selected emergency setting position (POP), taking into account the bridging time (PF) of 2 s which was set ex-works.</p> <p>Settings: The rotary knob must be set to the «Tool» position for retroactive settings of the emergency setting position (POP) with the Belimo service tool MFT-P. Once the rotary knob is set back to the range 0...100%, the manually set value will have positioning authority.</p>
Bridging time	<p>Electricity interruptions can be bridged up to a maximum of 10 s.</p> <p>In the event of an electricity interruption, the actuator will remain stationary in accordance with the set bridging time. If the electricity interruption is greater than the set bridging time, then the actuator will move into the selected emergency setting position (POP).</p> <p>The bridging time set ex-works is 2 s. This can be modified on site in operation with the use of the Belimo service tool MFT-P.</p> <p>Settings: The rotary knob must not be set to the «Tool» position! Only the values need to be entered for retroactive adjustments of the bridging time with the Belimo service tool MFT-P.</p>

Accessories

	Description	Type
Electrical accessories	Connecting cable 5 m, A+B: RJ12 6/6, To ZTH/ZIP-USB-MP	ZK1-GEN
	Connection cable 5 m, A: RJ11 6/4, B: Free wire end, To ZTH/ZIP-USB-MP	ZK2-GEN
	Description	Type
Service Tools	Service Tool, for MF/MP/Modbus/LonWorks actuators and VAV-Controller	ZTH EU
	Belimo PC-Tool, software for adjustments and diagnostics	MFT-P
	Adapter to Service-Tool ZTH	MFT-C

Electrical installation

	<p>Notes</p> <ul style="list-style-type: none"> • Connection via safety isolating transformer. • Direction of stroke switch factory setting: Actuator spindle retracted.
--	---

Electrical installation

Wiring diagrams

Connection without sensor

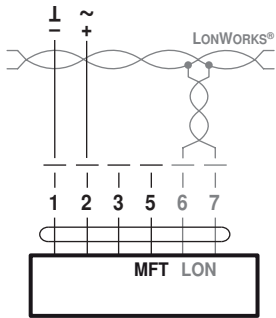

Connection with passive sensor, e.g. Pt1000, Ni1000, NTC

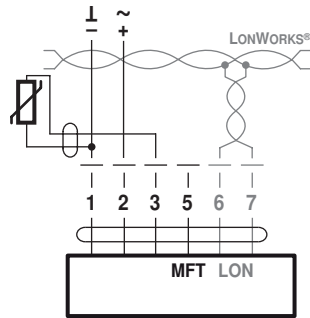

Ni1000	-28...+98 °C	850...1600 Ω ²⁾
PT1000	-35...+155 °C	850...1600 Ω ²⁾
NTC	-10...+160 °C ¹⁾	200 Ω...60 kΩ ²⁾

Sensor scaling:
The sensors can be scaled with the sensor plug-in (sensor table).
1) Depending on type
2) Resolution 1 Ohm

Connection with active sensor, e.g. 0...10 V @ 0...50 °C

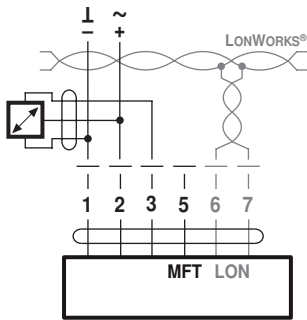

Possible voltage range:
0...32V (Resolution 30 mV)
Sensor scaling:
The sensors can be scaled with the sensor plug-in (sensor table)

Connection with switching contact, e.g. Δp monitor

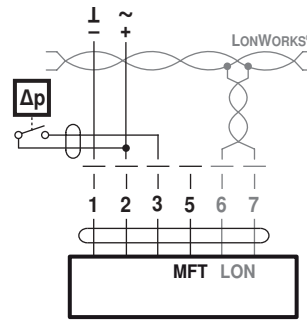

Switching contact requirements:
The switching contact must be able to switch a current of 16 mA at 24 V accurately.

Functional Profile as per LONMARK®

The LON-capable actuator is certified by LONMARK®. Die following actuator functions are made available via the LONWORKS® network as standardised network variables in accordance with LONMARK®: the Node Object #0, the Damper Actuator Object #8110, the Open Loop Sensor Object #1 and the Thermostat Object #8060.

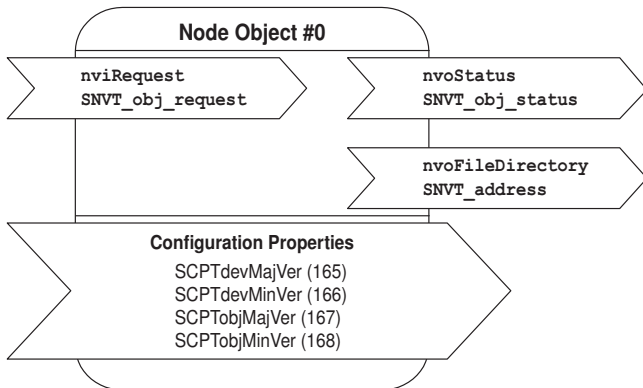

Node Object #0

The node object contains the object status and object request functions.

nviRequest: SNVT_obj_request

Input variable for requesting the status of a particular object in the node.

nvoStatus: SNVT_obj_status

Output variable that outputs the current status of a particular object in the node.

nvoFileDirectory: SNVT_address

Output variable that shows information in the address range of the Neuron chip.

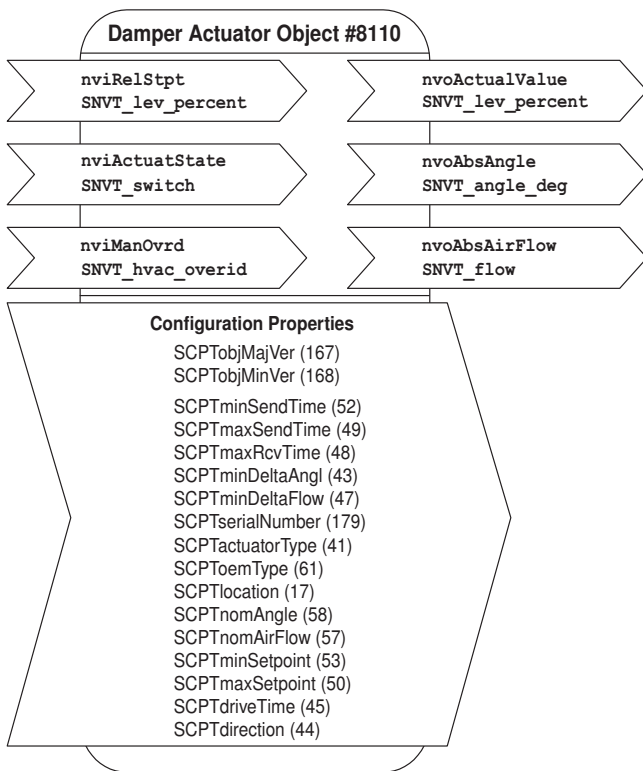

Damper Actuator Object #8110

The actuator object is used to display the functions of the actuator on the page of the LONWORKS® network.

nviRelStpt: SNVT_lev_percent

Via this input variable, the setpoint in % for the actuator is specified (0...100% = Min...Max). This variable is normally linked to the output variable of an HVAC controller.

nviActuateState: SNVT_switch

A preset position is assigned to the actuator via this input variable. Note on priority: The variable which was most recently active, either nviActuatorState or nviRelStpt, has priority.

nviManOvrd: SNVT_hvac_overid

see table «Override control with SNVT nviManOvrd»

nvoActualValue: SNVT_lev_percent

This output variable shows the current actual position of the actuator and can be used for control circuit feedback or for displaying positions.

nvoAbsAngle: SNVT_angle_deg

This output variable shows the current angle of rotation of the actuator and can be used to display the position or for service purposes.

nvoAbsAirFlow: SNVT_flow

This output variable is inactive with this actuator and shows a constant value of 65535 (this variable is only active in conjunction with LON-capable VAV controllers).

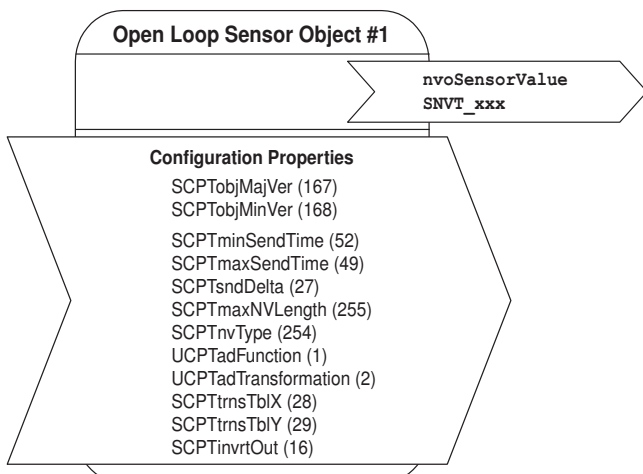

Open Loop Sensor Object #1

One sensor can be connected to the actuator.

A passive resistance sensor (e.g. Ni1000), an active sensor (output 0 ... 32 V) or a switch (On/Off) can be connected. In the case of the open loop sensor object, the measured sensor values are transferred to the LONWORKS® network.

nvoSensorValue: SNVT_XXX

This output variable shows the current sensor value. Depending on the connected sensor, the output variable can be configured via the sensor plug-in and specifically adapted to the system.

The SNVT .. can be configured as:

SNVT_temp_p	SNVT_lev_percent	SNVT_lux
SNVT_temp	SNVT_abs_humid	SNVT_press_p
SNVT_switch	SNVT_enthalpy	SNVT_smo_obscur
SNVT_flow	SNVT_ppm	SNVT_power
SNVT_flow_p	SNVT_rpm	SNVT_elec_kwh

Functional Profile as per LONMARK®

Individual room control solutions can be implemented with the thermostat object LONMARK® #8060. An LNS plug-in is available for configuring the controller parameters.

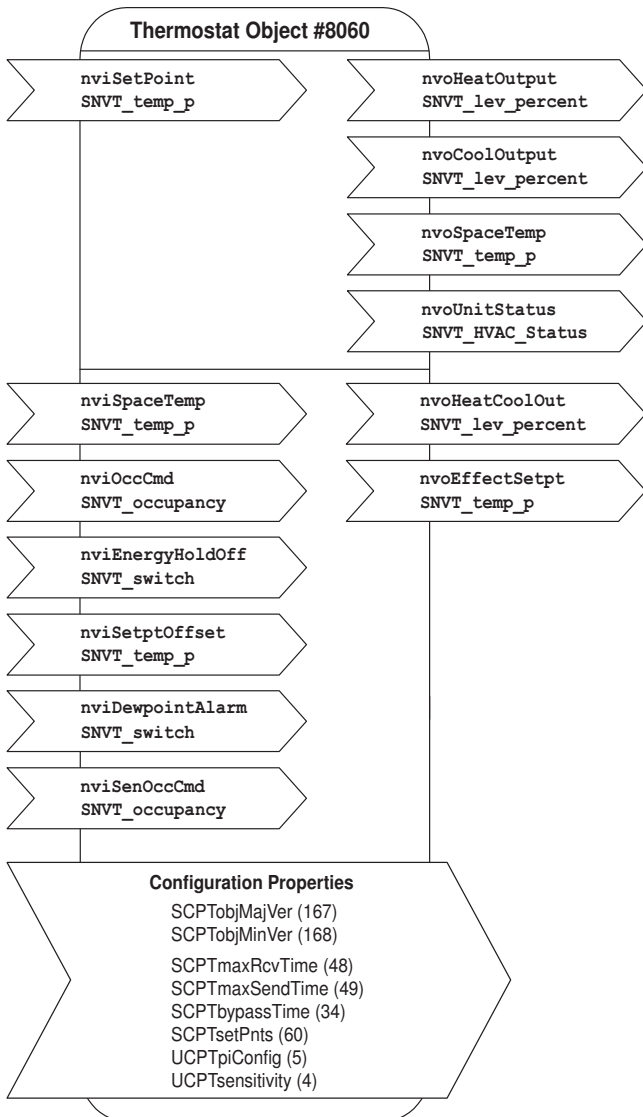

Thermostat Object #8060

nviSetPoint: SNVT_temp_p

Setpoint specification for the controller from the higher-level system or the room control unit. If this variable is not linked, then the local setpoints of the controller object apply (can be adjusted via plug-in).

The setpoint specification from the higher-level system influences the setting on the controller as follows:

Example: Comfort setpoint for heating = 21 °C and Comfort setpoint for cooling = 23 °C. The median point between heating and cooling is thus 22 °C. Now, if the external setpoint (nviSetPoint) is 23 °C, then the heating setpoint will shift to 22 °C and the cooling set point to 24 °C. The setpoints for Pre-Comfort heating and cooling will also be shifted accordingly.

nviSpaceTemp: SNVT_temp_p

Room temperature from external room sensor. It is imperative that this variable be linked; typically, it is linked with the variable of the sensor object.

nviOccCmd: SNVT_occupancy

Occupancy specification from the command centre (for the function, see the table entitled «Functions Inputs Occupancy» page 5).

nviEnergyHoldOff: SNVT_switch

In the case of active EnergyHoldOff, the controller will be set to the Building Protection setpoints.

nviSetPtOffset: SNVT_temp_p

Shifting of the room control unit. If the nviSetPoint is linked, then this input has an influence on the variable value of nviSetPoint, i.e. it corrects it. Otherwise, the Comfort and Pre-Comfort setpoints for heating and cooling will be adjusted directly by the amount of the shift (compare example with nviSetPoint).

nviDewpointAlarm: SNVT_switch

In the case of active DewpointAlarm, the controller will be set to the Building Protection setpoints. The cooling sequence is deactivated.

nviSenOccCmd: SNVT_occupancy

Occupancy specification from the local occupancy switch (for the function, see the table entitled «Functions Inputs Occupancy» page 5).

nvoHeatOutput: SNVT_lev_percent

Control signal for heating.

nvoCoolOutput: SNVT_lev_percent

Control signal for cooling.

nvoSpaceTemp: SNVT_temp_p

Displays the room temperature of the nviSpaceTemp. If nviSpaceTemp is not linked, then the variable will display the value 0x7FFF.

nvoUnitStatus: SNVT_HVAC_Status

Displays the operating mode of the controller (in accordance with Functional Profile #8060).

nvoHeatCoolOut: SNVT_lev_percent

Depicts the heating and cooling sequence for controlling the 6-way characterised control valves (see illustration, page 5).

This outlet runs parallel to the nvoCoolOutput or the nvoHeatOutput, respectively.

Cooling = 33 ... 0%

Valve closed 33 ... 66%

Heating = 66 ... 100%

nvoEffectSetpt: SNVT_temp_p

Shows the actual setpoint of the controller.

Note

A restart is necessary after accessing network variables for the purpose of rewriting them or after deleting links in order to initialise the variables.

Operating controls and indicators

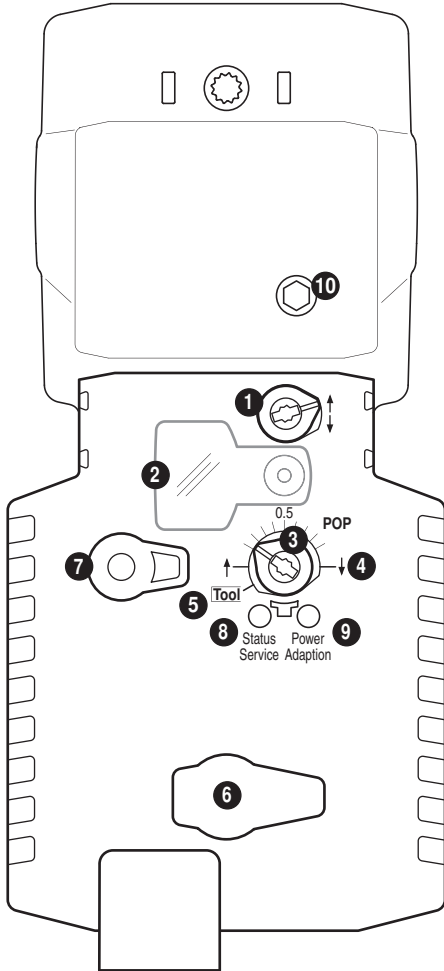

- 1 Direction of stroke switch**
Switch over: Direction of stroke changes
- 2 Cover, POP button**
- 3 POP button**
- 4 Scale for manual adjustment**
- 5 Position for adjustment with tool**
- 6 Service plug**
For connecting the parameterisation and service tools
- 7 Gear disengagement button**
Press button: Gear disengaged, motor stops, manual override possible
Release button: Gear engaged, standard mode

LED displays		Meaning / function
8 yellow	9 green	
Off	On	The actuator is linked to the LONWORKS® and ready for operation
Off	Flashing	POP functions active
On	Off	Pre-charging time SuperCap, fault SuperCap or wiring error in supply
Off	Off	Not in operation
On	On	No application software is loaded in the actuator
Flashing	On	The actuator is ready for operation, but not linked to the LONWORKS® (unconfigured)

- 8 Service button for commissioning at LONWORKS® (LED yellow)**
Press button: Service Pin Message is sent to LONWORKS®
- 9 Push-button (LED green)**
Press button: Triggers stroke adaptation, followed by standard mode
- 10 Manual override**
Clockwise: Actuator spindle extends
Counterclockwise: Actuator spindle retracts

Setting emergency setting position (POP)

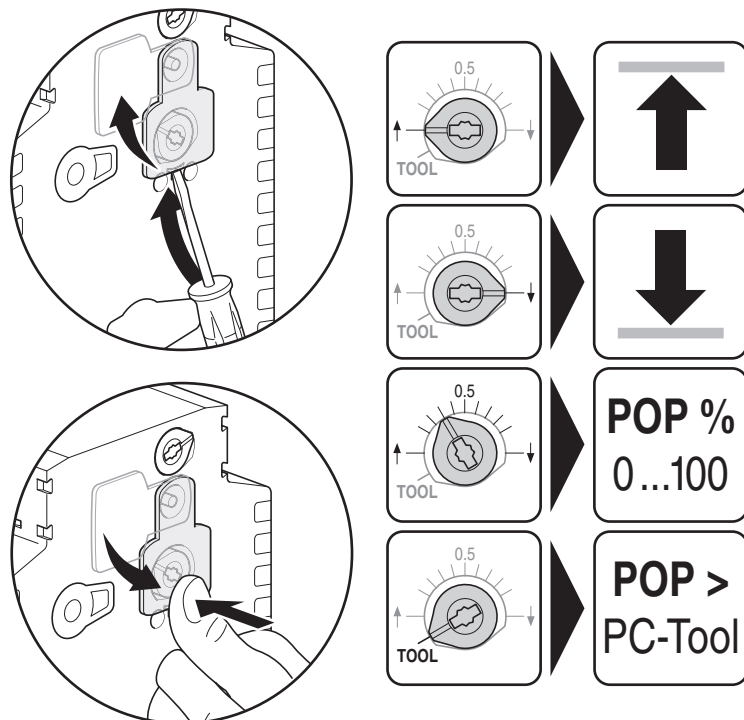

Service



Notes

- The actuator can be parameterised by PC-Tool and ZTH EU via the service socket.

ZTH EU connection

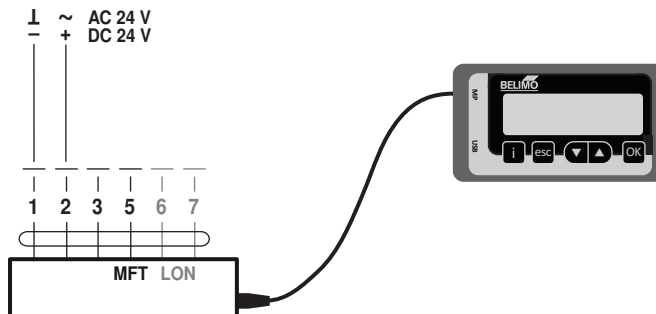

PC-Tool connection

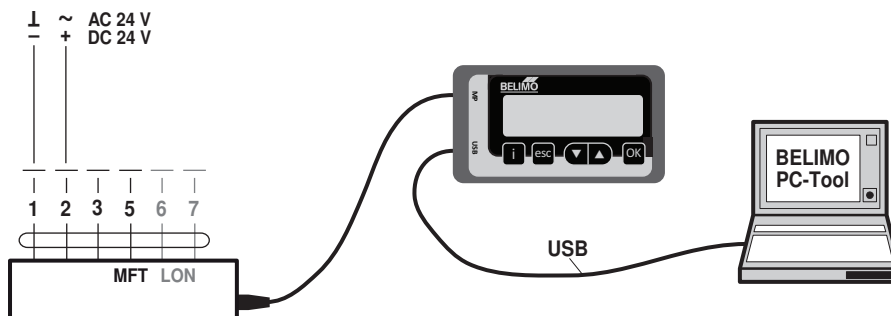

Dimensions [mm]

Dimensional drawings

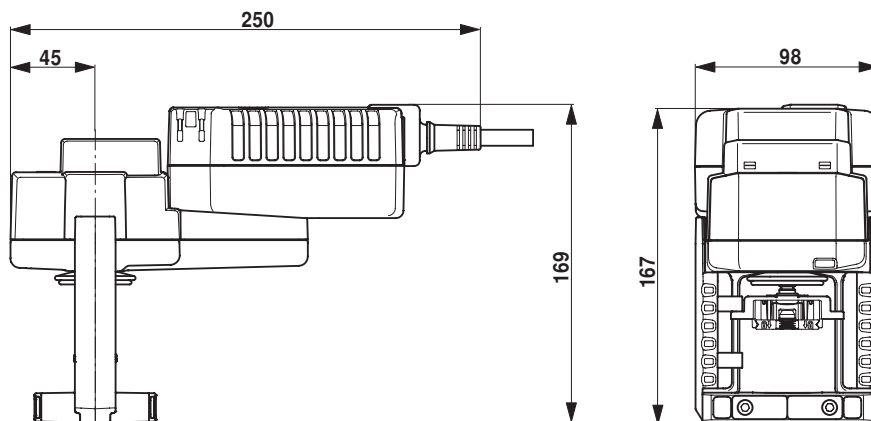

Further documentation

- Applications with integrated temp. controller
- LON actuators with CO₂ control
- Actuator Plug-in description
- Sensor Plug-in description
- Controller Plug-in description
- Tool connections
- LonWorks® Glossary