



RC-C30

Pre-programmed room controller with communication and forced ventilation

RC-C30 is a complete pre-programmed room controller from the Regio Midi series intended to control heating and cooling in a zone control system.

RC-C30 is a room controller in the Regio series. It has communication via RS485 (Modbus or EXOline) for systems integration.

Regio

Regio is an extensive range of controllers for control of heating and cooling.

The controllers are divided into three different series; Mini, Midi and Maxi. Mini consists of pre-programmed, stand-alone controllers. Maxi consists of freely programmable controllers with communication. The Midi controllers, of which RC-C30 is a part, consists of pre-programmed controllers with communication.

Applications

The Regio controllers are suitable for use in buildings requiring optimum comfort and reduced energy consumption, such as offices, schools, shopping centres, airports, hotels and hospitals etc.

See application examples on page 4.

Sensor

The controller has a built-in room temperature sensor. An external sensor for room temperature, change-over or supply air temperature limitation can also be connected (PT1000).

Actuators

RC-C30 can control 0...10 V DC valve actuators and/or 24 V AC thermal actuators or On/Off actuators with spring return.

Flexibility with communication

RC-C30 can be connected to a central SCADA system via RS485 (EXOline or Modbus) and configured for a specific application using the free configuration software Regio tool[®]. Read more about Regio tool[®] on page 3.



Short facts about RC-C30

- Communication via RS485 (Modbus or EXOline)
- Quick and simple configuration via Regio tool[®]
- Easy installation
- On/Off or 0...10 V control
- Input for occupancy detector, window contact, condensation sensor or change-over function
- Supply air temperature limitation

Easy to install

The modular design, featuring a separate bottom plate for wiring, makes the entire Regio range of controllers easy to install and commission. The bottom plate can be put into place before the electronics are installed. Mounting takes place directly on the wall or on an electrical connection box.



THE CHALLENGER IN BUILDING AUTOMATION

Control modes

RC-C30 can be configured for different control modes/control sequences:

- Heating
- Heating/Heating
- Heating/Cooling via change-over
- Heating/Cooling
- Heating/Cooling with VAV-control and forced supply air function
- Heating/Cooling with VAV-control
- Cooling
- Cooling/Cooling
- Heating/Cooling/VAV
- Change-over with VAV function

Operating modes

There are five different operating modes: Off, Unoccupied, Stand-by, Occupied and Bypass. Occupied is the preset operating mode. It can be set to Stand-by via a DIP switch. The operating modes can be activated via a central command, an occupancy detector or the Occupancy button.

Off: Heating and cooling are disconnected. However, frost protection is still active (factory setting (FS))=8°C). This mode is activated if a window is opened.

Unoccupied: The room in which the controller is placed is not used for an extended time period, such as during holidays or long weekends. Both heating and cooling are kept within a temperature interval with configurable min/max temperatures (FS min=15°C, max=30°C).

Stand-by: The room is in an energy saving mode and is not used at the moment. This can, for instance, be during nights, weekends and evenings. The controller stands by to change operating mode to Occupied if presence is detected. Both heating and cooling are kept within a temperature interval with configurable min/max temperatures (FS min=15°C, max=30°C).

Occupied: The room is in use and a comfort mode is activated. The controller maintains the temperature around a heating setpoint (FS=22°C) and a cooling setpoint (FS=24°C).

Bypass: The temperature in the room is controlled in the same way as in the Occupied operating mode. The output for forced ventilation is also active. This operating mode is useful for instance in conference rooms, where many people are present at the same time for a certain period of time.

When Bypass has been activated by pressing the occupancy button, the controller will automatically return to its preset operating mode (Occupied or Stand-by) after a configurable time has elapsed (FS=2 hours). If an occupancy detector is used, the controller will automatically return to its preset operating mode if no occupancy is detected for 10 minutes.

Occupancy detector

By connecting an occupancy detector, RC-C30 can switch between the preset operating mode for presence (Bypass or Occupied) and its preset operating mode. This way, the temperature is controlled from requirement, making it possible to save energy while maintaining the temperature at a comfortable level.

The occupancy button

Pressing the occupancy button for less than 5 seconds when the controller is in its preset operating mode will cause it to change to operating mode Bypass. Pressing the button for less than 5 seconds when the controller is in Bypass mode will change its operating mode to the preset operating mode.

If the occupancy button is depressed for more than 5 seconds will change the controller's operating mode to "Shutdown" (Off/Unoccupied) regardless of its current operating mode. Regio tool® enables selecting which operating mode, Off or Unoccupied, should be activated on "Shutdown" (FS=Unoccupied). Pressing the button for less than 5 seconds when the controller is in Shutdown mode will cause it to revert to Bypass mode.



Forced ventilation

Regio has a built-in function for forced ventilation. If the occupancy operating mode has been configured for this function, a closing of the digital occupancy detector input will set the controller to Bypass mode and activate the output for forced ventilation (UO3). This can for instance be used to open a damper. The function is terminated when the settable forcing interval has run out.

Change-over function

RC-C30 has an input for change-over that automatically resets output UO1 to operate with heating or cooling function. The input can be connected to sensors of type PT1000, with the sensor mounted so that it senses the temperature of the coil supply pipe. As long as the heating valve is more than 20 % open, or each time a valve exercise takes place, the difference between the media and room temperature is calculated. The control mode is then changed based on the temperature difference.

Optionally, a potential-free contact can be used. When the contact is open, the controller will operate using the heating function, and when closed using the cooling function.

Setpoint adjustment

When in mode Occupied, the controller operates using a heating setpoint (FS=22°C) or a cooling setpoint (FS=24°C) that can be changed centrally or locally using DIP switches.

Setpoint can be adjusted up and down (FS=±3°C) using the knob on the front of the controller. Switching between heating and cooling setpoints takes place automatically in the controller depending on heating or cooling requirements.

Built-in safety functions

RC-C30 has an input for a condensation sensor to detect moisture accumulation. If detected, the cooling circuit will be stopped. The controller also has frost protection. This prevents frost damages by ensuring that the room temperature does not drop below 8°C when the controller is in mode Off.

Indication

The controller has a LED shaped as a thermometer on its front. A red light indicates heating control is active and a blue light indicates active cooling control. If the LED is switched off, it means neither heating or cooling control is active.



Supply air temperature limitation

All can be configured for use with a supply air temperature limitation sensor. A room controller will then work together with a supply air temperature controller using cascade control, resulting in a calculated supply air temperature maintaining the room temperature setpoint. It is possible to set individual min/max limitation setpoints for heating and cooling. Settable temperature range: 10...50°C.

Lighting control

UO3 can be set to control lighting. When occupancy is detected, lighting is activated, remaining switched on for as long as someone is in the room. The Standby/ Occupied/Bypass operating modes are active as usual. If the controller is in Off-mode (Off/Unoccupied), the occupancy input will be active if UO3 is configured for lighting control.

Actuator exercise

All actuators are exercised, regardless of type or model. The exercise takes place at intervals, settable in hours (FS=23 hours interval). An opening signal is sent to the actuator for as long time as its configured run time. A closing signal is then sent for an equal amount of time, after which the exercise is completed. Actuator exercise is switched off if the interval is set to 0.

EC fan control

Control of an EC fan can be set using Regio tool®. It is possible to select whether the fan should run in Heating, Cooling or both Heating and Cooling.

Fan boost function

If there is a great difference between the room setpoint and the current room temperature, or if one simply wishes to hear the fan start, a boost function can be activated to make the fan run at top speed for a short start-up duration.

Fan kickstart

When using today's energy-saving EC fans, there is always a risk the fan will not start due to the low control voltage preventing the fan from exceeding its starting torque. The fan will then remain at a standstill while power still flows through it, which may give rise to damage. To prevent this, a fan kickstart function can be activated. The fan output will then be set to 100 % for a set time (1...10 s) when the fan is set to run at its lowest speed when starting from an off position. In this way, the starting torque is exceeded. After the set time has elapsed, the fan will return to its original speed.

Configuration and supervision using Regio tool®

RC-C30 is pre-programmed upon delivery, but can be configured using Regio tool®.

Regio tool® is a PC-based program that makes it possible to configure and supervise an installation and change its settings using a comprehensive user interface.

The program can be downloaded free of charge from Regin's website www.regincontrols.com.

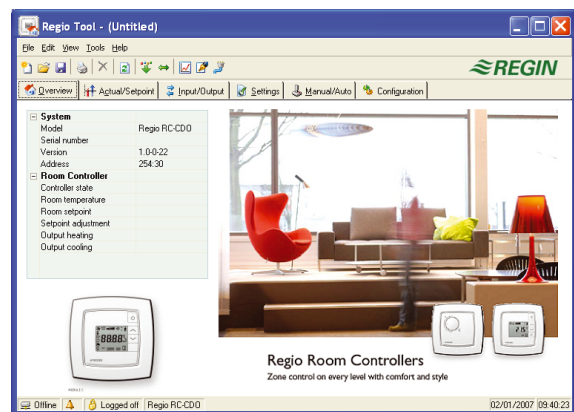

Application examples

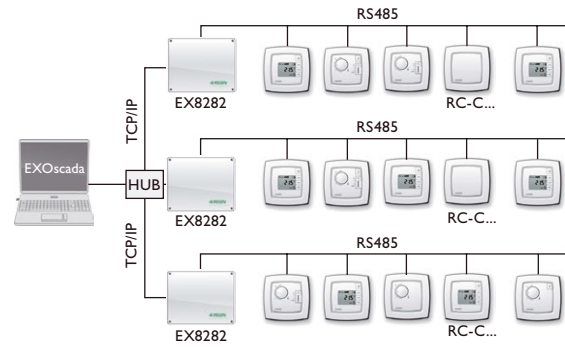
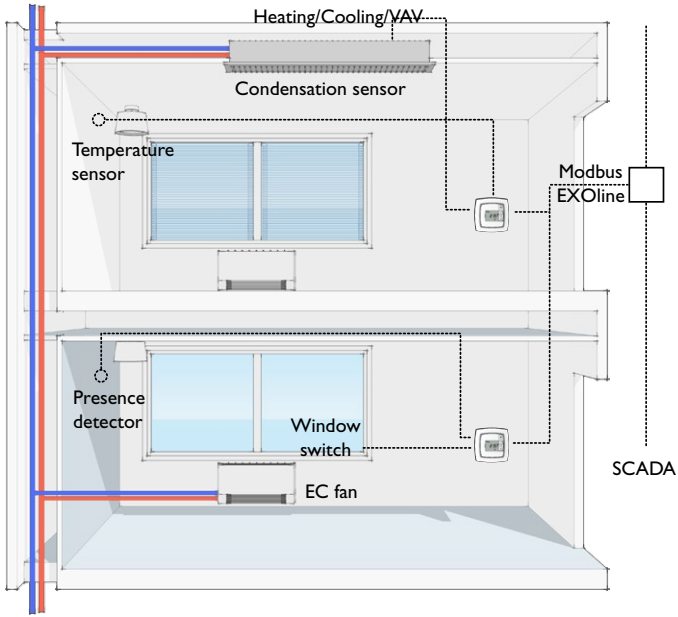

Technical data

Supply voltage	18...30 V AC, 50...60 Hz
Internal consumption	2.5 VA
Ambient temperature	0...50°C
Storage temperature	-20...+70°C
Ambient humidity	Max 90 % RH
Protection class	IP20
Communication	RS485 (EXOline or Modbus) with automatic detection/change-over
Modbus	8 bits, 1 or 2 stop bits. Odd, even (FS) or no parity.
Communication speed	9600, 19200 or 38400 bps (changeable)
Built-in temperature sensor	NTC type, measuring range 0...50°C, accuracy $\pm 0.5^\circ\text{C}$ at 15...30°C
Material, casing	Polycarbonate, PC
Weight	110g
Colour	Cover: Polar white RAL9010 Bottom plate: Light gray



Is available in other colours on inquiry, contact Regin for more information

EMC emissions & immunity standards: This product confirms to the requirements of the EMC Directive 2004/108/EC through product standards EN 61000-6-1 and EN 61000-6-3.

RoHS: This product conforms with the Directive 2011/65/EU of the European Parliament and of the Council.

Inputs

External room sensor or supply air temperature limitation sensor	PT1000 sensor, 0...50°C. Suitable sensors are Regin's TG-R5/PT1000, TG-UH/PT1000 and TG-A1/PT1000.
Change-over alt. potential-free contact	PT1000 sensor, 0...100°C. Suitable sensor is Regin's TG-A1/PT1000.
Occupancy detector	Closing potential-free contact. Suitable occupancy detector is Regin's IR24-P.
Condensation sensor, window contact	Regin's condensation sensor KG-A/1 resp. potential-free contact

Outputs

Valve actuator, thermal actuator (On/Off pulsing) or On/Off actuator (UO1, UO2)	2 outputs 0...10 V, max. 5 mA 24 V AC, max. 2.0 A (time-proportional pulse output signal) 24 V AC, max. 2.0 A Heating, Cooling or VAV (damper)
Damper actuator, EC fan or lighting control (UO3)	1 output 24 V AC, max. 2.0 A, alt. 0...10 V, max. 5 mA Forced ventilation, alt. EC fan or damper following Heating/Cooling in sequence alt. lighting control (on/off)

Setpoint settings via Regio tool®

Basic heating setpoint	5...40°C
Basic cooling setpoint	5...50°C
Setpoint displacement	$\pm 0...10^\circ\text{C}$ (FI= $\pm 3^\circ\text{C}$)

Basic heating setpoint, set via DIP switches

The ON-position is marked on the DIP switch. The cooling setpoint is 2°C higher.

Basic setpoint, heating (°C)	SW1	SW2
20	OFF	OFF
22 (FS)	OFF	ON
24	ON	OFF
26	ON	ON

Other DIP switches

	ON	OFF	Comment
SW3	Stand-by	Occupied (FS)	Preset operating mode
SW4	DI, window switch. Closed contact indicates closed window.	CI, Regin's condensation sensor, KG-A/1 (FS)	Function terminal 33, DI2/CI.
SW5	Digital output for 24 V AC thermal actuator.	Analogue output for 0...10 V DC valve actuator (FS).	Function terminal 23, UO1.
SW6	Digital output for 24 V AC thermal actuator.	Analogue output for 0...10 V DC valve actuator (FS).	Function terminal 24, UO2.
SW7	External, PT1000-sensor	Internal NTC-sensor (FS)	Temperature sensor
SW8	NO	NC (FS)	Function terminal 23, UO1
	<p>Selecting NC (factory setting) in the controller gives direct action on output UO1, i.e. increasing output signal (longer pulses) on increasing controller output. This setting is used when UO1 is connected to a thermal actuator of type Regin RTAM-24 (NC). In the event of system power outage, the valve will close.</p> <p>Selecting NO in the controller will give output UO1 the opposite effect, providing a decreasing output signal (shorter pulses) on increasing controller output. This setting is used when UO1 is connected to a thermal actuator of type Regin RTAM-24 (NO) on UO1. In the event of system power outage, the valve will open.</p>		

Wiring

Terminal	Designation	Function
10	G	Supply voltage 24 V AC
11	G0	Supply voltage 0 V
12-14		No function
20	GDO	24 V AC out common for DO.
21	G0	0 V common for UO (if using 0...10 V actuators)
22	UO3	Damper output for forced ventilation (24 V AC), alt. EC fan following output for heating/cooling, alt. damper following cooling in sequence, alt. lighting control (on/off)
23	UO1	Output for 0...10 V valve actuator alt. thermal or On/Off actuator. Heating (FS), Cooling or Heating/Cooling via change-over.
24	UO2	Output for 0...10 V valve actuator alt. thermal or On/Off actuator. Heating or cooling (FS).
30	AI1	Input for an external sensor, alt. supply air temperature limitation sensor
31	UI1	Input for change-over sensor, alt. potential-free contact
32	DI1	Input for occupancy detector, alt. window contact
33	DI2/CI	Input for Regin's condensation sensor KG-A/1 alt. window switch
40	+C	24 V DC out common for UI and DI
41	AGnd	Analogue ground
42	A	RS485-communication A
43	B	RS485 communication B

Dimensions

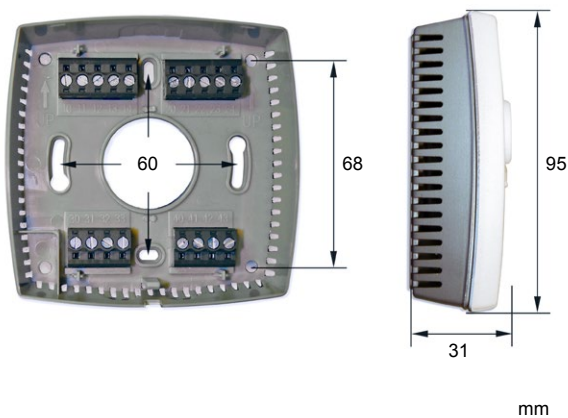

Product documentation

Document	Type
Regio Midi manual	Manual for the controllers from the Regio Midi series
Installation instruction Regio RC-C30	Installation instruction for Regio RC-C30
Product sheet TG-R4/PT1000, TG-R5/PT...	Information on suitable sensors for RC-C30
Product sheet TG-UH/PT...	
Product sheet TG-A1/PT...	
Product sheet IR24-P	Information on suitable occupancy detectors for RC-C30
Instruction IR24-P	
Product sheet KG-A/1	Information about condensation sensors for the Regio controllers

The documents can be downloaded from www.regincontrols.com.

Head Office Sweden

Phone: +46 31 720 02 00

Web: www.regincontrols.com

Mail: info@regin.se

REGIN

THE CHALLENGER IN BUILDING AUTOMATION